

Messrs.

(first · revised)

Delivery Specifications

Product No : Quartz Crystal Unit VT-200-F

Item code :

Product form : 32.768kHz $\pm 20 \times 10^{-6}$ / 6.0pF

The number of copies : 1 copy

Date of Registrantion :

Receipt Column	Note

〈NOTICE〉

1. Advance agreement will be needed before changing any contents of the specification herein.
2. Provided that the information herein is subject to change, only revised pages shall be reissued.
3. When the product described herein includes Regulated Products subject The Wassenaar Arrangement etc, they may not be exported without authorization form the appropriate governmental authorities.
4. The contents of this specification including all figures and illustrations are proprietary information (copyright or know-how) of Seiko Instruments Inc. It is strictly prohibited to copy all or part of these specifications to third parties without permission.
5. In the case that the products described herein are used as part of any devices or equipment which might influence any one of the human body, human life and property, such as physical exercise equipment, medical equipment or vehicles, please let us know that.

Seiko Instruments Inc.
 Quartz Crystal Division
 Network Components Business

1-8, Nakase, Mihamaku, Chiba shi,
 Chiba 261-8507 Japan

Dept. of Issue

Sales Section

Dept. of Control

Quality Assurance Section

1.Scope

These specifications apply to QUARTZ CRYSTAL RESONATORS (hereinafter referred to as RESONATORS) to be manufactured by Seiko Instruments Inc. (hereinafter referred to as SII) to _____

2.Designation

RESONATORS are designated " VT-200-F "(32.768kHz).

3.Shape and dimensions

As per the VT-200-F drawing shown on page 5 .

4.Electrical characteristics

Specified on page 2 through 3.

5.Shipment and packaging

- 5.1 (10,000) pcs are the standard lot size to which the lot number shall be allotted
- 5.2 The packaging shall conform to the resonator packaging standards.

6.Outgoing inspection

- 6.1 When mutually agreed, the outgoing inspection shall be conducted as per the standard on page 4.
- 6.2 The outgoing inspection slip is not basically affixed to each packaging.

7.Warranty

In the event that any defective RESONATORS or defective lot is found at incoming inspection at _____ and that any defect resulting from failure resin process-control at SII after incoming inspection is found, good RESONATORS shall be supplied to _____ free of charge as a replacement .

In the event that any trouble or problems arising directly from RESONATORS occurs, it will be amicably settled between both parties, provided that warranty shall be done within the scope of replacement of good RESONATORS.

8.Amendment or abolition of the specifications.

Amendment or abolition of the specifications shall be made upon mutual consent between _____ and SII .If any problem arises , it shall be amicably settled between both parties.

9.Effectiveness of the specifications

These specifications are effective after receipt of returned copies with your approved sign.

[1] The maximum rating

	Item	Symbol	Rating	Note
1	Storage temperature range	Tsto	-30 ~ +70	
2	Maximum drive level	DL max	1.0 μ W max.	

[2] Recommended Operating Condition

	Item	Symbol	Rating	Note
1	Operating temperature range	Tope	-10 ~ +60	
2	Drive level	DL	0.1 μ W typ.	

[3] Electrical -CharacteristicsMeasurement temperature : 25 \pm 2

	Item	Symbol	Specifications	Conditions
1	Nominal frequency	F ₀	32.768 kHz	
2	Frequency tolerance	$\Delta f/f_0$	$\pm 20 \times 10^{-6}$	
3	Load capacitance	C _L	6.0 pF	
4	Equivalent series resistance	R ₁	50 k Ω max.	Measured with ATI 4192A Impedance analyzer. OSC LEVEL = 0.1V
5	Q-value	Q	40×10^3 min.	calculated with the following equation : $Q=(2\pi \cdot F_r \cdot L_1)/R_1$
6	Motional capacitance	C ₁	2.0 fF typ.	
7	Shunt capacitance	C ₀	0.9 pF typ.	Measured with ATI 4192A Impedance analyzer. OSC LEVEL = 0.1V
8	Turnover temperature	Tp	25 \pm 5	Measure this coefficient at 3 points of 10 , 25 , and 40 using C-MOS circuit.
9	Temperature coefficient	k	$(-3.5\pm 0.8) \times 10^{-8} / ^\circ\text{C}^2$	
10	Aging	$\Delta f/f_0$	$\pm 5 \times 10^{-6} / \text{year}$	25 \pm 3 , First year
11	Insulation resistance	IR	500 M Ω min.	Measured with ATI 4329A Insulation Resistance Meter. Apply DC100V.

(continued)

[4] Environment-proof · Mechanical property

No	Item	Specifications	Conditions	
1	High temperature storage	$f/f = \pm 5 \times 10^{-6}$	After storage under 85 for 500 hrs, measure at room temperature.	*1
2	Low temperature storage	$f/f = \pm 5 \times 10^{-6}$	After storage under -40 for 500 hrs, measure at room temperature.	*1
3	High temperature and high humidity storage	$f/f = \pm 5 \times 10^{-6}$	After storage under 60 ± 2 , 90 to 95% RH for 500 hrs, measure at room temperature.	*1
4	Thermal shock resistance	$f/f = \pm 5 \times 10^{-6}$	Measured at room temperature after 20 cycles. -25 +80 for 30 minutes.	*1
5	Mechanical shock resistance	$f/f = \pm 5 \times 10^{-6}$	Measure after free drop of the RESONATOR three times from the height of 75cm onto a wooden board.	*2
6	Vibration resistance	$f/f = \pm 5 \times 10^{-6}$	Amplitude 1.5mm and 10 ~ 60Hz with cycle time 2 ~ 3 minutes in 3 direction (X,Y,and Z axis)each for 2 hrs.	*2
7	Resistance to soldering heat	$f/f_0 = \pm 5 \times 10^{-6}$	Measured at room temperature after immersing the lead wire in a soldering bath of 300 ± 10 for 5 seconds up to a position where it is 2mm away from the root of the plug.	*1
8	Tensile strength of lead wire	$f/f_0 = \pm 5 \times 10^{-6}$	Apply a load of 500g for 30 seconds in the lead wire's axial direction.	2
9	Bending strength of lead wire	$f/f_0 = \pm 5 \times 10^{-6}$	Bending cycle : 0° 45° 0° 45° 0°	2
10	Solderability of lead wire	A minimum 95% of the area to be coated with solder	Apply resin-flux contained-solder to a soldering iron of 280 ± 5 for 5 seconds.	*2

Note:

1. The above tests no. 1 to 9 must be conducted independently (not series tests)
2. *1: Measure after 24 hours soak at room temperature .
3. *2: Measure after 2 hours soak at room temperature .
4. R1 is 60k Ω max. after the each above tests.

[5] Precautions

- (1) Temperature for soldering the lead wire shall not exceed 300°C and the soldering time shall be within 5 seconds.
- (2) Position to be soldered : Solder only the position where the lead wire is 1.0mm away from the glass seal.
Do not solder the case.
- (3) Cutting, bending and correction of lead wire : The glass seal shall be free of any crack or other damage which may deteriorate the characteristics of RESONATORS.

[6] Outgoing inspection standard

- The outgoing inspection shall be conducted as per the following standard .
- The sampling shall be performed according to the ANSI/ASQCZ1.4-1996 .

No	Item	Sampling level	AQL(%)
1	Frequency tolerance	I	1.0
2	Equivalent series resistance	I	1.0
3	Outer appearance	I	1.5
4	Others characteristics	Periodical quality inspection	

[7] Out Line Drawing

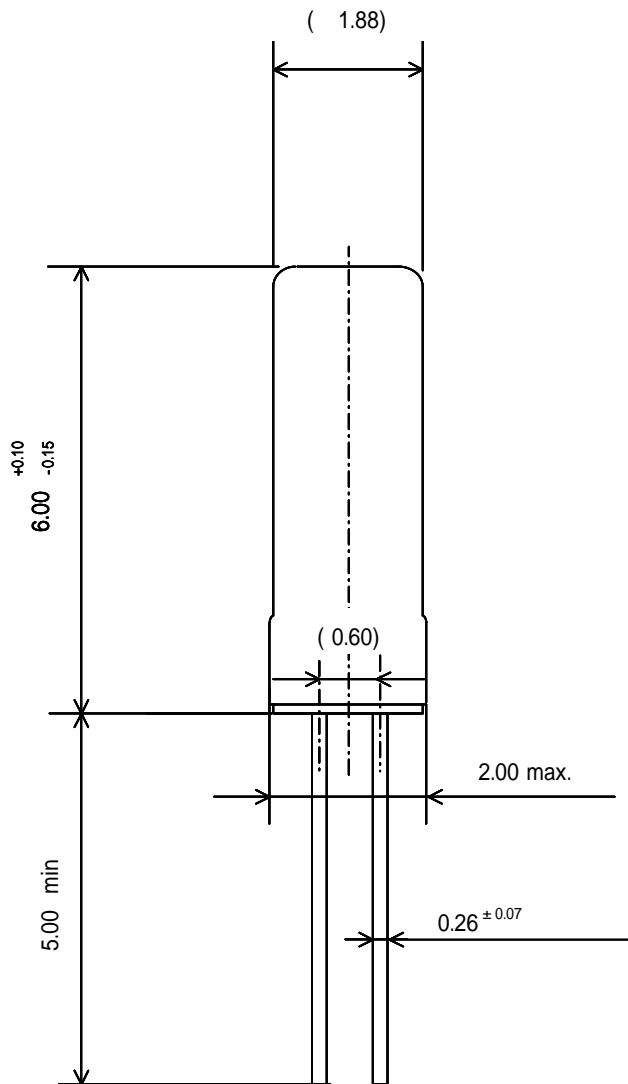

DESCRIPTION	Materials	Remarks	REMARKS
VT-200-F	Ni SnCu(2 ~ 5%Cu)		UNIT: 1 = 1 mm

Article method and packing structure

1. Bag checkmate packing specification

1) White ball case (the inner compartment) the packing structure

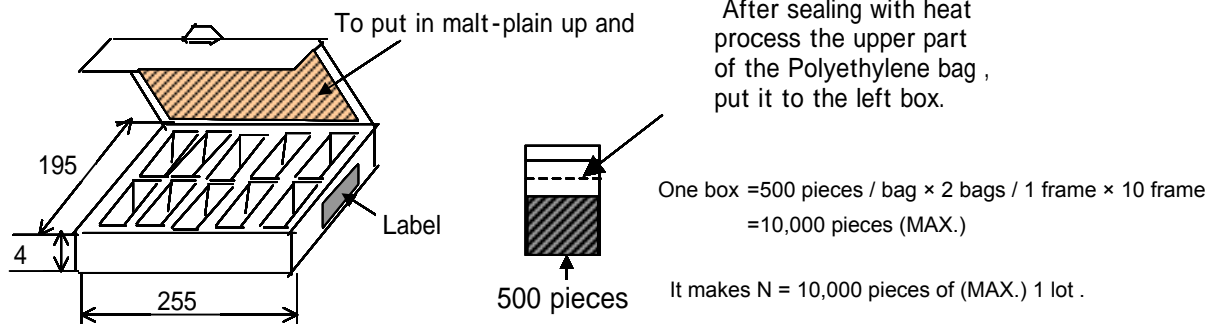

[Figure 1]

2. Outer case packing specification (the sectional plan) [Figure 3]

1) The number of Carton case (the outer case) size and white ball case (the inner compartment) [Table 1] [Figure 2]

[Table 1]

The outer case	S	B - 4	G - 2 MA (W carton case	D (W carton case)
Number of white ball case	1 box	3 boxes	10 boxes	20 boxes

Statement of delivery or designated slip to the envelope

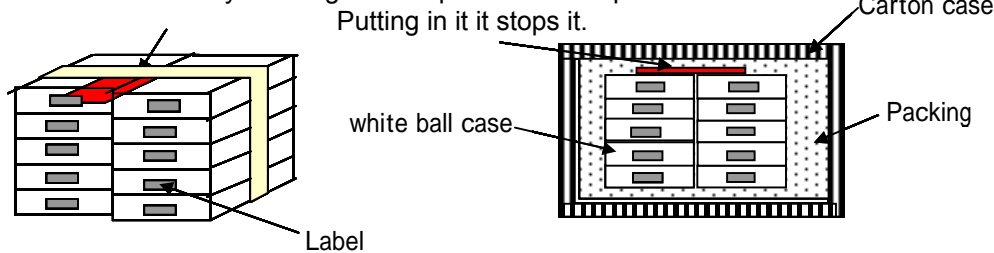

[Figure 2]

[Figure 3]

3. Sample of the label display (display department, please refer to [Figure 1] [Figure 2])

Product bar code	PART	VT-200-F
	LOTNo.	
Item bar code *	Quantity	10,000 pcs
	Calibre	32.768kHz 6.0pF /±20 × 10 ⁻⁶
Quantity Lot. No. bar code	Remarks	

PART : Our company product name
 LOT No. : Lot No. display
 Quantity : Quantity
 Calibre : Frequency, CL value, F0 deviator
 Remarks : Marking etc.
 * : Item code

4. Storage environment

A product avoids the direct ray and please store with the normal temperature and humidity .

Conformance in (the standard condition of the JIS Z8703 test place)