

## 74F433 First-In First-Out (FIFO) Buffer Memory

### General Description

The 74F433 is an expandable fall-through type high-speed First-In First-Out (FIFO) Buffer Memory that is optimized for high-speed disk or tape controller and communication buffer applications. It is organized as 64-words by 4-bits and may be expanded to any number of words or any number of bits in multiples of four. Data may be entered or extracted asynchronously in serial or parallel, allowing economical implementation of buffer memories.

The 74F433 has 3-STATE outputs that provide added versatility, and is fully compatible with all TTL families.

### Features

- Serial or parallel input
- Serial or parallel output
- Expandable without additional logic
- 3-STATE outputs
- Fully compatible with all TTL families
- Slim 24-pin package
- 9423 replacement

### Ordering Code:

Order Number	Package Number	Package Description
74F433SPC	N24C	24-Lead Plastic Dual-In-Line Package (PDIP), JEDEC MS-100, 0.300 Wide

### Logic Symbol

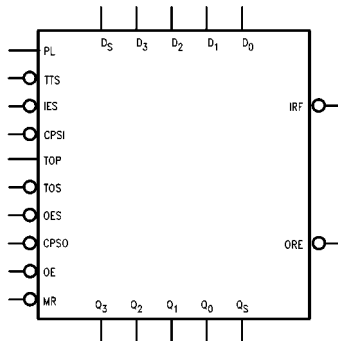

### Connection Diagram

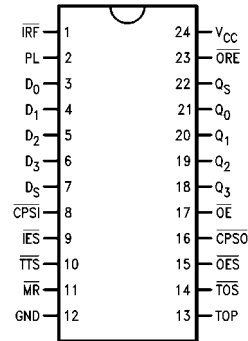

## Unit Loading/Fan Out

Pin Names	Description	U.L. HIGH/LOW	Input $I_{IH}/I_{IL}$ Output $I_{OH}/I_{OL}$
PL	Parallel Load Input	1.0/0.66	20 $\mu$ A/400 $\mu$ A
$\overline{\text{CPSI}}$	Serial Input Clock	1.0/0.66	20 $\mu$ A/400 $\mu$ A
$\overline{\text{IES}}$	Serial Input Enable	1.0/0.66	20 $\mu$ A/400 $\mu$ A
$\overline{\text{TTS}}$	Transfer to Stack Input	1.0/0.66	20 $\mu$ A/400 $\mu$ A
$\overline{\text{MR}}$	Master Reset	1.0/0.66	20 $\mu$ A/400 $\mu$ A
$\overline{\text{OES}}$	Serial Output Enable	1.0/0.66	20 $\mu$ A/400 $\mu$ A
TOP	Transfer Out Parallel	1.0/0.66	20 $\mu$ A/400 $\mu$ A
$\overline{\text{TOS}}$	Transfer Out Serial	1.0/0.66	20 $\mu$ A/400 $\mu$ A
$\overline{\text{CPSO}}$	Serial Output Clock	1.0/0.66	20 $\mu$ A/400 $\mu$ A
$\overline{\text{OE}}$	Output Enable	1.0/0.66	20 $\mu$ A/400 $\mu$ A
$D_0$ - $D_3$	Parallel Data Inputs	1.0/0.66	20 $\mu$ A/400 $\mu$ A
$D_S$	Serial Data Input	1.0/0.66	20 $\mu$ A/400 $\mu$ A
$Q_0$ - $Q_3$	Parallel Data Outputs	285/10	5.7 mA/16 mA
$Q_S$	Serial Data Output	285/10	5.7 $\mu$ A/16 mA
$\overline{\text{IRF}}$	Input Register Full	20/5	400 $\mu$ A/8 mA
$\overline{\text{ORE}}$	Output Register Empty	20/5	400 $\mu$ A/8 mA

## Block Diagram

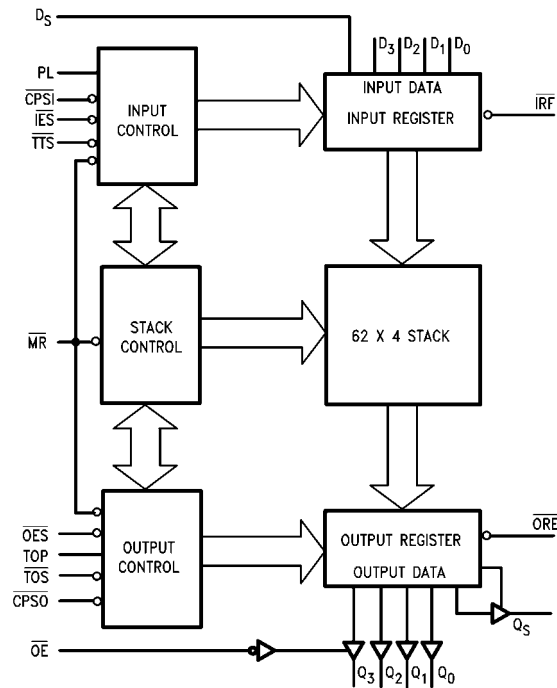

## Functional Description

As shown in the block diagram, the 74F433 consists of three sections:

1. An Input Register with parallel and serial data inputs, as well as control inputs and outputs for input handshaking and expansion.
2. A 4-bit-wide, 62-word-deep fall-through stack with self-contained control logic.
3. An Output Register with parallel and serial data outputs, as well as control inputs and outputs for output handshaking and expansion.

These three sections operate asynchronously and are virtually independent of one another.

### Input Register (Data Entry)

The Input Register can receive data in either bit-serial or 4-bit parallel form. It stores this data until it is sent to the fall-through stack, and also generates the necessary status and control signals.

This 5-bit register (see Figure 1) is initialized by setting flip-flop  $F_3$  and resetting the other flip-flops. The Q-output of

the last flip-flop (FC) is brought out as the Input Register Full (IRF) signal. After initialization, this output is HIGH.

**Parallel Entry**—A HIGH on the Parallel Load (PL) input loads the  $D_0$ – $D_3$  inputs into the  $F_0$ – $F_3$  flip-flops and sets the FC flip-flop. This forces the  $\overline{\text{IRF}}$  output LOW, indicating that the input register is full. During parallel entry, the Serial Input Clock ( $\overline{\text{CPSI}}$ ) input must be LOW.

**Serial Entry**—Data on the Serial Data ( $D_S$ ) input is serially entered into the shift register ( $F_3, F_2, F_1, F_0, \text{FC}$ ) on each HIGH-to-LOW transition of the  $\overline{\text{CPSI}}$  input when the Serial Input Enable ( $\overline{\text{IES}}$ ) signal is LOW. During serial entry, the PL input should be LOW.

After the fourth clock transition, the four data bits are located in flip-flops  $F_0$ – $F_3$ . The FC flip-flop is set, forcing the  $\overline{\text{IRF}}$  output LOW and internally inhibiting  $\overline{\text{CPSI}}$  pulses from affecting the register. Figure 2 illustrates the final positions in an 74F433 resulting from a 256-bit serial bit train ( $B_0$  is the first bit,  $B_{255}$  the last).

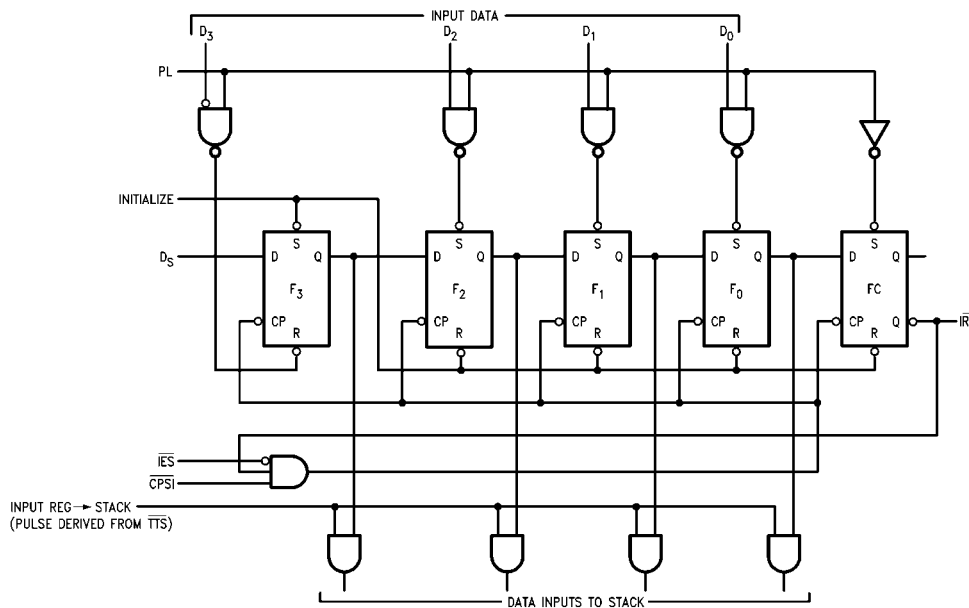
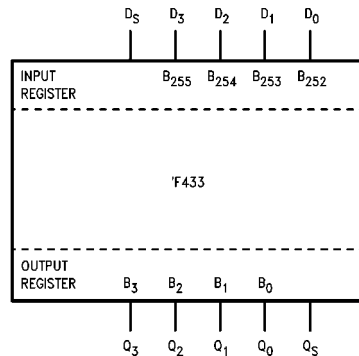

FIGURE 1. Conceptual Input Section



**FIGURE 2. Final Positions in an 74F433 Resulting from a 256-Bit Serial Train**

**Fall-Through Stack**—The outputs of flip-flops  $F_0$ – $F_3$  feed the stack. A LOW level on the Transfer to Stack ( $\overline{TTS}$ ) input initiates a fall-through action; if the top location of the stack is empty, data is loaded into the stack and the input register is re-initialized. (Note that this initialization is delayed until PL is LOW). Thus, automatic FIFO action is achieved by connecting the IRF output to the  $\overline{TTS}$  input.

An RS-type flip-flop (the initialization flip-flop) in the control section records the fact that data has been transferred to the stack. This prevents multiple entry of the same word into the stack even though IRF and  $\overline{TTS}$  may still be LOW; the initialization flip-flop is not cleared until PL goes LOW.

Once in the stack, data falls through automatically, pausing only when it is necessary to wait for an empty next location. In the 74F433, the master reset ( $\overline{MR}$ ) input only initializes the stack control section and does not clear the data.

#### Output Register

The Output Register (see Figure 3) receives 4-bit data words from the bottom stack location, stores them, and outputs data on a 3-STATE, 4-bit parallel data bus or on a 3-STATE serial data bus. The output section generates and receives the necessary status and control signals.

**Parallel Extraction**—When the FIFO is empty after a LOW pulse is applied to the MR input, the Output Register Empty ( $\overline{ORE}$ ) output is LOW. After data has been entered into the FIFO and has fallen through to the bottom stack location, it is transferred into the output register, if the Transfer Out Parallel (TOP) input is HIGH. As a result of the data trans-

fer,  $\overline{ORE}$  goes HIGH, indicating valid data on the data outputs (provided that the 3-STATE buffer is enabled). The TOP input can then be used to clock out the next word.

When TOP goes LOW,  $\overline{ORE}$  also goes LOW, indicating that the output data has been extracted; however, the data itself remains on the output bus until a HIGH level on TOP permits the transfer of the next word (if available) into the output register. During parallel data extraction, the serial output clock ( $\overline{CPSO}$ ) line should be LOW. The Transfer Out Serial ( $\overline{TOS}$ ) line should be grounded for single-slice operation or connected to the appropriate  $\overline{ORE}$  line for expanded operation (refer to the "Expansion" section).

The TOP signal is not edge-triggered. Therefore, if TOP goes HIGH before data is available from the stack but data becomes available before TOP again goes LOW, that data is transferred into the output register. However, internal control circuitry prevents the same data from being transferred twice. If TOP goes HIGH and returns to LOW before data is available from the stack,  $\overline{ORE}$  remains LOW, indicating that there is no valid data at the outputs.

**Serial Extraction**—When the FIFO is empty after a LOW is applied to the MR input, the  $\overline{ORE}$  output is LOW. After data has been entered into the FIFO and has fallen through to the bottom stack location, it is transferred into the output register, if the  $\overline{TOS}$  input is LOW and TOP is HIGH. As a result of the data transfer,  $\overline{ORE}$  goes HIGH, indicating that valid data is in the register.

The 3-STATE Serial Data Output ( $Q_S$ ) is automatically enabled and puts the first data bit on the output bus. Data is serially shifted out on the HIGH-to-LOW transition of  $\overline{CPSO}$ . To prevent false shifting,  $\overline{CPSO}$  should be LOW when the new word is being loaded into the output register. The fourth transition empties the shift register, forces  $\overline{ORE}$  LOW, and disables the serial output,  $Q_S$ . For serial operation, the  $\overline{ORE}$  output may be tied to the  $\overline{TOS}$  input, requesting a new word from the stack as soon as the previous one has been shifted out.

#### Expansion

**Vertical Expansion**—The 74F433 may be vertically expanded, without external components, to store more words. The interconnections necessary to form a 190-word by 4-bit FIFO are shown in Figure 4. Using the same technique, any FIFO of  $(63n+1)$ -words by 4-bits can be configured, where n is the number of devices. Note that expansion does not sacrifice any of the 74F433 flexibility for serial/parallel input and output.

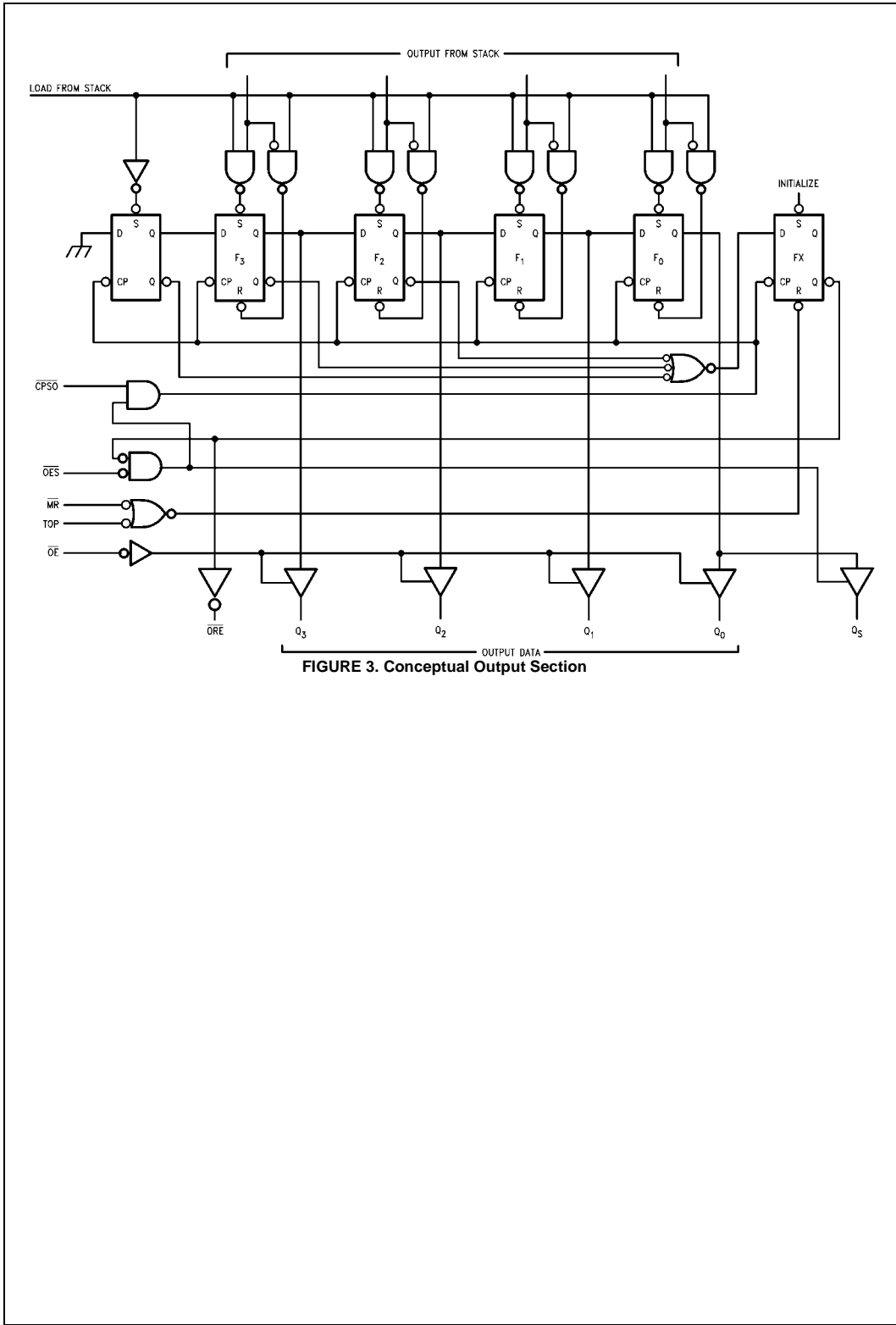

FIGURE 3. Conceptual Output Section

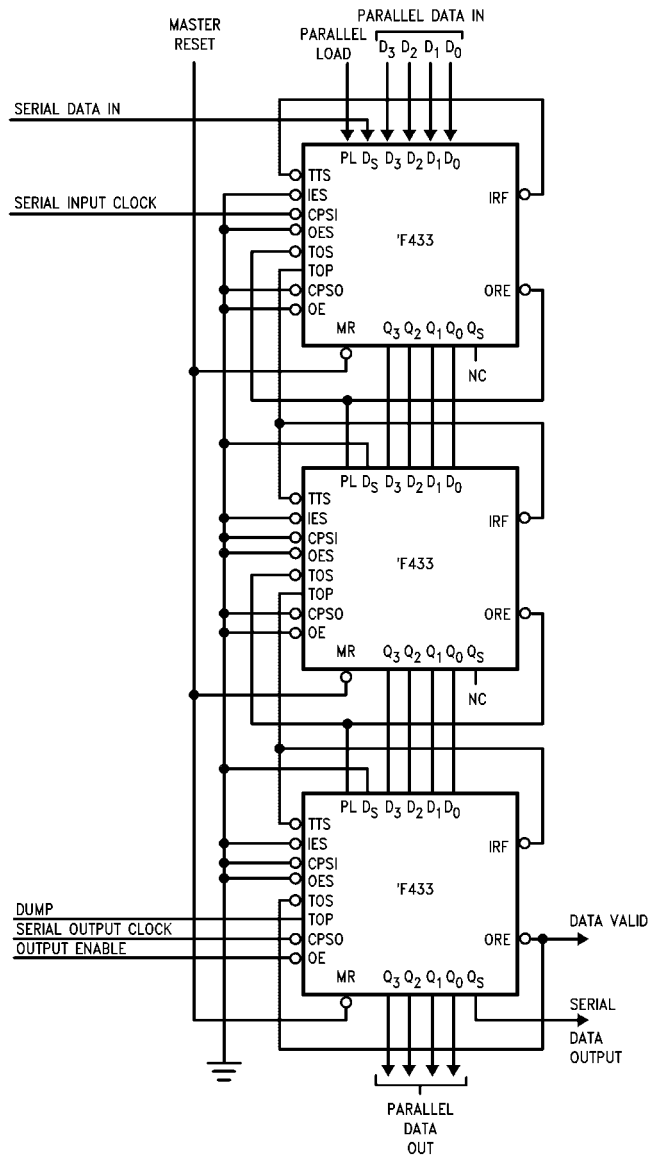

FIGURE 4. A Vertical Expansion Scheme

**Horizontal Expansion**—The 74F433 can be horizontally expanded, without external logic, to store long words (in multiples of 4-bits). The interconnections necessary to form a 64-word by 12-bit FIFO are shown in Figure 5. Using the same technique, any FIFO of 64-words by 4n-bits can be constructed, where n is the number of devices.

The right-most (most significant) device is connected to the TTS inputs of all devices. Similarly, the ORE output of the most significant device is connected to the TOS inputs of all devices. As in the vertical expansion scheme, horizontal expansion does not sacrifice any of the 74F433 flexibility for serial/parallel input and output.

It should be noted that the horizontal expansion scheme shown in Figure 5 exacts a penalty in speed.

**Horizontal and Vertical Expansion**—The 74F433 can be expanded in both the horizontal and vertical directions without any external components and without sacrificing any of its FIFO flexibility for serial/parallel input and output. The interconnections necessary to form a 127-word by 16-bit FIFO are shown in Figure 6. Using the same technique, any FIFO of (63m+1)-words by 4n-bits can be configured, where m is the number of devices in a column and n is the number of devices in a row. Figure 7 and Figure 8 illustrate the timing diagrams for serial data entry and extraction for the FIFO shown in Figure 6. Figure 9 illustrates the final

positions of bits in an expanded 74F433 FIFO resulting from a 2032-bit serial bit train.

**Interlocking Circuitry**—Most conventional FIFO designs provide status signal analogous to IRF and ORE. However, when these devices are operated in arrays, variations in unit-to-unit operating speed require external gating to ensure that all devices have completed an operation. The 74F433 incorporates simple but effective 'master/slave' interlocking circuitry to eliminate the need for external gating.

In the 74F433 array of Figure 6, devices 1 and 5 are the row masters; the other devices are slaves to the master in their rows. No slave in a given row initializes its input register until it has received a LOW on its IES input from a row master or a slave of higher priority.

Similarly, the ORE outputs of slaves do not go HIGH until their inputs have gone HIGH. This interlocking scheme ensures that new input data may be accepted by the array when the IRF output of the final slave in that row goes HIGH and that output data for the array may be extracted when the ORE output of the final slave in the output row goes HIGH.

The row master is established by connecting its IES input to ground, while a slave receives its IES input from the IRF output of the next-higher priority device. When an array of 74F433 FIFOs is initialized with a HIGH on the MR inputs of all devices, the IRF outputs of all devices are HIGH. Thus, only the row master receives a LOW on the IES input during initialization.

Figure 10 is a conceptual logic diagram of the internal circuitry that determines master/slave operation. When MR and IES are LOW, the master latch is set. When TTS goes LOW, the initialization flip-flop is set. If the master latch is HIGH, the input register is immediately initialized and the initialization flip-flop reset. If the master latch is reset, the input register is not initialized until IES goes LOW. In array operation, activating TTS initiates a ripple input register initialization from the row master to the last slave.

A similar operation takes place for the output register. Either a TOS or TOP input initiates a load-from-stack operation and sets the ORE request flip-flop. If the master latch is set, the last output register flip-flop is set and the ORE line goes HIGH. If the master latch is reset, the ORE output is LOW until a Serial Output Enable (OES) input is received.

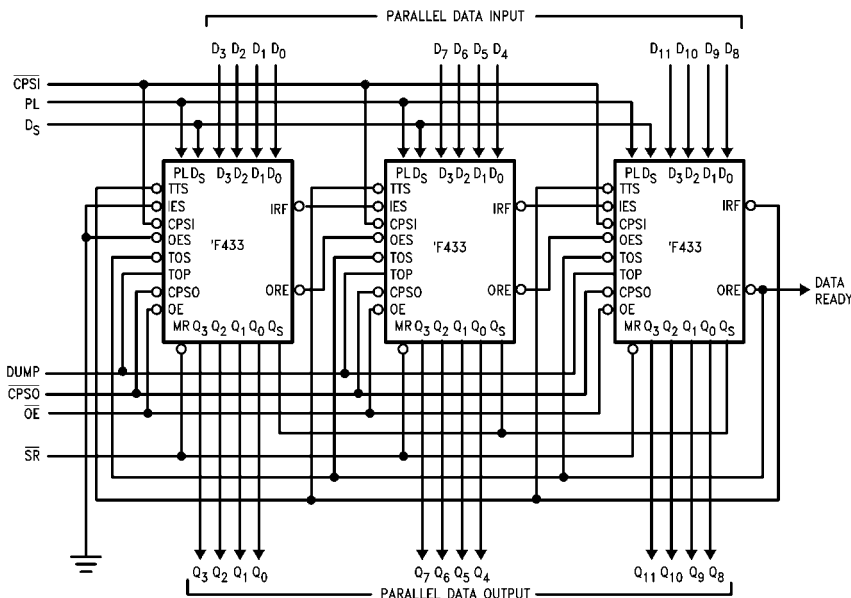

FIGURE 5. A Horizontal Expansion Scheme

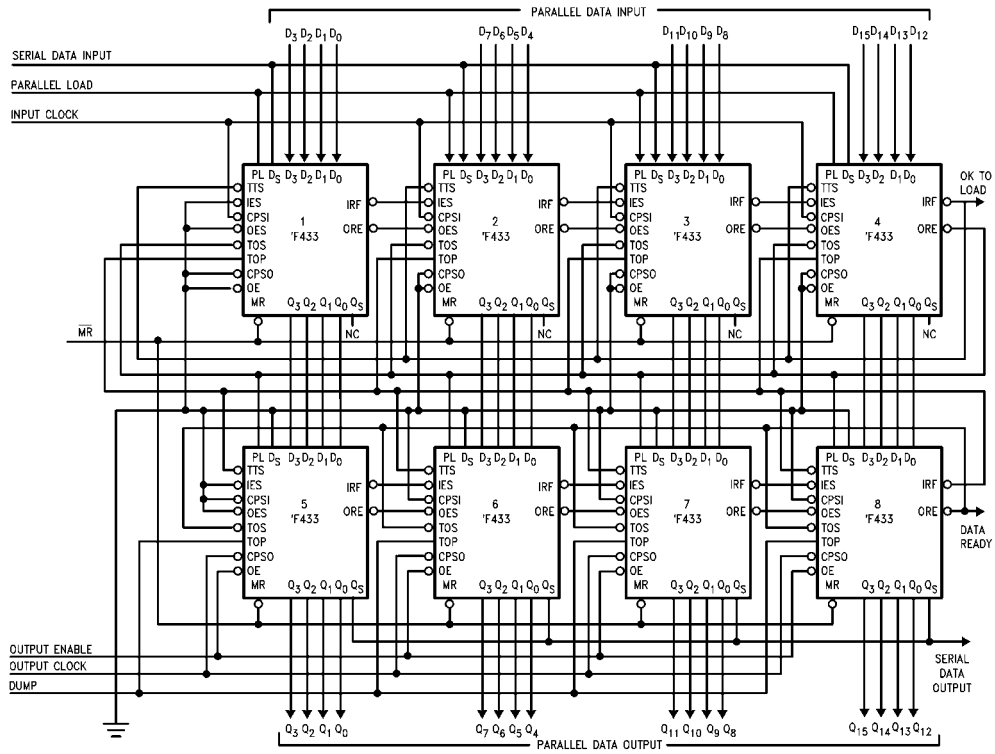

FIGURE 6. A 127 x 16 FIFO Array

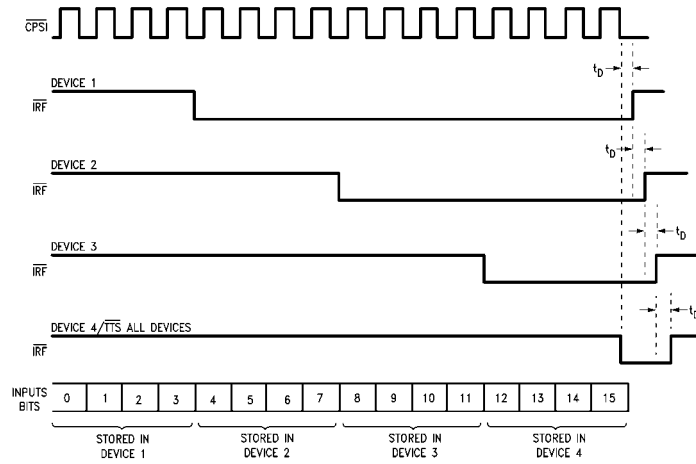

FIGURE 7. Serial Data Entry for Array of Figure



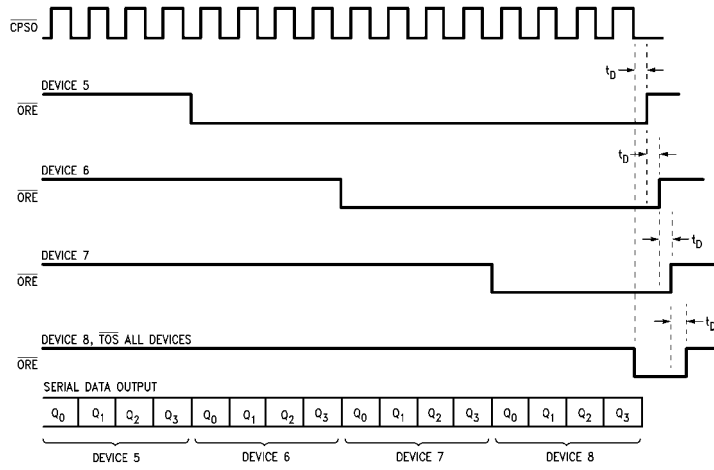

FIGURE 8. Serial Data Extraction for Array of Figure

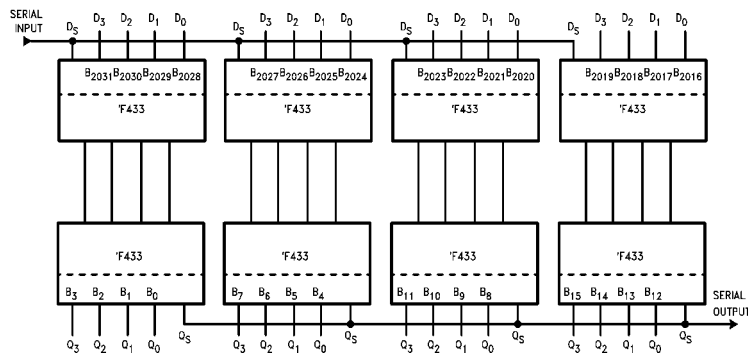

FIGURE 9. Final Position of a 2032-Bit Serial Input

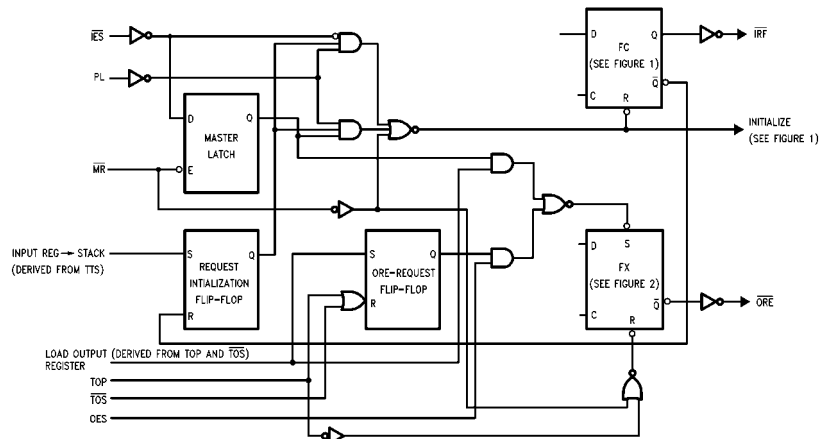

FIGURE 10. Conceptual Diagram, Interlocking Circuitry

**Absolute Maximum Ratings** (Note 1)

Storage Temperature	-65°C to +150°C
Ambient Temperature under Bias	-55°C to +125°C
Junction Temperature under Bias	-55°C to +150°C
V <sub>CC</sub> Pin Potential to Ground Pin	-0.5V to +7.0V
Input Voltage (Note 2)	-0.5V to +7.0V
Input Current (Note 2)	-30 mA to +5.0 mA
Voltage Applied to Output in HIGH State (with V <sub>CC</sub> = 0V)	
Standard Output	-0.5V to V <sub>CC</sub>
3-STATE Output	-0.5V to +5.5V
Current Applied to Output in LOW State (Max)	twice the rated I <sub>OL</sub> (mA)

**Recommended Operating Conditions**

Free Air Ambient Temperature	0°C to +70°C
Supply Voltage	+4.5V to +5.5V

**Note 1:** Absolute maximum ratings are values beyond which the device may be damaged or have its useful life impaired. Functional operation under these conditions is not implied.

**Note 2:** Either voltage limit or current limit is sufficient to protect inputs.

**DC Electrical Characteristics**

Symbol	Parameter	Min	Typ	Max	Units	V <sub>CC</sub>	Conditions
V <sub>IH</sub>	Input HIGH Voltage	2.0			V		Recognized as a HIGH Signal
V <sub>IL</sub>	Input LOW Voltage			0.8	V		Recognized as a LOW Signal
V <sub>CD</sub>	Input Clamp Diode Voltage			-1.5	V	Min	I <sub>IN</sub> = -18 mA
V <sub>OH</sub>	Output HIGH Voltage	10% V <sub>CC</sub> 10% V <sub>CC</sub> 5% V <sub>CC</sub> 5% V <sub>CC</sub>	2.4 2.4 2.7 2.7		V	Min	I <sub>OH</sub> = 400 μA ( $\overline{ORE}$ , $\overline{IRF}$ ) I <sub>OH</sub> = 5.7 mA (Q <sub>n</sub> , Q <sub>s</sub> ) I <sub>OH</sub> = 400 μA ( $\overline{ORE}$ , $\overline{IRF}$ ) I <sub>OH</sub> = 5.7 mA (Q <sub>n</sub> , Q <sub>s</sub> )
V <sub>OL</sub>	Output LOW Voltage	10% V <sub>CC</sub>		0.50	V	Min	I <sub>OL</sub> = 16 mA (Q <sub>n</sub> , Q <sub>s</sub> )
I <sub>IH</sub>	Input HIGH Current			5.0	μA	Max	V <sub>IN</sub> = 2.7V
I <sub>BVI</sub>	Input HIGH Current Breakdown Test			7.0	μA	Max	V <sub>IN</sub> = 7.0V
I <sub>CEX</sub>	Output HIGH Leakage Current			50	μA	Max	V <sub>OUT</sub> = V <sub>CC</sub>
V <sub>ID</sub>	Input Leakage Test	4.75			V	0.0	I <sub>ID</sub> = 1.9 μA All Other Pins Grounded
I <sub>OD</sub>	Output Leakage Circuit Current			3.75	μA	0.0	V <sub>IOD</sub> = 150 mV All Other Pins Grounded
I <sub>IL</sub>	Input LOW Current			-0.4	mA	Max	V <sub>IN</sub> = 0.5V
I <sub>OZH</sub>	Output Leakage Current			50	μA	Max	V <sub>OUT</sub> = 2.7V (Q <sub>n</sub> , Q <sub>s</sub> )
I <sub>OZL</sub>	Output Leakage Current			-50	μA	Max	V <sub>OUT</sub> = 0.5V (Q <sub>n</sub> , Q <sub>s</sub> )
I <sub>OS</sub>	Output Short-Circuit Current	-20		-130	mA	Max	V <sub>OUT</sub> = 0V
I <sub>CC</sub>	Power Supply Current		150	215	mA	Max	

AC Electrical Characteristics							
Symbol	Parameter	$T_A = +25^\circ\text{C}$ $V_{CC} = +5.0\text{V}$ $C_L = 50\text{ pF}$		$T_A = 0^\circ\text{C to } +70^\circ\text{C}$ $V_{CC} = +5.0\text{V}$ $C_L = 50\text{ pF}$		Units	Figure Number
		Min	Max	Min	Max		
$t_{PHL}$	Propagation Delay, Negative-Going CPSI to $\overline{\text{IRF}}$ Output	2.0	17.0	2.0	18.0	ns	Figure 11 Figure 12
$t_{PLH}$	Propagation Delay, Negative-Going $\overline{\text{TTS}}$ to $\overline{\text{IRF}}$	9.0	34.0	8.0	38.0		
$t_{PLH}$	Propagation Delay, Negative-Going $\overline{\text{CPSO}}$ to $Q_S$ Output	4.0	25.0	3.0	27.0	ns	Figure 13 Figure 14
$t_{PHL}$	Propagation Delay, Positive-Going TOP to $Q_0$ - $Q_3$ Outputs	8.0	35.0	7.0	38.0		
$t_{PHL}$	Propagation Delay, Negative-Going $\overline{\text{CPSO}}$ to $\overline{\text{ORE}}$	7.0	25.0	6.0	28.0	ns	Figure 13 Figure 14
$t_{PHL}$	Propagation Delay, Negative-Going TOP to $\overline{\text{ORE}}$	6.0	26.0	6.0	28.0		
$t_{PLH}$	Propagation Delay, Positive-Going TOP to $\overline{\text{ORE}}$	13.0	48.0	12.0	51.0	ns	Figure 15
$t_{PLH}$	Propagation Delay, Negative-Going $\overline{\text{TOS}}$ to Positive-Going $\overline{\text{ORE}}$	13.0	45.0	12.0	50.0		
$t_{PHL}$	Propagation Delay, Positive- Going PL to Negative-Going $\overline{\text{IRF}}$	4.0	22.0	4.0	23.0	ns	Figure 17 Figure 18
$t_{PLH}$	Propagation Delay, Negative- Going PL to Positive-Going $\overline{\text{IRF}}$	7.0	31.0	6.0	35.0		
$t_{PLH}$	Propagation Delay, Positive-Going $\overline{\text{OES}}$ to $\overline{\text{ORE}}$	9.0	38.0	8.0	44.0	ns	Figure 18
$t_{PLH}$	Propagation Delay Positive- $\overline{\text{IRF}}$ Going $\overline{\text{IES}}$ to Positive-Going	5.0	25.0	5.0	27.0		
$t_{PHL}$	Propagation Delay MR to $\overline{\text{ORE}}$	7.0	28.0	7.0	31.0	ns	Figure 16
$t_{PLH}$	Propagation Delay MR to $\overline{\text{IRF}}$	5.0	27.0	5.0	30.0		
$t_{PZH}$	Enable Time $\overline{\text{OE}}$ to $Q_0$ - $Q_3$	1.0	16.0	1.0	18.0	ns	
$t_{PZL}$	Disable Time $\overline{\text{OE}}$ to $Q_0$ - $Q_3$	1.0	14.0	1.0	16.0		
$t_{PHZ}$	Enable Time Negative-Going $\overline{\text{OES}}$ to $Q_S$	1.0	10.0	1.0	12.0	ns	
$t_{PZL}$	Disable Time Negative-Going $\overline{\text{OES}}$ to $Q_S$	1.0	14.0	1.0	15.0		
$t_{PHZ}$	Enable Time $\overline{\text{TOS}}$ to $Q_S$	1.0	35.0	1.0	42.0	ns	
$t_{PZL}$	Disable Time $\overline{\text{TOS}}$ to $Q_S$	1.0	35.0	1.0	39.0		
$t_{DFT}$	Fall-Through Time	0.2	0.9	0.2	1.0	ns	Figure 16
$t_{AP}$	Parallel Appearance Time $\overline{\text{ORE}}$ to $Q_0$ - $Q_3$	-20.0	-2.0	-20.0	-2.0		
$t_{AS}$	Serial Appearance Time $\overline{\text{ORE}}$ to $Q_S$	-20.0	5.0	-20.0	5.0	ns	

AC Operating Requirements							
Symbol	Parameter	$T_A = +25^\circ\text{C}$ $V_{CC} = +5.0\text{V}$		$T_A = 0^\circ\text{C to } +70^\circ\text{C}$ $V_{CC} = +5.0\text{V}$		Units	Figure Number
		Min	Max	Min	Max		
$t_S(\text{H})$	Setup Time, HIGH or LOW	7.0		7.0		ns	Figure 11 Figure 12
$t_S(\text{L})$	$D_S$ to Negative $\overline{\text{CPSI}}$	7.0		7.0			
$t_H(\text{H})$	Hold Time, HIGH or LOW	2.0		2.0		ns	Figure 11 Figure 12
$t_H(\text{L})$	$D_S$ to $\overline{\text{CPSI}}$	2.0		2.0			
$t_S(\text{L})$	Setup Time, LOW $\overline{\text{TTS}}$ to $\overline{\text{IRF}}$ , Serial or Parallel Mode	0.0		0.0		ns	Figure 11 Figure 12 Figure 17 Figure 18
$t_S(\text{L})$	Setup Time, LOW Negative-Going $\overline{\text{ORE}}$ to Negative-Going $\overline{\text{TOS}}$	0.0		0.0		ns	Figure 13 Figure 14
$t_S(\text{L})$	Setup Time, LOW Negative-Going $\overline{\text{IES}}$ to $\overline{\text{CPSI}}$	8.0		9.0		ns	Figure 12
$t_S(\text{L})$	Setup Time, LOW Negative-Going $\overline{\text{TTS}}$ to $\overline{\text{CPSI}}$	30.0		33.0			
$t_S(\text{H})$	Setup Time, HIGH or LOW	0.0		0.0		ns	
$t_S(\text{L})$	Parallel Inputs to PL	0.0		0.0			
$t_H(\text{H})$	Hold Time, HIGH or LOW	4.0		4.0		ns	
$t_H(\text{L})$	Parallel Inputs to PL	4.0		4.0			
$t_W(\text{H})$	$\overline{\text{CPSI}}$ Pulse Width	10.0		11.0		ns	Figure 11 Figure 12
$t_W(\text{L})$	HIGH or LOW	5.0		6.0			
$t_W(\text{H})$	PL Pulse Width, HIGH	7.0		9.0		ns	Figure 17 Figure 18
$t_W(\text{L})$	$\overline{\text{TTS}}$ Pulse Width, LOW Serial or Parallel Mode	7.0		9.0		ns	Figure 11 Figure 12 Figure 13 Figure 14
$t_W(\text{L})$	$\overline{\text{MR}}$ Pulse Width, LOW	7.0		9.0		ns	Figure 16
$t_W(\text{H})$	TOP Pulse Width	14.0		16.0		ns	Figure 15
$t_W(\text{L})$	HIGH or LOW	7.0		7.0			
$t_W(\text{H})$	$\overline{\text{CPSO}}$ Pulse Width	14.0		16.0		ns	Figure 13 Figure 14
$t_W(\text{L})$	HIGH or LOW	7.0		7.0			
$t_{\text{REC}}$	Recovery Time $\overline{\text{MR}}$ to Any Input	8.0		15.0		ns	Figure 16

Timing Waveforms

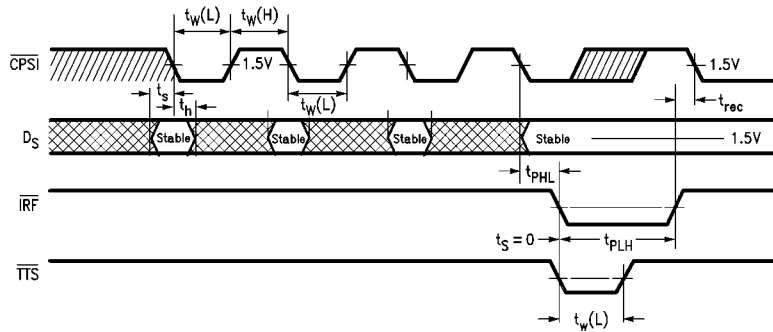

Conditions: Stack not full,  $\overline{IES}$ , PL LOW

FIGURE 11. Serial Input, Unexpanded or Master Operation

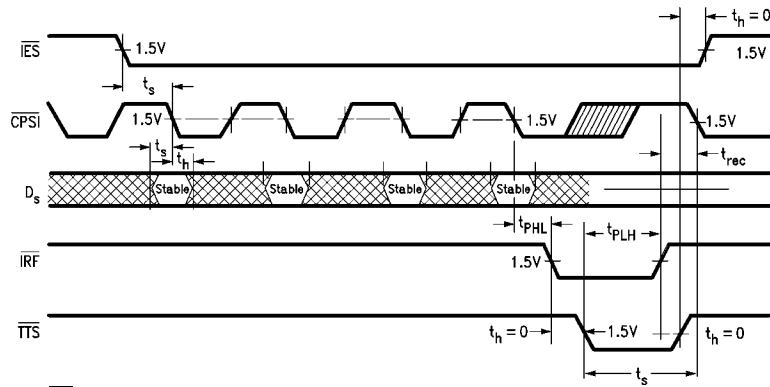

Conditions: Stack not full,  $\overline{IES}$  HIGH when initiated, PL LOW

FIGURE 12. Serial Input, Expanded Slave Operation

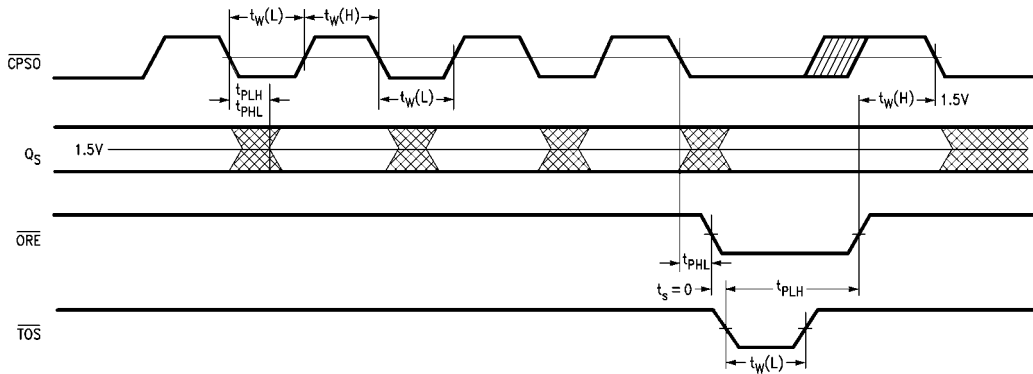

Conditions: Data in stack, TOP HIGH,  $\overline{IES}$  LOW when initiated,  $\overline{OES}$  LOW

FIGURE 13. Serial Output, Unexpanded or Master Operation

Timing Waveforms (Continued)

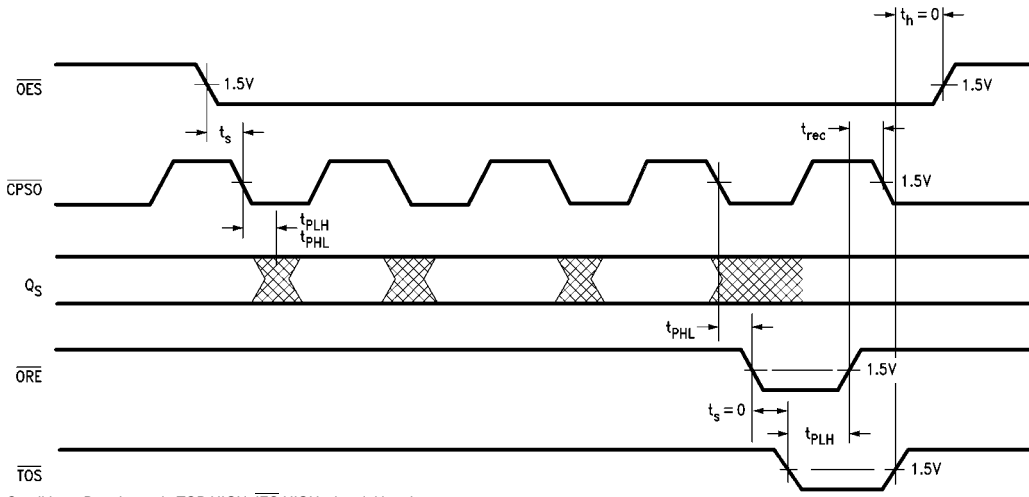

Conditions: Data in stack, TOP HIGH,  $\overline{IES}$  HIGH when initiated

FIGURE 14. Serial Output, Slave Operation

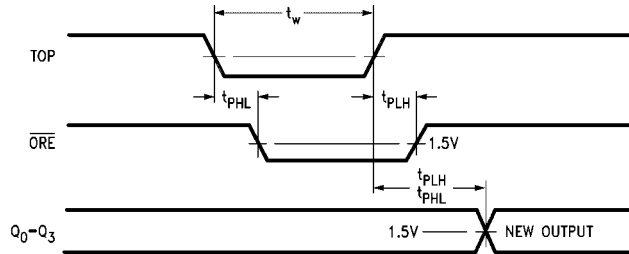

Conditions:  $\overline{IES}$  LOW when initiated,  $\overline{OE}$ ,  $\overline{CPSO}$  LOW; data available in stack

FIGURE 15. Parallel Output, 4-Bit Word or Master in Parallel Expansion

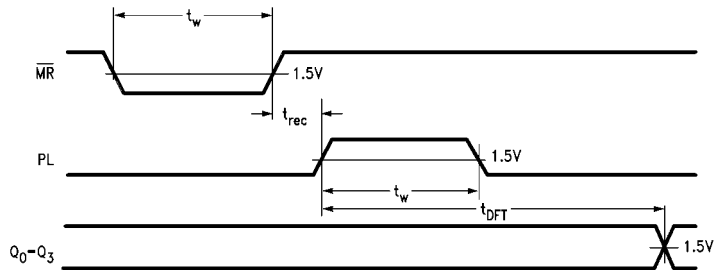

Conditions:  $\overline{TTS}$  connected to  $\overline{IRF}$ ,  $\overline{TOS}$  connected to  $\overline{ORE}$ ,  $\overline{IES}$ ,  $\overline{OES}$ ,  $\overline{OE}$ ,  $\overline{CPSO}$  LOW, TOP HIGH

FIGURE 16. Fall Through Time

## Timing Waveforms (Continued)

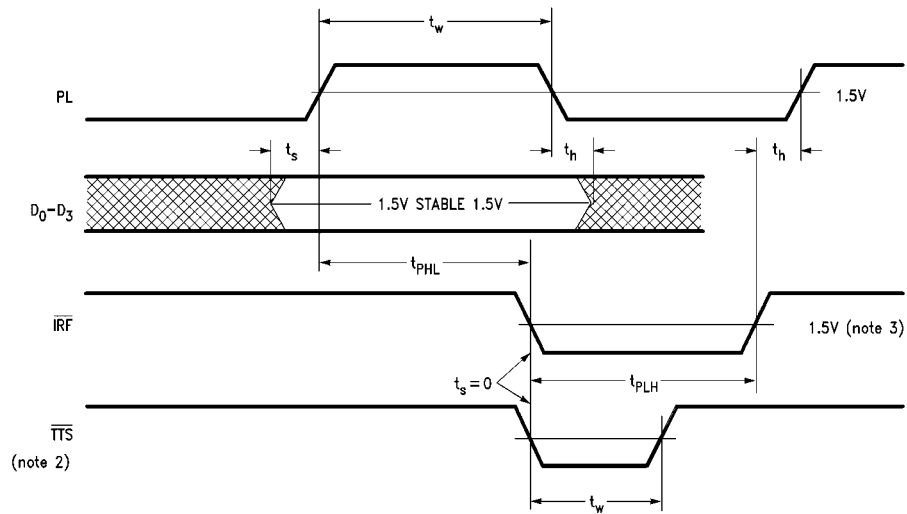

Conditions: Stack not full,  $\overline{\text{IES}}$  LOW when initialized

**NOTE A:**  $\overline{\text{TTS}}$  normally connected to  $\overline{\text{IRF}}$ .

**NOTE B:** If stack is full,  $\overline{\text{IRF}}$  will stay LOW.

**FIGURE 17. Parallel Load Mode, 4-Bit Word (Unexpanded) or Master in Parallel Expansion**

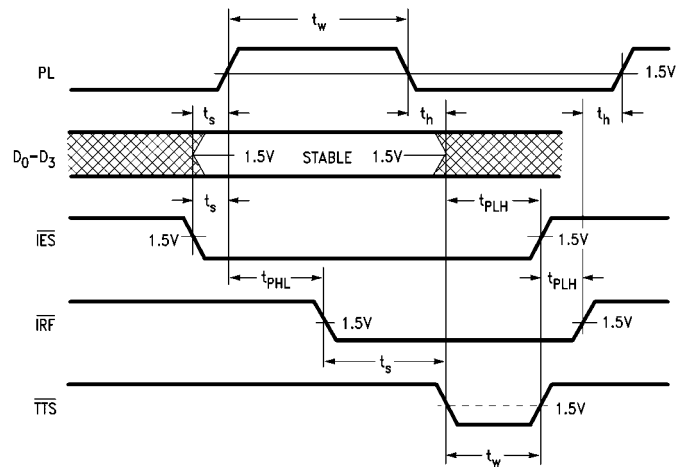

Conditions: Stack not full, device initialized (Note 3) with  $\overline{\text{IES}}$  HIGH

**Note 3:** Initialization requires a master reset to occur after power has been applied.

**FIGURE 18. Parallel Load, Slave Mode**

**Physical Dimensions** inches (millimeters) unless otherwise noted

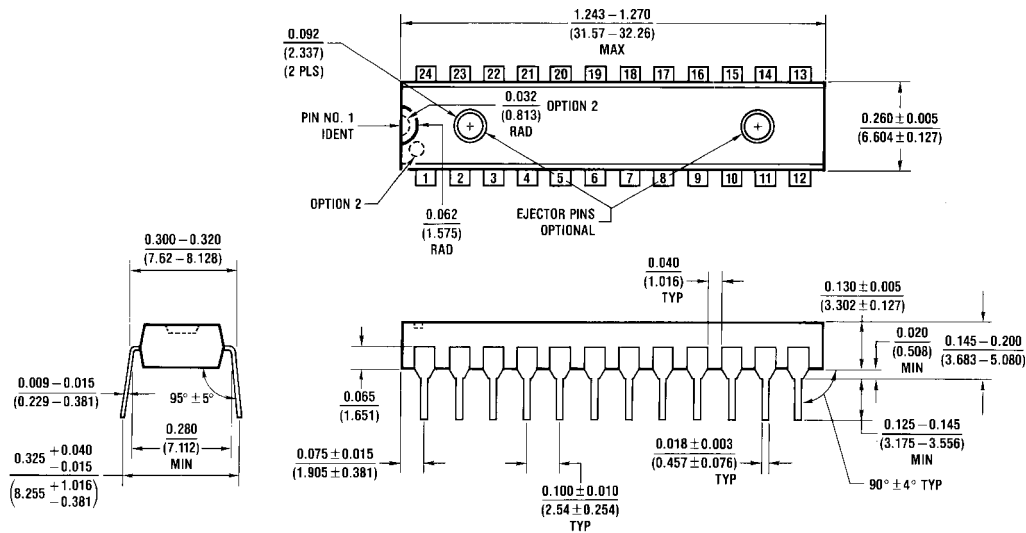

N24C (REV F)

**24-Lead Plastic Dual-In-Line Package (PDIP), JEDEC MS-100, 0.300 Wide Package Number N24C**

Fairchild does not assume any responsibility for use of any circuitry described, no circuit patent licenses are implied and Fairchild reserves the right at any time without notice to change said circuitry and specifications.

**LIFE SUPPORT POLICY**

FAIRCHILD'S PRODUCTS ARE NOT AUTHORIZED FOR USE AS CRITICAL COMPONENTS IN LIFE SUPPORT DEVICES OR SYSTEMS WITHOUT THE EXPRESS WRITTEN APPROVAL OF THE PRESIDENT OF FAIRCHILD SEMICONDUCTOR CORPORATION. As used herein:

1. Life support devices or systems are devices or systems which, (a) are intended for surgical implant into the body, or (b) support or sustain life, and (c) whose failure to perform when properly used in accordance with instructions for use provided in the labeling, can be reasonably expected to result in a significant injury to the user.
2. A critical component in any component of a life support device or system whose failure to perform can be reasonably expected to cause the failure of the life support device or system, or to affect its safety or effectiveness.

[www.fairchildsemi.com](http://www.fairchildsemi.com)