

E1103 EVALUATION ASSEMBLY USER GUIDE

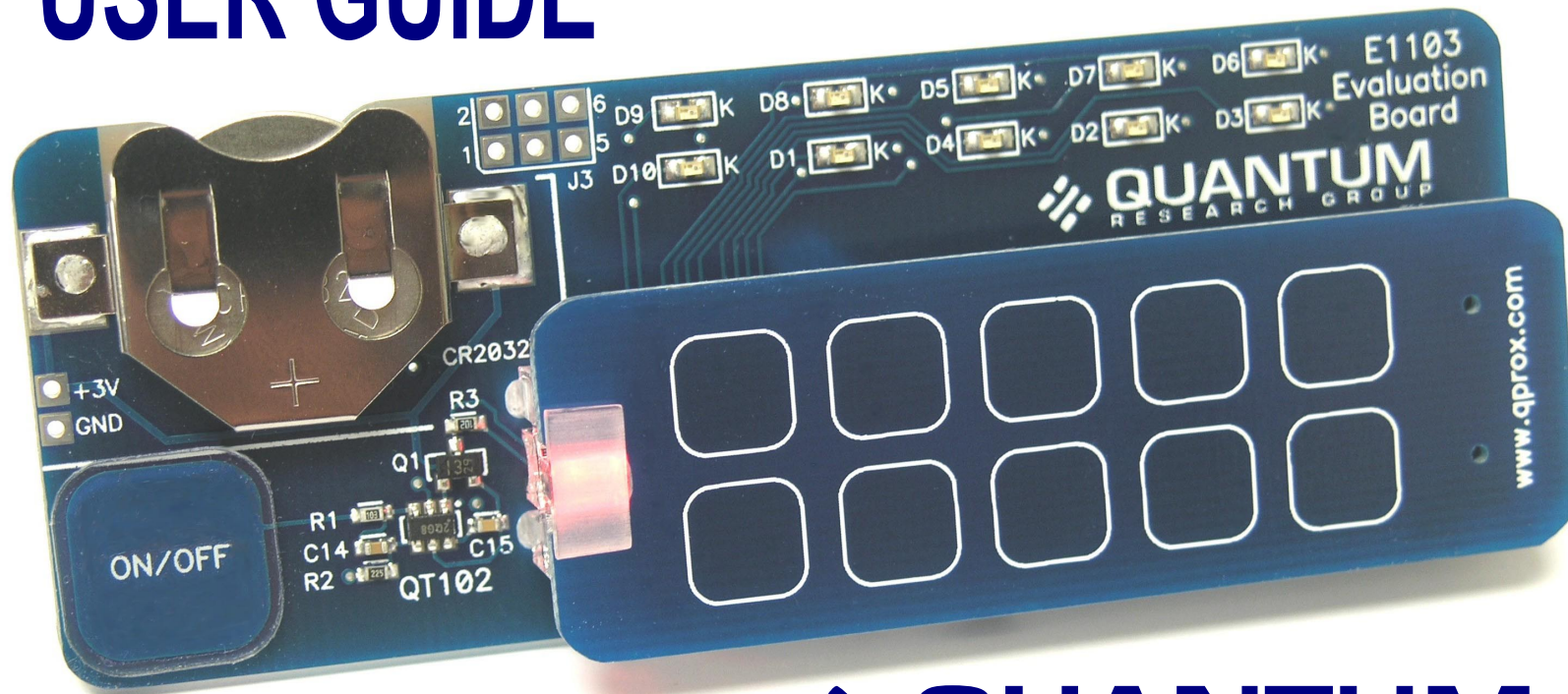

www.qprox.com

 **QUANTUM**
RESEARCH GROUP

Using the E1103:

This kit is designed for the evaluation and development of applications using the QT1103-ISG Integrated Circuit (IC). In this example the QT1103-ISG is run in Simplified mode.

Refer to the QT1103-ISG datasheet for details (see www.qprox.com/downloads).

- Ensure the E1103 Keyboard PCB is connected to J2 on the E1103 Main PCB.
- Select desired Adjacent Key Suppression (AKS) mode by moving the 2-way Jumper at J1.
- Insert the battery provided into the battery holder on the E1103 Main board.
Ensure that the battery has the correct orientation (negative (-) side to board) or the E1103 will not work.
- Touch ON/OFF - The LED (D11) under the standoff will illuminate to indicate power to QT1103-ISG.
- Touch any of the 10 key(s) on the E1103 keyboard and the corresponding LED(s) will illuminate.

Auto Power-Off: The E1103 will power off after approximately 15 minutes. (Using the auto shut-off features of the QT102-ISG fitted)

An external power supply can be used instead of a battery.

WARNING: if an external power supply is used then the battery **MUST** be removed.

Schematic:

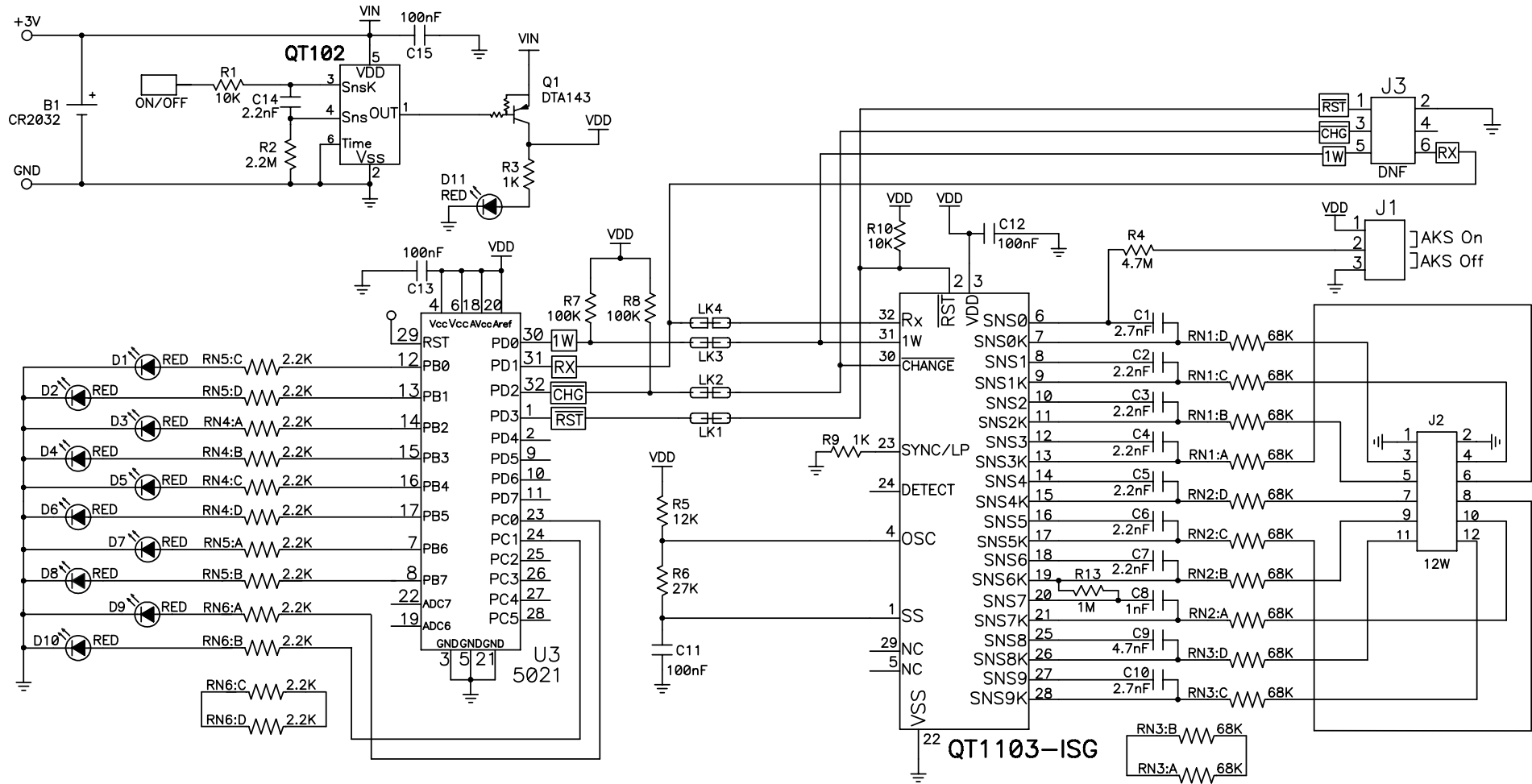

AKS Mode:

On the E1103, AKS is a global setting. Refer to the QT1103-ISG datasheet for details. The AKS mode is changed by moving the 2-way Jumper fitted to J1 as indicated.

- If set to 'On': When touching multiple keys, only the LED associated with the key with the strongest signal is lit.
- If set to 'Off': When touching multiple keys, all associated LEDs will be lit.

External Input:

The E1103 can be connected to User electrodes, using connector J2. The values of C1-C10 (sample capacitors) may require changing.

External Output:

The output of the QT1103-ISG can be accessed using J3. The tracks at LK1-4 can be cut to disconnect the QT1103-ISG from U3, which is the IC used to drive the LEDs on the E1103 Main Board.

Troubleshooting:

Problem	Potential Solution
E1103 does not work	<p>If the Power LED is off, the 15 minute timeout may have been exceeded. Touch ON/OFF to restore power.</p> <p>If using a battery, check that the negative (-) side is facing the board.</p> <p>Check/replace battery.</p> <p>If using an external power supply, check that the correct connections have been made. <i>(Ensure the battery has been removed)</i></p>
LED(s) stuck on	<p>After changing AKS Jumper position, turn power off, then on again.</p> <p>After replacing the E1103 Keyboard, turn the power off, then on again.</p>
AKS Mode unchanged after changing Jumper position	<p>Turn power off, then on again.</p>
Incorrect LED(s) light when keys touched	<p>Check J2 connector pins on E1103 Main PCB and E1103 Keyboard are correctly aligned.</p>

E1103 Kit Contents:

1x E1103 Evaluation Assembly (E1103 Main PCB and E1103 Keyboard PCB)			
1x CR2032 Battery, 3V, 235mAh			
2x sample QT1103-ISG ICs			
1x E1103 User Guide			
<i>Packed by:</i>		<i>Dated:</i>	

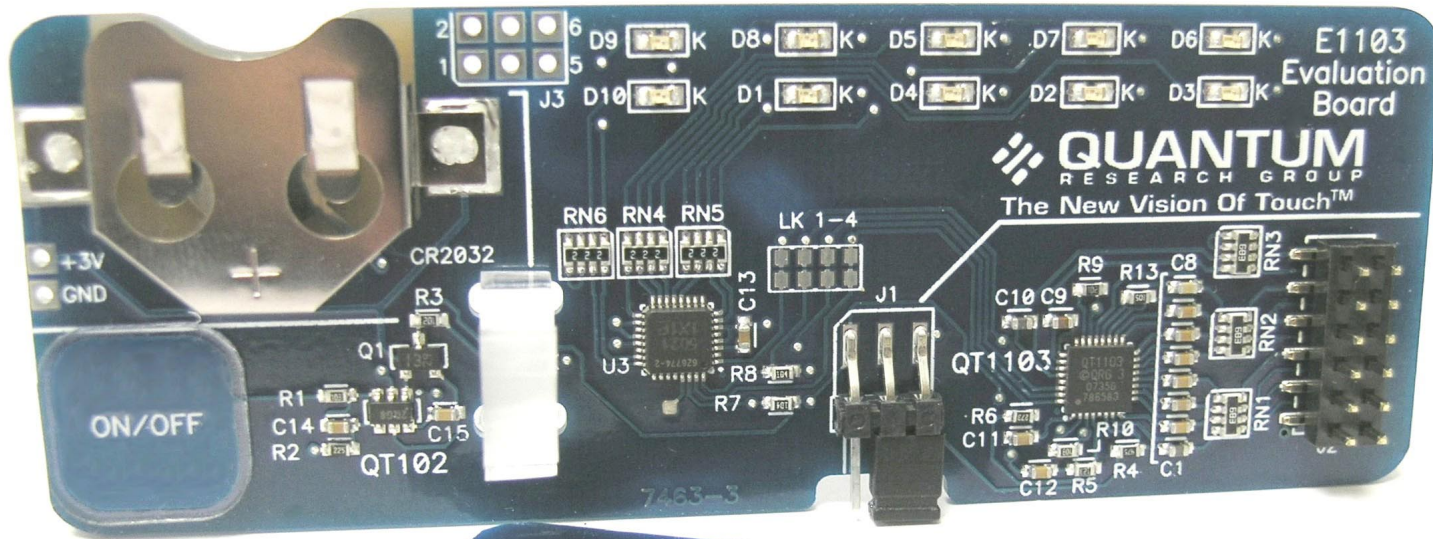

Corporate Headquarters:

1 Mitchell Point
 Ensign Way, Hamble
 Southampton SO31 4RF
 United Kingdom
 Tel:+44 (0)23 8056 5600
 Fax:+44 (0)23 8045 3939

North America:

651 Holiday Drive Bldg 5/300
 Pittsburgh, PA 15220
 USA
 Tel:412-391-7367
 Fax:412-291-1015

Developers:

John Dubery, Kevin Snoad

Copyright © 2007-2008 QRG Ltd.
 All rights reserved
 Patented and patents pending
www.qprox.com
 REV 201.0108

