Features

- Reference Oscillator up to 15 MHz
- Two Programmable 16-bit Dividers Adjustable from 2 to 65535
- Fine Tuning Steps
 - AM ≥ 1 kHz
 - FM ≥ 2 kHz
- Four Programmable Switching Outputs (Open Drain up to 15V)
- Integrated Loop-push-pull Stage for AM/FM
- High Signal/Noise Ratio



AM/FM PLL with 4 Switches

ATR4285

1. Description

The ATR4285 is an integrated circuit in BiCMOS technology for frequency synthesizers. It performs all the functions of a PLL radio tuning system and is controlled by a 2-wire bus. The device is designed for all frequency synthesizer applications in radio receivers, as well as for RDS (Radio Data System) applications.



Figure 1-1. Block Diagram

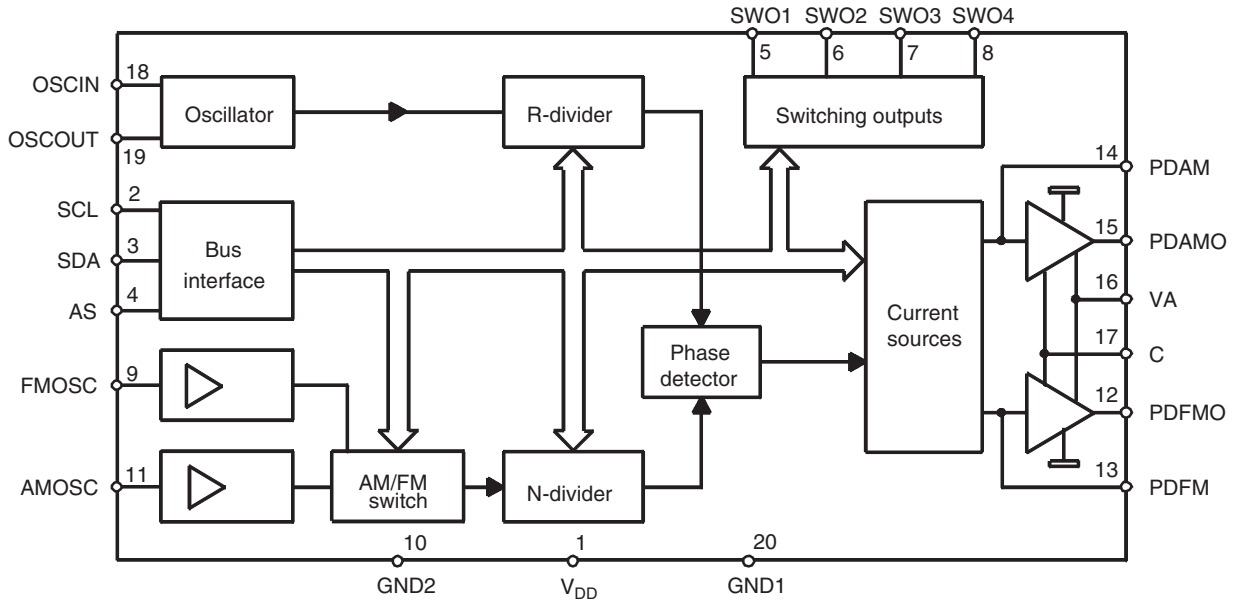

2. Pin Configuration

Figure 2-1. Pinning SSO20

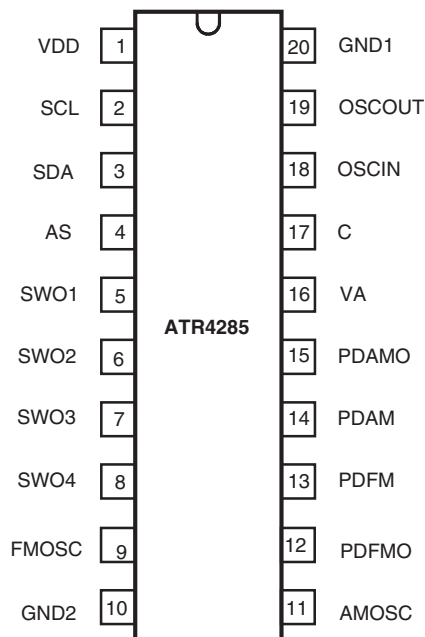

Table 2-1. Pin Description

Pin	Symbol	Function
1	VDD	Supply voltage
2	SCL	Bus clock
3	SDA	Bus data
4	AS	Address selection
5	SWO1	Switching output 1
6	SWO2	Switching output 2
7	SWO3	Switching output 3
8	SWO4	Switching output 4
9	FMOSC	FM oscillator input
10	GND2	Ground 2 (analog)
11	AMOSC	AM oscillator input
12	PDFMO	FM analog output
13	PDFM	FM current output
14	PDAM	AM current output
15	PDAMO	AM analog output
16	VA	Analog supply voltage
17	C	Capacitor
18	OSCIN	Oscillator input
19	OSCOUT	Oscillator output
20	GND1	Ground 1 (digital)

3. Functional Description

The ATR4285 is controlled via the 2-wire bus. One module-address byte, two subaddress bytes, and five data bytes enable programming.

The module address contains a programmable address bit A1, which (along with address select input AS, pin 4) enables the operation of two ATR4285 devices in one system. If bit A1 is identical with the status of the address select input AS, the chip is selected.

The subaddress determines which of the data bytes is transmitted first. If the subaddress of the R-divider is transmitted, the sequence of the next data bytes is DB 0 (status), DB 1 and DB 2. If the subaddress of the N-divider is transmitted, the sequence of the next data bytes is DB 3 and DB 4. The bit organization of the module address, subaddress and data bytes is shown in Table [“Bit Organization” on page 9](#).

Each transmission on the bus begins with the "START" condition and must be ended by the "STOP" condition (see Table [“Transmission Protocol” on page 9](#)).

The integrated circuit ATR4285 has two separate inputs for the AM and FM oscillators. Pre-amplified AM and FM signals are fed to the 16-bit N-divider via the AM/FM switch. The AM/FM switch is software controlled. Tuning steps can be selected by the 16-bit R-divider.

Furthermore, the device provides a digital memory phase detector and two separate current sources for AM and FM amplifiers (charge pump) as given in the Table [“Electrical Characteristics” on page 5](#). The separate current sources (charge pumps) allow independent gain adjustment, providing high current for high-speed tuning and low current for stable tuning.

4. Absolute Maximum Ratings

Stresses beyond those listed under “Absolute Maximum Ratings” may cause permanent damage to the device. This is a stress rating only and functional operation of the device at these or any other conditions beyond those indicated in the operational sections of this specification is not implied. Exposure to absolute maximum rating conditions for extended periods may affect device reliability.

Parameters	Pins	Symbol	Value	Unit
Supply voltage	1	V_{DD}	-0.3 to +6	V
Input voltage	2, 3, 4, 9, 11, 18, 19	V_I	-0.3 to $V_{DD} + 0.3$	V
Output current	3, 5, 6, 7, 8	I_O	-1 to +5	mA
Output drain voltage	5, 6, 7, 8	V_{OD}	15	V
Analog supply voltage with 220 Ω serial resistance 2 minutes ⁽¹⁾	16	V_A V_A	6 to 15 24	V V
Output current	12, 15	I_{AO}	-1 to +20	mA
Ambient temperature range		T_{amb}	-30 to +85	°C
Storage temperature range		T_{stg}	-40 to +125	°C
Junction temperature		T_j	125	°C
Electrostatic handling (modified MIL STD 883 D method 3015.7: all supply pins connected together)		$\pm V_{ESD}$	1000	V

Note: 1. Corresponding to the application circuit (Figure 9-1 on page 10)

5. Thermal Resistance

Parameters	Symbol	Value	Unit
Junction ambient	R_{thJA}	160	K/W

6. Electrical Characteristics

$V_{DD} = 5V$, $V_A = 10V$, $T_{amb} = 25^\circ C$, unless otherwise specified

Parameters	Test Conditions	Pins	Symbol	Min.	Typ.	Max.	Unit
Supply voltage		1	V_{DD}	4.5	5.0	5.5	V
Quiescent supply current	AM mode/FM mode	1	I_{DD}		4.0	7.0	mA
FM input sensitivity, $R_G = 50\Omega$, FMOSC	$f_i = 70$ MHz to 120 MHz	9	V_{SFM}	40			mV _{rms}
	$f_i = 160$ MHz	9	V_{SFM}	150			mV _{rms}
AM input sensitivity, $R_G = 50\Omega$, AMOSC	$f_i = 0.6$ MHz to 35 MHz	11	V_{SAM}	40			mV _{rms}
Oscillator input sensitivity, $R_G = 50\Omega$, OSCIN	$f_i = 0.1$ MHz to 15 MHz	18	V_{SOSC}	100			mV _{rms}
Switching Output SWO1, SWO2, SWO3, SWO4 (Open Drain)							
Output voltage LOW	$I_L = 1$ mA	5, 6, 7, 8	V_{SWOL}		100	400	mA
Output leakage current HIGH	V5, V6, V7, V8 = 10V	5, 6, 7, 8	I_{OHL}			100	nA
Phase Detector PDFM							
Output current 1		13	$\pm I_{PDFM}$	1600	2000	2400	μA
Output current 2		13	$\pm I_{PDFM}$	400	500	600	μA

6. Electrical Characteristics (Continued)

$V_{DD} = 5V$, $V_A = 10V$, $T_{amb} = 25^\circ C$, unless otherwise specified

Parameters	Test Conditions	Pins	Symbol	Min.	Typ.	Max.	Unit
Leakage current		13	$\pm I_{PDFML}$			20	nA
Phase Detector PDAM							
Output current 1		14	$\pm I_{PDAM}$	160	200	240	μA
Output current 2		14	$\pm I_{PDAM}$	40	50	60	μA
Leakage current		14	$\pm I_{PDAML}$			20	μA
Analog Output PDFMO, PDAMO							
Saturation voltage LOW	$I = 15\text{ mA}$	12, 15	V_{satL}		200	400	mW
Saturation voltage HIGH	$I = 15\text{ mA}$	12, 15	V_{satH}	9.5	9.95		V
Bus SCL, SDA, AS							
Input voltage HIGH		2, 3, 4	V_{IBUS}	3.0		V_{DD}	V
Input voltage LOW		2, 3, 4	V_{IBUS}	0		1.5	V
Output voltage acknowledge LOW	$I_{SDA} = 3\text{ mA}$	3	V_O			0.4	V
Clock frequency		2	f_{SCL}			100	kHz
Rise time SDA, SCL		2, 3	t_r			1	μs
Fall time SDA, SCL		2, 3	t_f			300	ns
Period of SCL HIGH	HIGH	2	t_H	4.0			μs
Period of SCL LOW	LOW	2	t_L	4.7			μs
Set-up Time							
Start condition			t_{sSTA}	4.7			μs
Data			t_{sDAT}	250			μs
Stop condition			t_{sSTOP}	4.7			μs
Time space ⁽¹⁾			t_{wSTA}	4.7			μs
Hold Time							
Start condition			t_{hSTA}	4.0			μs
Data			t_{hDAT}	0			μs

Note: 1. This is a period of time where the bus must be free from data transmission before a new transmission can be started.

Figure 6-1. FM Input Sensitivity, T = 85°C

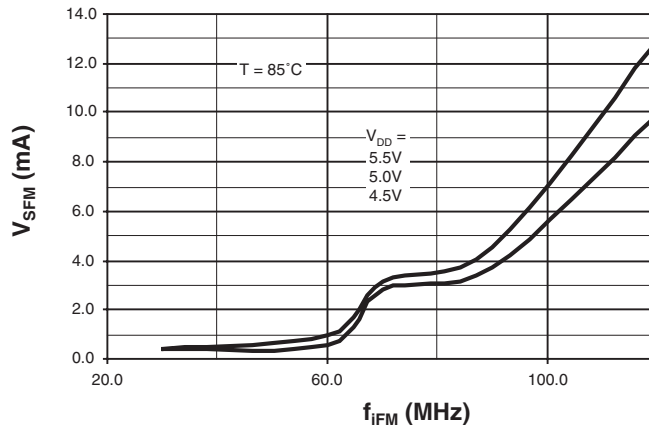

Figure 6-2. FM Input Sensitivity, T = -30°C

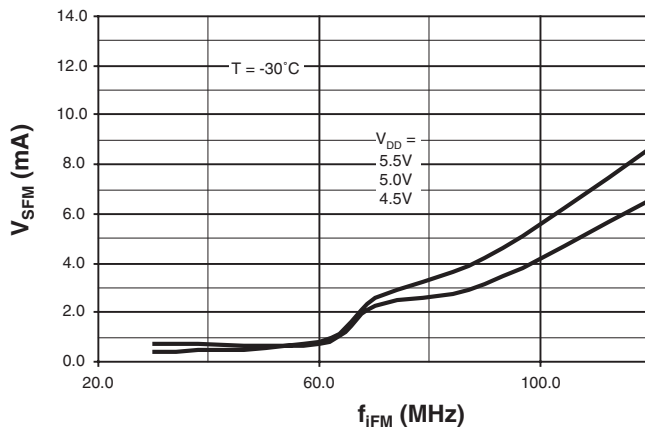

Figure 6-3. AM Input Sensitivity, T = 85°C

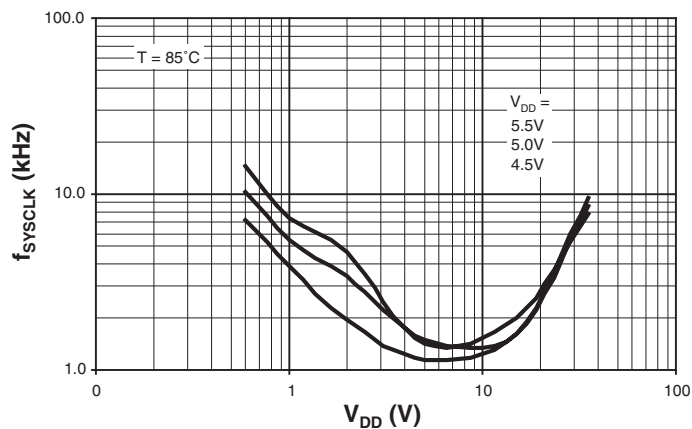

Figure 6-4. AM Input Sensitivity, $T = -30^{\circ}\text{C}$

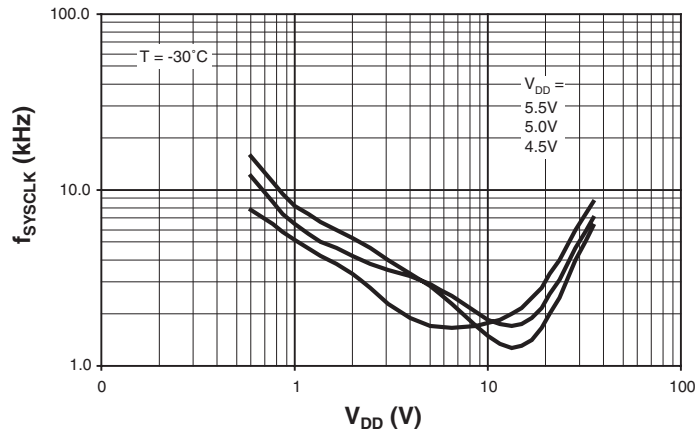
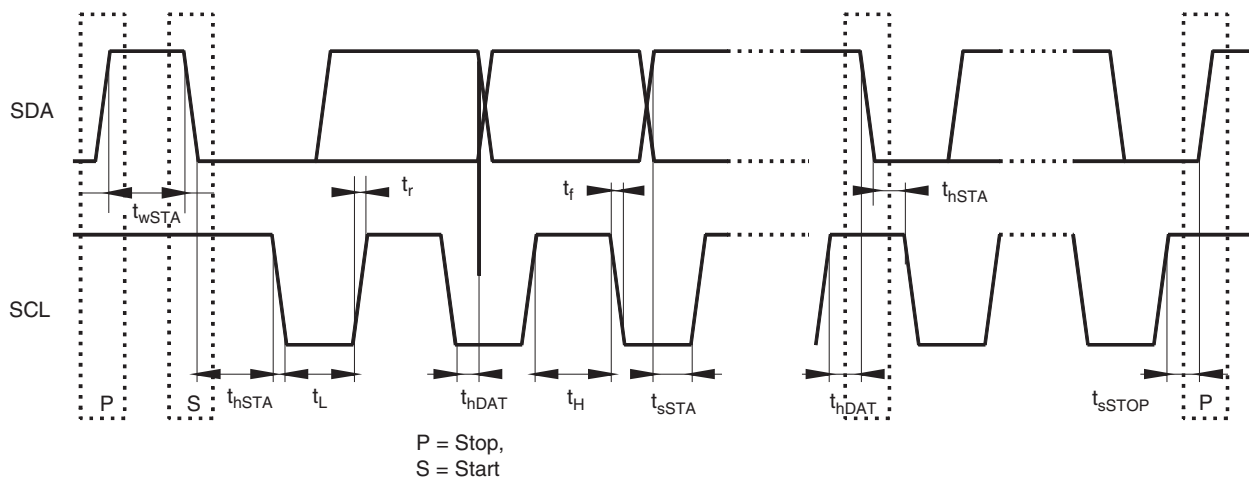

Figure 6-5. Bus Timing



7. Bit Organization

Table 7-1. Bit Organization

	MSB							LSB
Module address	1	1	0	0	1	0	0/1	0
	A7	A6	A5	A4	A3	A2	A1	A0
Subaddress (R-divider)	X	X	X	0	0	1	X	X
Subaddress (N-divider)	X	X	X	X	1	1	X	X
Data byte 0 (Status)	SWO1	SWO2	SWO3	SWO4	AM/FM	PD - ANA	PD - POL	PD - CUR
	D7	D6	D5	D4	D3	D2	D1	D0
Data byte 1	2^{15}	R-divider						2^8
Data byte 2	2^7	R-divider						2^0
Data byte 3	2^{15}	N-divider						2^8
Data byte 4	2^7	N-divider						2^0

Table 7-2. Function Mode

Bit Description	Mode	LOW	HIGH
D3	AM/FM	FM operation	AM operation
D2	PD - ANA	PD analog	Test
D1	PD - POL	Negative polarity	Positive polarity
D0	PD - CUR	Output current 2	Output current 1

8. Transmission Protocol

	MSB	LSB										
S	Address		A	Subaddress	A	Data 0	A	Data 1	A	Data 2	A	P
	A0	A7		R-divider								

	MSB	LSB									
S	Address		A	Subaddress	A	Data 3	A	Data 4	A	P	
	A0	A7		N-divider							

Note: S = Start, P = Stop, A = Acknowledge

9. Application

Figure 9-1. Application Circuit

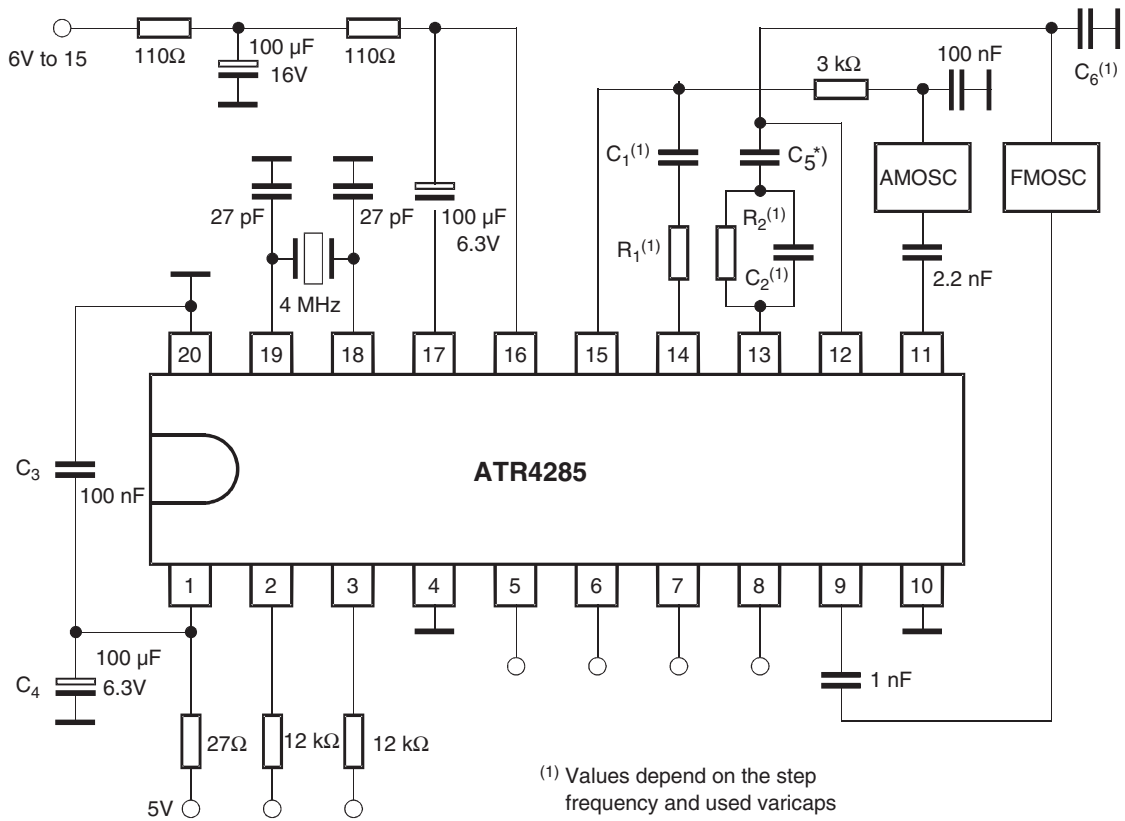

9.1 Recommendations for Applications

- $C_3 = 100\text{ nF}$ should be very close to pin 1 (V_{DD}) and pin 20 (GND 1)
- GND 2 (pin 10 — analog ground) and GND 1 (pin 20 — digital ground) must be connected according to [Figure 9-1](#)
- 4 MHz crystal must be very close to pin 18 and pin 19
- Components of the charge pump (C_1/R_1 for AM and C_2/R_2 for FM) should be very close to pin 14 with respect to pin 13

Figure 9-2. PCB Layout

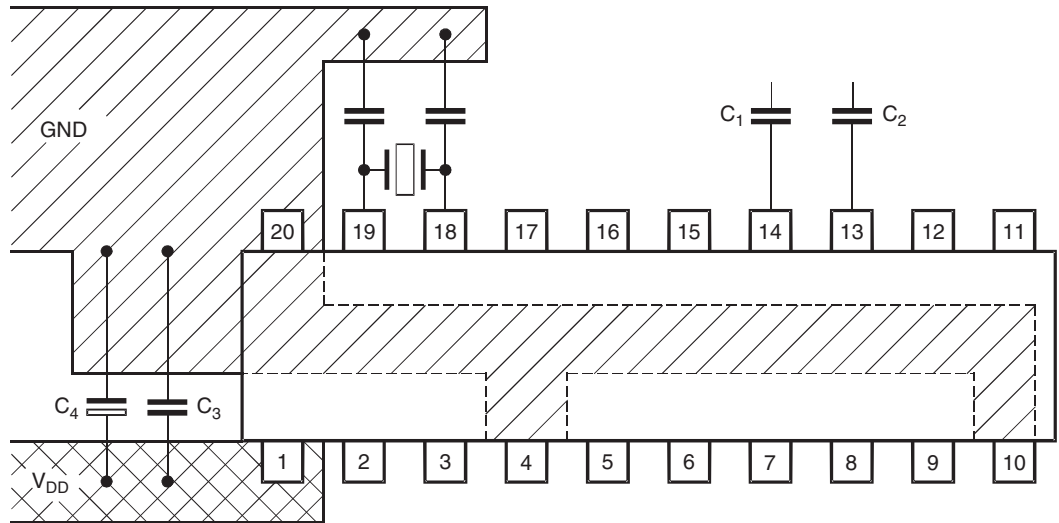

10. Ordering Information

Extended Type Number	Package	Remarks
ATR4285-TKSY	SSO20 plastic	Pb-free
ATR4285-TKQY	SSO20 plastic	Taping according to IEC-286-3, Pb-free

11. Package Information

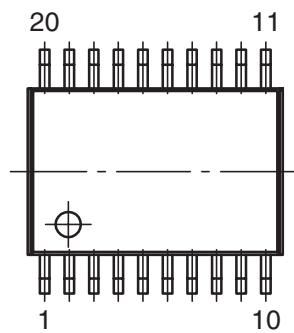
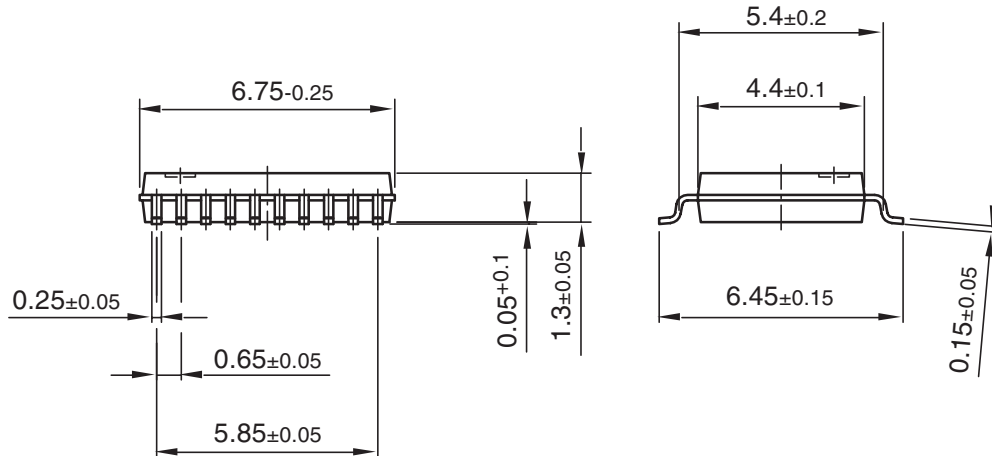

Package: SSO20
Dimensions in mm

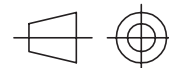

technical drawings
according to DIN
specifications

Drawing-No.: 6.543-5056.01-4

Issue: 1; 10.03.04



Atmel Corporation

2325 Orchard Parkway
San Jose, CA 95131, USA
Tel: 1(408) 441-0311
Fax: 1(408) 487-2600

Regional Headquarters

Europe

Atmel Sarl
Route des Arsenaux 41
Case Postale 80
CH-1705 Fribourg
Switzerland
Tel: (41) 26-426-5555
Fax: (41) 26-426-5500

Asia

Room 1219
Chinachem Golden Plaza
77 Mody Road Tsimshatsui
East Kowloon
Hong Kong
Tel: (852) 2721-9778
Fax: (852) 2722-1369

Japan

9F, Tonetsu Shinkawa Bldg.
1-24-8 Shinkawa
Chuo-ku, Tokyo 104-0033
Japan
Tel: (81) 3-3523-3551
Fax: (81) 3-3523-7581

Atmel Operations

Memory

2325 Orchard Parkway
San Jose, CA 95131, USA
Tel: 1(408) 441-0311
Fax: 1(408) 436-4314

Microcontrollers

2325 Orchard Parkway
San Jose, CA 95131, USA
Tel: 1(408) 441-0311
Fax: 1(408) 436-4314

La Chantrerie
BP 70602
44306 Nantes Cedex 3, France
Tel: (33) 2-40-18-18-18
Fax: (33) 2-40-18-19-60

ASIC/ASSP/Smart Cards

Zone Industrielle
13106 Rousset Cedex, France
Tel: (33) 4-42-53-60-00
Fax: (33) 4-42-53-60-01

1150 East Cheyenne Mtn. Blvd.
Colorado Springs, CO 80906, USA
Tel: 1(719) 576-3300
Fax: 1(719) 540-1759

Scottish Enterprise Technology Park
Maxwell Building
East Kilbride G75 0QR, Scotland
Tel: (44) 1355-803-000
Fax: (44) 1355-242-743

RF/Automotive

Theresienstrasse 2
Postfach 3535
74025 Heilbronn, Germany
Tel: (49) 71-31-67-0
Fax: (49) 71-31-67-2340

1150 East Cheyenne Mtn. Blvd.
Colorado Springs, CO 80906, USA
Tel: 1(719) 576-3300
Fax: 1(719) 540-1759

Biometrics/Imaging/Hi-Rel MPU/ High Speed Converters/RF Datacom

Avenue de Rochepleine
BP 123
38521 Saint-Egreve Cedex, France
Tel: (33) 4-76-58-30-00
Fax: (33) 4-76-58-34-80

Literature Requests

www.atmel.com/literature

Disclaimer: The information in this document is provided in connection with Atmel products. No license, express or implied, by estoppel or otherwise, to any intellectual property right is granted by this document or in connection with the sale of Atmel products. **EXCEPT AS SET FORTH IN ATMEL'S TERMS AND CONDITIONS OF SALE LOCATED ON ATMEL'S WEB SITE, ATMEL ASSUMES NO LIABILITY WHATSOEVER AND DISCLAIMS ANY EXPRESS, IMPLIED OR STATUTORY WARRANTY RELATING TO ITS PRODUCTS INCLUDING, BUT NOT LIMITED TO, THE IMPLIED WARRANTY OF MERCHANTABILITY, FITNESS FOR A PARTICULAR PURPOSE, OR NON-INFRINGEMENT. IN NO EVENT SHALL ATMEL BE LIABLE FOR ANY DIRECT, INDIRECT, CONSEQUENTIAL, PUNITIVE, SPECIAL OR INCIDENTAL DAMAGES (INCLUDING, WITHOUT LIMITATION, DAMAGES FOR LOSS OF PROFITS, BUSINESS INTERRUPTION, OR LOSS OF INFORMATION) ARISING OUT OF THE USE OR INABILITY TO USE THIS DOCUMENT, EVEN IF ATMEL HAS BEEN ADVISED OF THE POSSIBILITY OF SUCH DAMAGES.** Atmel makes no representations or warranties with respect to the accuracy or completeness of the contents of this document and reserves the right to make changes to specifications and product descriptions at any time without notice. Atmel does not make any commitment to update the information contained herein. Unless specifically provided otherwise, Atmel products are not suitable for, and shall not be used in, automotive applications. Atmel's products are not intended, authorized, or warranted for use as components in applications intended to support or sustain life.

© Atmel Corporation 2005. All rights reserved. Atmel®, logo and combinations thereof, Everywhere You Are® and others, are registered trademarks or trademarks of Atmel Corporation or its subsidiaries. Other terms and product names may be trademarks of others.



Printed on recycled paper.

4884A-AUDR-08/05