

Features

- World Tuner Application Due to Integrated VCO Dividers
- RF Input for Weather Band Applications
- AM Reception 100 kHz Up to 30 MHz
- AM Up/Down Conversion Depending on Reception Frequency
- VCO Slave Mode for Phase Diversity Applications
- FM Image Rejection Mixer
- Selectable High-side/Low-side Injection for FM Mode
- Selectable FM Mixer Output
- RF-AGC Wideband Threshold Programmable for AM and FM
- RF-AGC Inband Threshold Programmable
- Cascode Control Voltage for AM FET Pre-stage
- Integrated Pin-diode Drivers for AM and FM
- Three Selectable IF Amplifier Inputs
- Fractional PLL with Fast Lock Time
- Small Frequency Steps for AM
- Excellent SNR for DRM Applications
- Differential Reference Frequency Input for PLL Down to 9 kHz or Integrated XCO Driver Available
- Two Wire Interface (TWI) with Two Selectable Bus Addresses
- Digital Electronic Alignment of Up to Two External Filter Stages
- Flexible and Economic IF Filter Concept
- Control Inputs for IF Gain, Reception Frequency and Keyed AGC
- Integrated State-machine for Optional Control of Alternative Frequency Check
- Only One Power Supply Voltage Necessary

1. Description

The ATR4262M1 is a single-chip AM/FM and weather band tuner dedicated for digital IF solutions in car-radio applications. ATR4262M1 is produced using Atmel®'s advanced BICMOS2S technology and fulfills the automotive requirements. This part is suitable for HD Radio™ reception as well as for DRM solutions. The high flexibility allows to design high performance and cost optimized tuner solutions.



Broadcast Radio Front-end IC for AM/FM/DRM/HD Radio

ATR4262M1

Summary

Preliminary

NOTE: This is a summary document. The complete document is available under NDA. For more information, please contact your local Atmel sales office.

4994BS-AUDR-05/08



2. Pin Configuration

Figure 2-1. Pinning QFN48

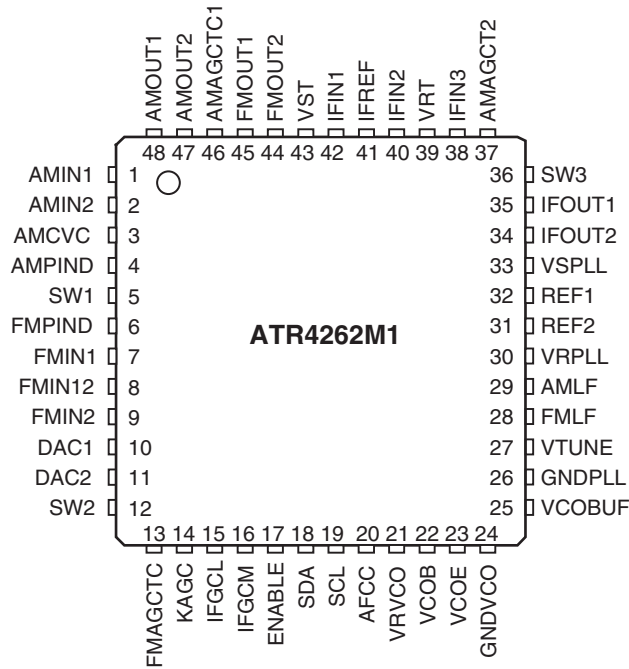

Table 2-1. Pin Description

Pin	Symbol	Function
1	AMIN1	AM mixer input
2	AMIN2	AM mixer input
3	AMVCV	AM cascode voltage output
4	AMPIND	AM pin diode output
5	SW1	SW1 switching output
6	FMPIND	FM pin diode output
7	FMIN1	FM mixer input 1
8	FMIN12	FM mixer input 12
9	FMIN2	FM mixer input 2
10	DAC1	DAC tuning voltage output 1
11	DAC2	DAC tuning voltage output 2
12	SW2	SW2 switching output/external tuning voltage input
13	FMAGCTC	RF AGC FM time constant
14	KAGC	Keyed AGC input/SW7/lock detect/AFSAMPLE
15	IFGCL	IF gain control LSB/SW4
16	IFGCM	IF gain control MSB/SW5
17	ENABLE	Control bus ENABLE/address select
18	SDA	Two-wire control bus SDA
19	SCL	Two-wire control bus SCL

Table 2-1. Pin Description

Pin	Symbol	Function
20	AFCC	AFC control input/SW6 switching output/lock detect/AFHOLD
21	VRVCO	Reference voltage VCO
22	VCOB	VCO resonator (base)
23	VCOE	VCO resonator (emitter)
24	GNDVCO	VCO ground
25	VCOBUF	VCO buffer output/input
26	GNDPLL	PLL ground
27	VTUNE	Tuning voltage output
28	FMLF	PLL loopfilter FM
29	AMLF	PLL loopfilter AM
30	VRPLL	Reference voltage digital
31	REF2	RefClockInput2/crystal oscillator
32	REF1	RefClockInput1/crystal oscillator
33	VSPLL	Supply voltage digital input
34	IFOUT2	IF output 2
35	IFOUT1	IF output 1
36	SW3	SW3 switching output/lock detect/AFSAMPLE
37	AMAGCTC2	RF AGC AM time constant 2
38	IFIN3	IF amplifier input
39	VRT	Reference voltage tuner
40	IFIN2	IF amplifier input
41	IFREF	IF reference voltage
42	IFIN1	IF amplifier input
43	VST	Supply voltage tuner
44	FMOUT2	FM mixer output
45	FMOUT1	FM mixer output
46	AMAGCTC1	RF AGC AM time constant 1
47	AMOUT2	AM mixer output/FM Mixer Output 4
48	AMOUT1	AM mixer output/FM Mixer Output 3
Die pad	GNDT_PAD	Tuner RF and IF Ground

3. Absolute Maximum Ratings

Stresses beyond those listed under “Absolute Maximum Ratings” may cause permanent damage to the device. This is a stress rating only and functional operation of the device at these or any other conditions beyond those indicated in the operational sections of this specification is not implied. Exposure to absolute maximum rating conditions for extended periods may affect device reliability.

Parameters	Pin Group	Min.	Max.	Unit
Voltage	Digital	-0.5	+5.5	V
	Supply	-0.5	+12	V
	Voltage references	-0.5	+6.4	V
	SW1, SW3	-0.5	+12	V
	SW2	-0.5	$V_S + 0.5$	V
	SW4, SW5, SW6, SW7	-0.5	+ 5.5	V
	Mixer outputs	-0.5	+16	V
	Analog	-0.5	$V_S + 0.5$	V
Current	Switches	0	2.7	mA
Ambient temperature	T_{amb}	-40	+100	°C
Storage temperature	T_{stg}	-40	+100	°C
Junction temperature	T_j		+150	°C
Power dissipation	P_{tot}		1.4	W
ESD HBM	All pins	-2	+2	kV
ESD MM	All pins	-200	+200	V

4. Thermal Resistance

Parameters	Test Condition	Symbol	Value	Unit
Thermal resistance junction-ambient	Soldered to PCB	R_{thJA}	30	K/W

5. Operating Range

Parameters	Symbol	Value	Unit
Supply voltage	V_S	8 to 10	V
Supply voltage for operation of control bus (data preservation in bus registers is guaranteed)	V_S	7 to 10	V
Ambient temperature	T_{amb}	-40 to +90	°C

6. Functional Description

The ATR4262M1 front end is designed for world-tuner applications. Due to its flexible divider arrangement, the tuner can be used for reception from 100 kHz to 163 MHz. The field of use covers all the common radio broadcast services from AM-LW to AM-SW (up to 30 MHz) and from FM-OIRT to US weatherband. The tuner application can be easily adapted to the requirements of DRM and HD-radio (IBOC).

- FM section

The ATR4262M1 contains a high performance FM image rejection mixer, which helps to reduce the demands and the cost of the front end application. The FM mixer output can be switched to an alternative pair of pins to allow different IF filter concepts for FM mode. Two selectable inputs can be used for independent FM front end sections.

- AM section

The AM section contains a dedicated AM prescaler for the LO signal. Very small tuning steps are possible using this divider, while at the same time a high PLL comparison frequency guarantees excellent phase noise behavior.

- RF-AGC

Both AM and FM signal paths have their own RFAGCs with a wideband and an inband detector with individual thresholds. The thresholds for AM and FM can be programmed in 2 dB steps. An optional keyed AGC function reduces the wideband AGC threshold up to 6 dB in order to avoid desensitization of the tuner. Pin diode drivers for AM and FM are integrated to reduce cost for external components. In addition to the pin diode control, a cascode control voltage for the external LNA is provided by the AM-AGC block.

- IF stage

The IF amplifier has three selectable inputs, which can be matched to any common IF filter impedance by external components. With these inputs, the tuner application can be easily adapted to different broadcast standards, while conventional standards are still possible. Gain can be set via pins or by setting bits, which makes the ATR4262M1 very versatile and easy to adapt to different baseband architectures.

- Fractional PLL

The ATR4262M1 contains a complete fractional PLL, which guarantees fast lock time, low phase noise and small tuning steps. A reference clock frequency from 9 kHz up to 21 MHz provided by, for example, baseband can be used. Alternatively the integrated XCO with standard crystals from 10 MHz to 21 MHz can be used as the reference for the PLL.

- Double tuner concept

Like phase diversity or background tuning, double-tuner applications are also possible. For phase diversity applications, the tuner can also operate in slave mode with a master tuner providing the VCO frequency for both tuners.

- Digital electronic alignment

Two independent gain and offset programmable DACs are available to tune the FM front end section. The PLL's tuning voltage is used as input for the DACs to ensure proper tracking to the reception frequency. In slave mode, the tuning voltage of a master tuner must be applied to a dedicated input pin.

- Alternative frequency check

An optional state machine can control the alternative frequency check sequence for some common basebands. This feature reduces the CPU load of the main controller because the statemachine outputs the signals with the correct timing for quality check and muting of the baseband.

- Switching outputs

Up to seven general-purposes open-drain switches are available to simplify the customer application.

- Two-wire control interface

The ATR4262 can be programmed via a fast-mode TWI bus interface. Two different IC addresses can be selected to allow two tuners at the same bus segment. Various programming bits allow unique flexibility of operation modes. A tuner status byte provides information about the receiving conditions and the PLL status.

- Package and power supply

The ATR4262 comes in a small outline QFN48 package to allow small and cost-effective tuner applications. A single 8V to 10V supply voltage is sufficient to operate the ATR4262 and to reduce the complexity of the customer application.

7. VCO and AM Prescaler Settings

Table 7-1 gives an example of the VCO divider and AM Prescaler settings and the reception frequencies.

Table 7-1. Typical VCO Divider, AM Prescaler Settings, and Reception Frequencies

Band	VCO-divider (D _{FM})	N-div. Prescaler (D _{PLL})	IF [MHz]	Min. Reception Frequency [MHz]	Max. Reception Frequency [MHz]	Min. VCO Frequency	Max. VCO Frequency	AM-Prescaler (D _{AM})
FM	2	2	+10.7	87.5	108	196.4	237.4	-
JPN	3	3	-10.7	76	90	195.9	237.9	-
WB	1	2	+10.7	162.4	162.55	173.1	173.25	-
OIRT	3	3	+10.7	65.8	74	229.5	254.1	-
OIRT	3	3	-10.7	65.8	74	165.3	189.9	-
LW/MW	-	2	+10.7	0.15	1.605	217	246.1	10
LW/MW	-	2	+10.7	0.15	1.605	195.3	221.49	9
120m	-	2	+10.7	2.3	2.5	208	211.2	8
...								
49m	-	2	+10.7	5.95	6.2	199.8	202.8	6
41m	-	2	+10.7	7.1	7.35	213.6	216.6	6
31m	-	2	+10.7	9.5	9.9	202	206	5
...								
15m	-	2	+10.7	21.45	21.85	192.9	195.3	3

A small VCO frequency range of e.g., 195.3 MHz to 237.9 MHz allows reception of the most important bands like FM, JPN, LW, MW, 49m, 41m, and 31m.

8. Power Supply

There is only one power supply voltage (8V to 10V) necessary for operation of the ATR4262M1.

9. IF Filter Stage Concept

There are several different IF filter concepts possible depending on the broadcast standard and the targeted quality range of the tuner. For that purpose a programmable switch for the FM mixer output as well as three programmable inputs for the IF amplifier is available.

Table 9-1. IF Filter Stage Configuration

Configuration	FMOUT	AMFMOUT	Number of Mixer Output Tanks	Number of IF Filters
AM low cost	Not used or connected to AMFMOUT	Mixer tank Ceramic filter (BW 180 kHz)	1	1
AM ceramic filter (compatible to DRM)	Mixer tank Ceramic filter (BW 180 kHz)	Mixer tank Ceramic filter (20 kHz)	2	2
AM crystal filter	Not used or connected to AMFMOUT	Mixer tank Ceramic filter (BW 180 kHz) Crystal filter (BW 7 kHz)	1	2
AM crystal filter, separate tank	Mixer tank Ceramic filter (BW 180 kHz)	Mixer tank Crystal filter (BW 7 kHz)	2	2
HD Radio	Mixer tank Ceramic filter (BW 400 kHz)	Mixer tank Ceramic filter (BW 180 kHz)	2	2
HD Radio low cost	Not used or connected to AMFMOUT	Mixer tank Ceramic filter (BW 400 kHz)	1	1
HD Radio with AM filter	Mixer tank Ceramic filter (BW 400 kHz)	Mixer tank Ceramic filter (BW 180 kHz) Ceramic filter (BW 30 kHz)	2	3

Figure 9-1. Example of Simple IF Filter Stage Concept

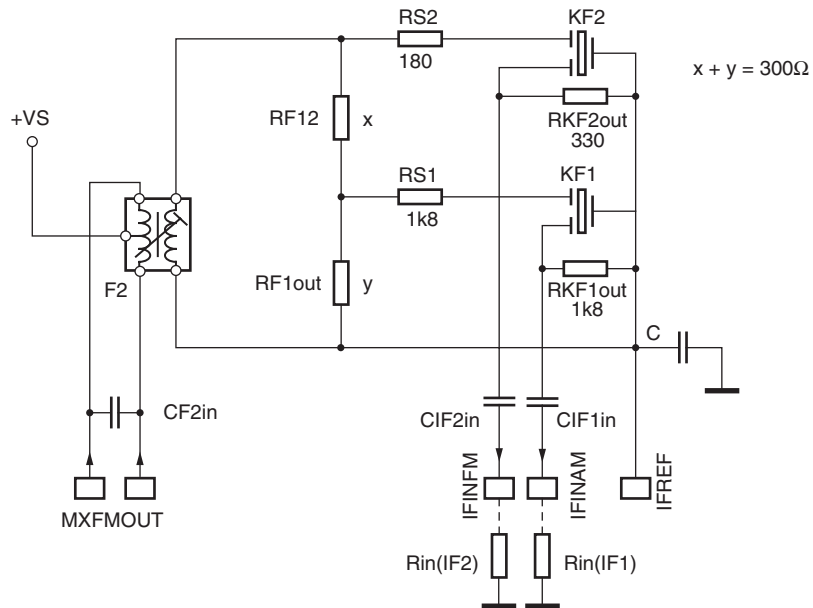

10. Double Tuner Application

Figure 10-1. Double Tuner Operation

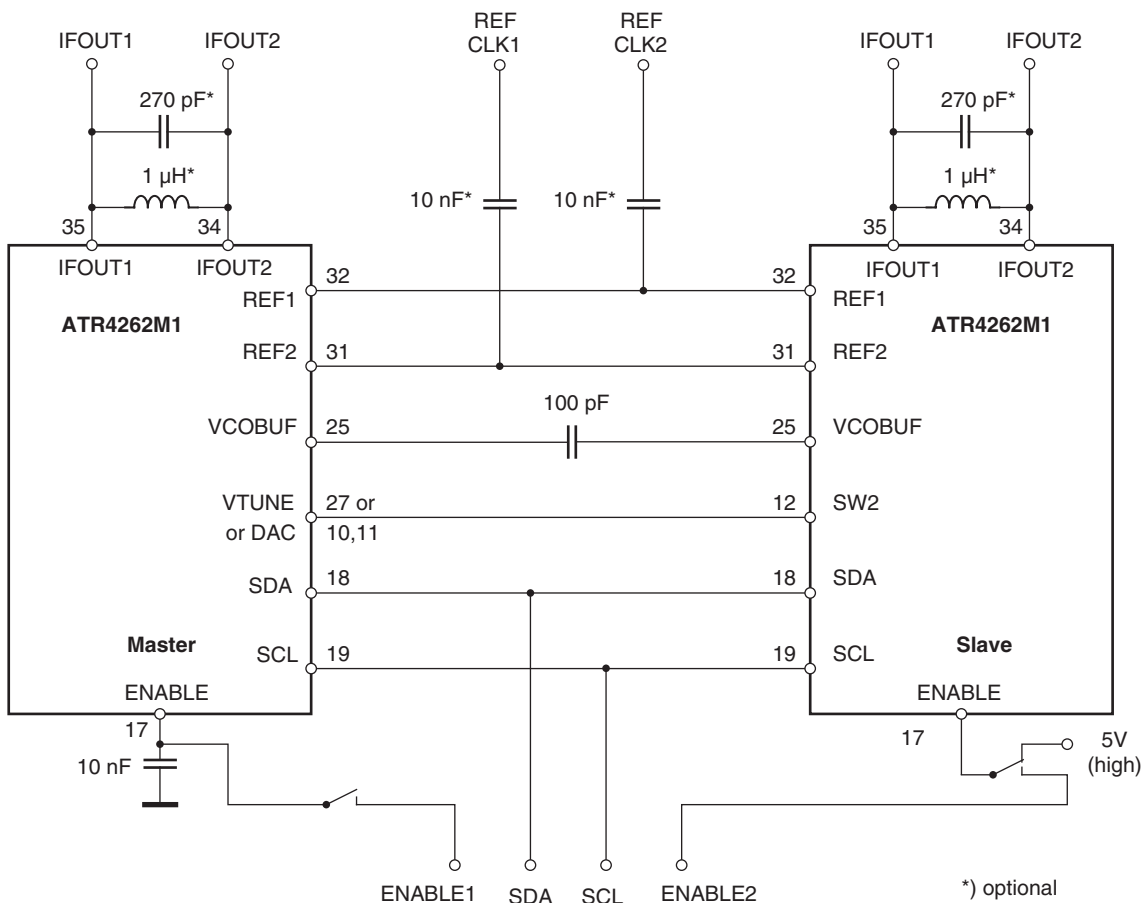

10.1 Two-Wire Interface-Bus Address Modes

To allow programming of both ICs (e.g., double tuner), SCL and SDA can be connected to both ICs.

There are two different modes for ENABLE. For example, the ENABLE pin of the master IC is not connected (open mode). Only a capacitor to ground is required to avoid oscillations of the ENABLE pin. To program the master IC for open mode, the address byte C2h must be used.

The ENABLE pin of the other IC (slave) has to be set to high. The applied voltage for high mode should be in the range of 2.5V to 5.3V. Address byte C0h is used as the slave in this case.

Another possibility is the use of separate ENABLE lines which can be controlled by a microcontroller.

11. Ordering Information

Extended Type Number	Package	Remarks
ATR4262M1-PLQW	QFN48 - 7 x 7	Taped and reeled

12. Package Information

Package: QFN 48 - 7 x 7
 Exposed pad 4.5 x 4.5
 (acc. JEDEC OUTLINE No. MO-220)
 Dimensions in mm

Not indicated tolerances ± 0.05

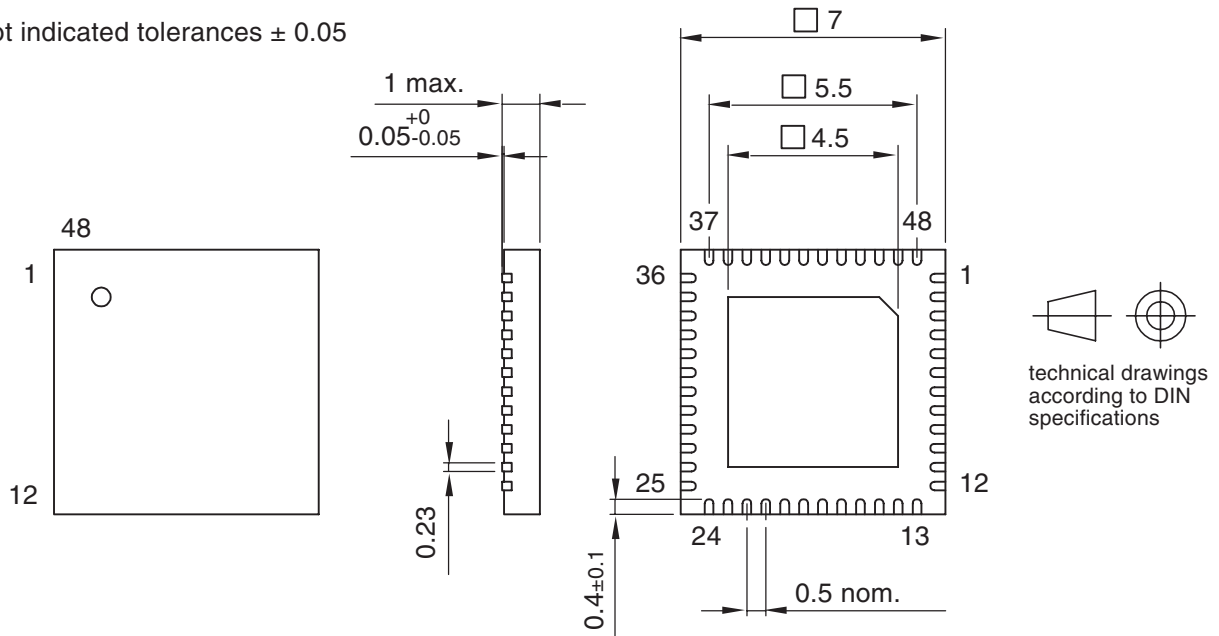

Drawing-No.: 6.543-5089.01-4

Issue: 2; 24.01.03

13. Revision History

Please note that the following page numbers referred to in this section refer to the specific revision mentioned, not to this document.

Revision No.	History
4994BS-AUDR-03/08	<ul style="list-style-type: none"> • all pages: Part Number changed in ATR4262M1 • all pages: IBOC changed in HD Radio • Page 1: Features changed • Page 4: Table Absolute Maximum Ratings changed • Page 5: narrowband replaced by inband • Page 7: Last row changed • Page 9: Heading 22.1 changed • Page 10: Ordering Information changed



Headquarters

Atmel Corporation
2325 Orchard Parkway
San Jose, CA 95131
USA
Tel: 1(408) 441-0311
Fax: 1(408) 487-2600

International

Atmel Asia
Room 1219
Chinachem Golden Plaza
77 Mody Road Tsimshatsui
East Kowloon
Hong Kong
Tel: (852) 2721-9778
Fax: (852) 2722-1369

Atmel Europe
Le Krebs
8, Rue Jean-Pierre Timbaud
BP 309
78054
Saint-Quentin-en-Yvelines Cedex
France
Tel: (33) 1-30-60-70-00
Fax: (33) 1-30-60-71-11

Atmel Japan
9F, Tonetsu Shinkawa Bldg.
1-24-8 Shinkawa
Chuo-ku, Tokyo 104-0033
Japan
Tel: (81) 3-3523-3551
Fax: (81) 3-3523-7581

Product Contact

Web Site
www.atmel.com

Technical Support
broadcast@atmel.com

Sales Contact
www.atmel.com/contacts

Literature Requests
www.atmel.com/literature

Disclaimer: The information in this document is provided in connection with Atmel products. No license, express or implied, by estoppel or otherwise, to any intellectual property right is granted by this document or in connection with the sale of Atmel products. **EXCEPT AS SET FORTH IN ATMEL'S TERMS AND CONDITIONS OF SALE LOCATED ON ATMEL'S WEB SITE, ATMEL ASSUMES NO LIABILITY WHATSOEVER AND DISCLAIMS ANY EXPRESS, IMPLIED OR STATUTORY WARRANTY RELATING TO ITS PRODUCTS INCLUDING, BUT NOT LIMITED TO, THE IMPLIED WARRANTY OF MERCHANTABILITY, FITNESS FOR A PARTICULAR PURPOSE, OR NON-INFRINGEMENT. IN NO EVENT SHALL ATMEL BE LIABLE FOR ANY DIRECT, INDIRECT, CONSEQUENTIAL, PUNITIVE, SPECIAL OR INCIDENTAL DAMAGES (INCLUDING, WITHOUT LIMITATION, DAMAGES FOR LOSS OF PROFITS, BUSINESS INTERRUPTION, OR LOSS OF INFORMATION) ARISING OUT OF THE USE OR INABILITY TO USE THIS DOCUMENT, EVEN IF ATMEL HAS BEEN ADVISED OF THE POSSIBILITY OF SUCH DAMAGES.** Atmel makes no representations or warranties with respect to the accuracy or completeness of the contents of this document and reserves the right to make changes to specifications and product descriptions at any time without notice. Atmel does not make any commitment to update the information contained herein. Unless specifically provided otherwise, Atmel products are not suitable for, and shall not be used in, automotive applications. Atmel's products are not intended, authorized, or warranted for use as components in applications intended to support or sustain life.

© 2008 Atmel Corporation. All rights reserved. Atmel®, logo and combinations thereof, and others are registered trademarks or trademarks of Atmel Corporation or its subsidiaries. Other terms and product names may be trademarks of others.