

## Features

- Three Selectable Outputs
- All Outputs Can Be Used Either for Standard (5V) or High Voltage (9V)
- Maximum Output Current at All Outputs Up to 150 mA
- On-chip Low-EMI RF Oscillator With Spread-spectrum Technology
- Control of 3 Different Swings Using 3 External Resistors
- Oscillator Frequency Range from 200 MHz to 500 MHz
- Maximum Oscillator Current Amplitude 100 mA<sub>pp</sub>
- On-chip High-gain Transimpedance (IV) Amplifier
- Small Green QFN24 4 mm × 4 mm Package

## Applications

- HD-DVD/DVD/CD ROM Drives
- Blu-ray/DVD/CD ROM Drives
- HD-DVD/DVD/CD Player
- Blu-ray/DVD/CD Player

## 1. Description

ATR0885 is a laser diode driver designed to operate three different grounded or floating laser diodes for reading CDs ( $\lambda = 780$  nm), DVDs ( $\lambda = 650$  nm), and HD-DVDs/Blu-ray ( $\lambda = 405$  nm). An on-chip, low-EMI RF oscillator is available to reduce laser mode hopping noise. The oscillator's current amplitude can be set independently for the three selectable outputs using three resistors (RSA, RSB, RSC). The frequency setting is common to all IOUT outputs via a single resistor (RF). A logic high level on the ENOSC pin enables the spread-spectrum RF oscillator. The ATR0885 also includes a fast-settling transimpedance amplifier. It is provided to interface between the front-end monitor photo diode and the adaptive laser diode power control circuit. The gain of the transimpedance amplifier can set independently for each of the three outputs using the resistors RTIA, RTIB and RTIC.



## 3-output Laser Driver for HD-DVD/Blu-ray/DVD/CD-ROM

ATR0885

Preliminary

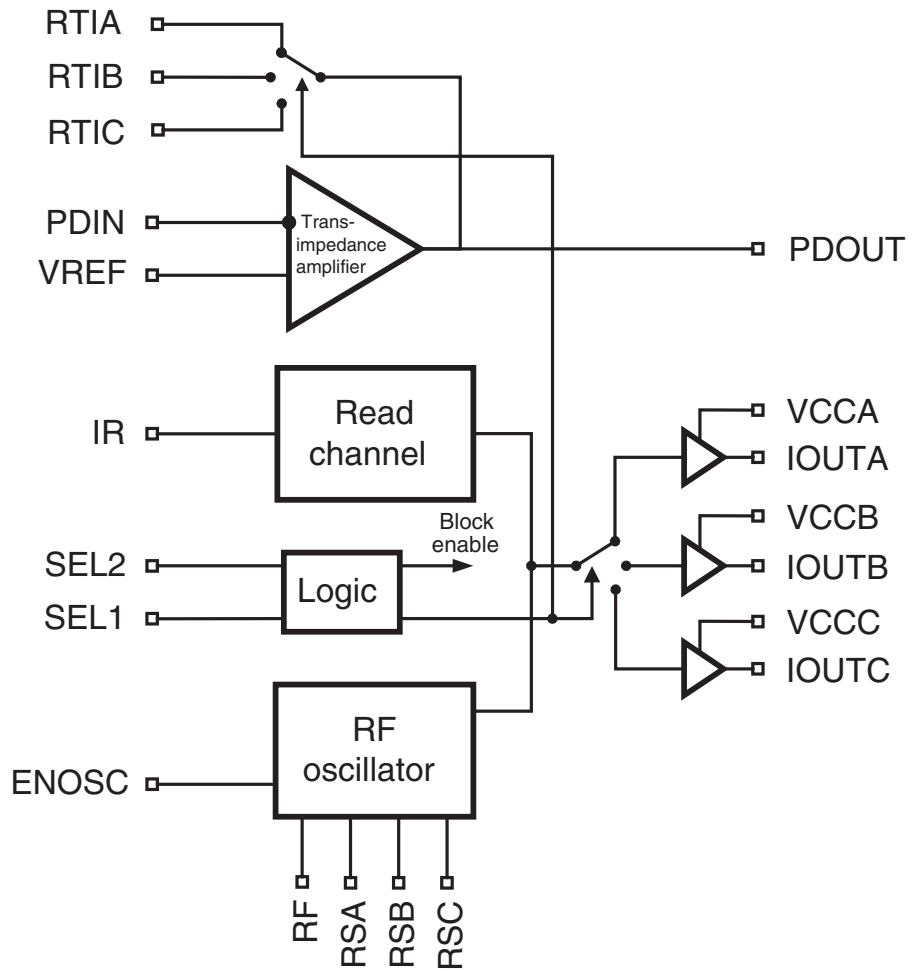
Summary

**NOTE:** This is a summary document. The complete document is available under NDA. For more information, please contact your local Atmel sales office.

4923CS-DVD-02/08

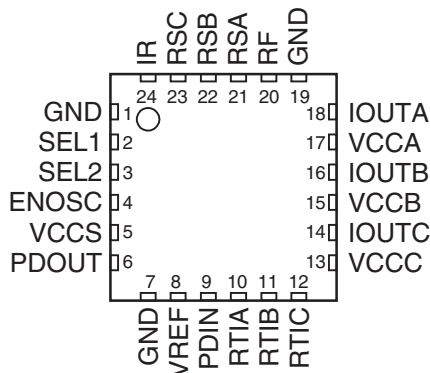


Figure 1-1. Block Diagram



## 2. Pin Configuration

**Figure 2-1.** Pinning QFN24



**Table 2-1.** Pin Description

Pin	Symbol	Type	Function
1	GND	Supply	Ground, power supply
2	SEL1	Digital	Logic pin 1 to select IOUT/ENABLE IC
3	SEL2	Digital	Logic pin 2 to select IOUT/ENABLE IC
4	ENOSC	Digital	Digital control of RF oscillator
5	VCCS	Supply	+5V power supply for internal circuit
6	PDOUT	Analog	IV amplifier output
7	GND	Supply	Ground, power supply
8	VREF	Analog	Reference voltage input
9	PDIN	Analog	Photo-diode input
10	RTIA	Analog	External resistor defining transimpedance IOUTA
11	RTIB	Analog	External resistor defining transimpedance IOUTB
12	RTIC	Analog	External resistor defining transimpedance IOUTC
13	VCCC	Supply	+5V to +9V power supply for IOUTC
14	IOUTC	Analog	Output current source C for laser diode
15	VCCB	Supply	+5V to +9V power supply for IOUTB
16	IOUTB	Analog	Output current source B for laser diode
17	VCCA	Supply	+5V to +9V power supply for IOUTA
18	IOUTA	Analog	Output current source A for laser diode
19	GND	Supply	Ground, power supply
20	RF	Analog	External resistor to GND; sets frequency of oscillator
21	RSA	Analog	External resistor to GND; sets swing of oscillator A
22	RSB	Analog	External resistor to GND; sets swing of oscillator B
23	RSC	Analog	External resistor to GND; sets swing of oscillator C
24	IR	Analog	Input current bias; ~500Ω to ground
Paddle	GND	Supply	-

### 3. Absolute Maximum Ratings

Stresses beyond those listed under “Absolute Maximum Ratings” may cause permanent damage to the device. This is a stress rating only and functional operation of the device at these or any other conditions beyond those indicated in the operational sections of this specification is not implied. Exposure to absolute maximum rating conditions for extended periods may affect device reliability.

Parameters	Pin	Symbol	Value	Unit
Supply voltage		$V_{VCCS}$	-0.5 to +6.0	V
Supply voltage output stages (VCCA, VCCB, VCCC)		$V_{VCCCH}$	-0.5 to +9.5	V
Input voltage		$V_{PDIN}$	-0.5 to $V_{CC}+0.5$	V
Differential voltage	8, 9	$V_{diff\_8,9}$	10.5I	V
Power dissipation		$P_{max}$	0.7 <sup>(1)</sup> to 1 <sup>(2)</sup>	W
Output voltage		$V_{out}$	-0.5 to $V_{cch}-1$	V
Junction temperature		$T_j$	150	°C
Storage temperature		$T_{stg}$	-65 to +125	°C

- Notes: 1.  $R_{thJA} \leq 115$  K/W at  $T_{amb} = 70^\circ\text{C}$   
 2.  $R_{thJA} \leq 115$  K/W at  $T_{amb} = 25^\circ\text{C}$

Electrostatic sensitive device.  
 Observe precautions for handling.



### 4. Thermal Resistance

Parameters	Symbol	Value	Unit
Junction ambient	$R_{thJA}$	50 <sup>(1)</sup>	K/W

- Note: 1. Measured with multi-layer test board (JDEC standard)

### 5. Recommended Operating Conditions

Parameters	Symbol	Value	Unit
Supply voltage	$V_{VCCS}$	4.5 to 5.5	V
High supply voltage (VCCA, VCCB, VCCC)	$V_{VCCCH}$	$V_{VCCS}$ to 9.0	V
Input current	$I_{IR}$	< 2	mA
Output voltage range	$V_{PDOUT}$	0.8 to ( $V_{VCCS} - 1.8$ )	V
External resistor to GND to set oscillator frequency	RF	> 3	k $\Omega$
External resistor to GND to set oscillator swing	RS1, RS2, RS3	> 100	$\Omega$
Operating temperature range	$T_{amb}$	0 to +70	°C
Transimpedance resistor	$R_{TI}$	1 to 50	k $\Omega$
Total capacitance at PDIN	$C_{PD}$	< 15	pF
Load resistance	$R_{Load}$	> 5	k $\Omega$
Load capacitance	$C_{Load}$	< 30	pF
Reference voltage	$V_{REF}$	1.6 to 3.0	V

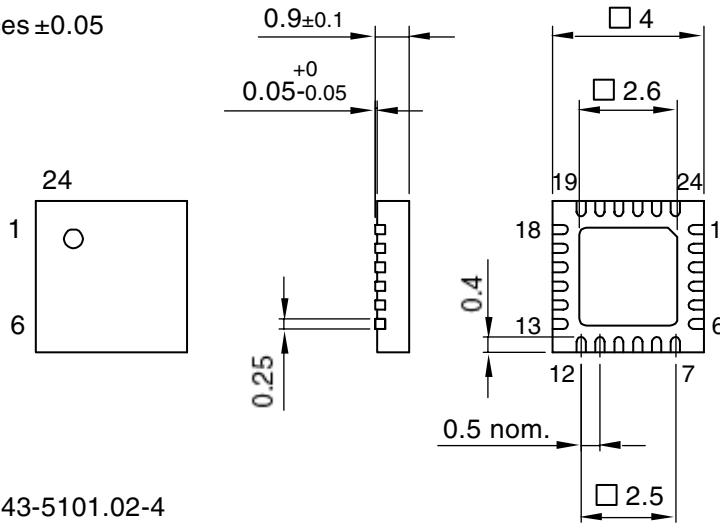
## 6. Ordering Information

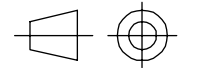
Extended Type Number	Package	Remarks
ATR0885-PFQW	Green QFN24 (4 mm × 4 mm)	Taped and reeled

## 7. Package Information

Package: QFN 24 - 4 x 4  
 Exposed pad 2.6 x 2.6  
 (acc. JEDEC OUTLINE No. MO - 220)  
 Dimensions in mm

Not indicated tolerances  $\pm 0.05$



  
 technical drawings  
 according to DIN  
 specifications

Drawing-No.: 6.543-5101.02-4  
 Issue: 1; 03.06.05

## 8. Revision History

Please note that the following page numbers referred to in this section refer to the specific revision mentioned, not to this document.

Revision No.	History
4923CC-DVD-02/08	<ul style="list-style-type: none"> <li>Put datasheet in a new template</li> <li>Pin Description table (page 3): Function of Pin 2 and 3 changed</li> </ul>



## Headquarters

---

**Atmel Corporation**  
2325 Orchard Parkway  
San Jose, CA 95131  
USA  
Tel: 1(408) 441-0311  
Fax: 1(408) 487-2600

## International

---

**Atmel Asia**  
Room 1219  
Chinachem Golden Plaza  
77 Mody Road Tsimshatsui  
East Kowloon  
Hong Kong  
Tel: (852) 2721-9778  
Fax: (852) 2722-1369

**Atmel Europe**  
Le Krebs  
8, Rue Jean-Pierre Timbaud  
BP 309  
78054  
Saint-Quentin-en-Yvelines Cedex  
France  
Tel: (33) 1-30-60-70-00  
Fax: (33) 1-30-60-71-11

**Atmel Japan**  
9F, Tonetsu Shinkawa Bldg.  
1-24-8 Shinkawa  
Chuo-ku, Tokyo 104-0033  
Japan  
Tel: (81) 3-3523-3551  
Fax: (81) 3-3523-7581

## Product Contact

---

**Web Site**  
[www.atmel.com](http://www.atmel.com)

**Technical Support**  
[dvd\\_1dd@atmel.com](mailto:dvd_1dd@atmel.com)

**Sales Contact**  
[www.atmel.com/contacts](http://www.atmel.com/contacts)

**Literature Requests**  
[www.atmel.com/literature](http://www.atmel.com/literature)

---

**Disclaimer:** The information in this document is provided in connection with Atmel products. No license, express or implied, by estoppel or otherwise, to any intellectual property right is granted by this document or in connection with the sale of Atmel products. **EXCEPT AS SET FORTH IN ATMEL'S TERMS AND CONDITIONS OF SALE LOCATED ON ATMEL'S WEB SITE, ATMEL ASSUMES NO LIABILITY WHATSOEVER AND DISCLAIMS ANY EXPRESS, IMPLIED OR STATUTORY WARRANTY RELATING TO ITS PRODUCTS INCLUDING, BUT NOT LIMITED TO, THE IMPLIED WARRANTY OF MERCHANTABILITY, FITNESS FOR A PARTICULAR PURPOSE, OR NON-INFRINGEMENT. IN NO EVENT SHALL ATMEL BE LIABLE FOR ANY DIRECT, INDIRECT, CONSEQUENTIAL, PUNITIVE, SPECIAL OR INCIDENTAL DAMAGES (INCLUDING, WITHOUT LIMITATION, DAMAGES FOR LOSS OF PROFITS, BUSINESS INTERRUPTION, OR LOSS OF INFORMATION) ARISING OUT OF THE USE OR INABILITY TO USE THIS DOCUMENT, EVEN IF ATMEL HAS BEEN ADVISED OF THE POSSIBILITY OF SUCH DAMAGES.** Atmel makes no representations or warranties with respect to the accuracy or completeness of the contents of this document and reserves the right to make changes to specifications and product descriptions at any time without notice. Atmel does not make any commitment to update the information contained herein. Unless specifically provided otherwise, Atmel products are not suitable for, and shall not be used in, automotive applications. Atmel's products are not intended, authorized, or warranted for use as components in applications intended to support or sustain life.

© 2008 Atmel Corporation. All rights reserved. Atmel®, logo and combinations thereof, and others are registered trademarks or trademarks of Atmel Corporation or its subsidiaries. Other terms and product names may be trademarks of others.