



Technical Data Sheet

Infrared Remote-control Receiver Module

IRM-36xx SERIES

Features

- High data rate (up to 4000 bit/sec)
- Standard protection ability against EMI .
- Circular lens to improve the receive characteristic.
- Line-up for various center carrier frequencies.
- Low voltage and low power consumption.
- High immunity against ambient light.
- Photodiode with integrated circuit.
- TTL and CMOS compatibility.
- Long reception distance.
- High sensitivity.
- Suitable min. burst length ≥ 6 or 10 pulses/burst.
- Pb free.
- The product itself will remain within RoHS compliant version.

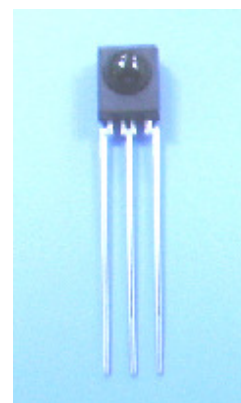

Descriptions

The device is a miniature type infrared remote control system receiver which has been developed and designed by utilizing the most updated IC technology. The PIN diode and preamplifier are assembled on lead frame, the epoxy package is designed as an IR filter. The demodulated output signal can directly be decoded by a microprocessor.

Applications

- Light detecting portion of remote control
- AV instruments such as Audio, TV, VCR, CD, MD, etc.
- Home appliances such as Air-conditioner, Fan , etc.
- The other equipments with wireless remote control.
- CATV set top boxes
- Multi-media Equipment

| PART | MATERIAL | COLOR |
|----------|----------|-------|
| Chip | Silicon | --- |
| Compound | Epoxy | Black |

IRM-36xx SERIES

Package Dimensions

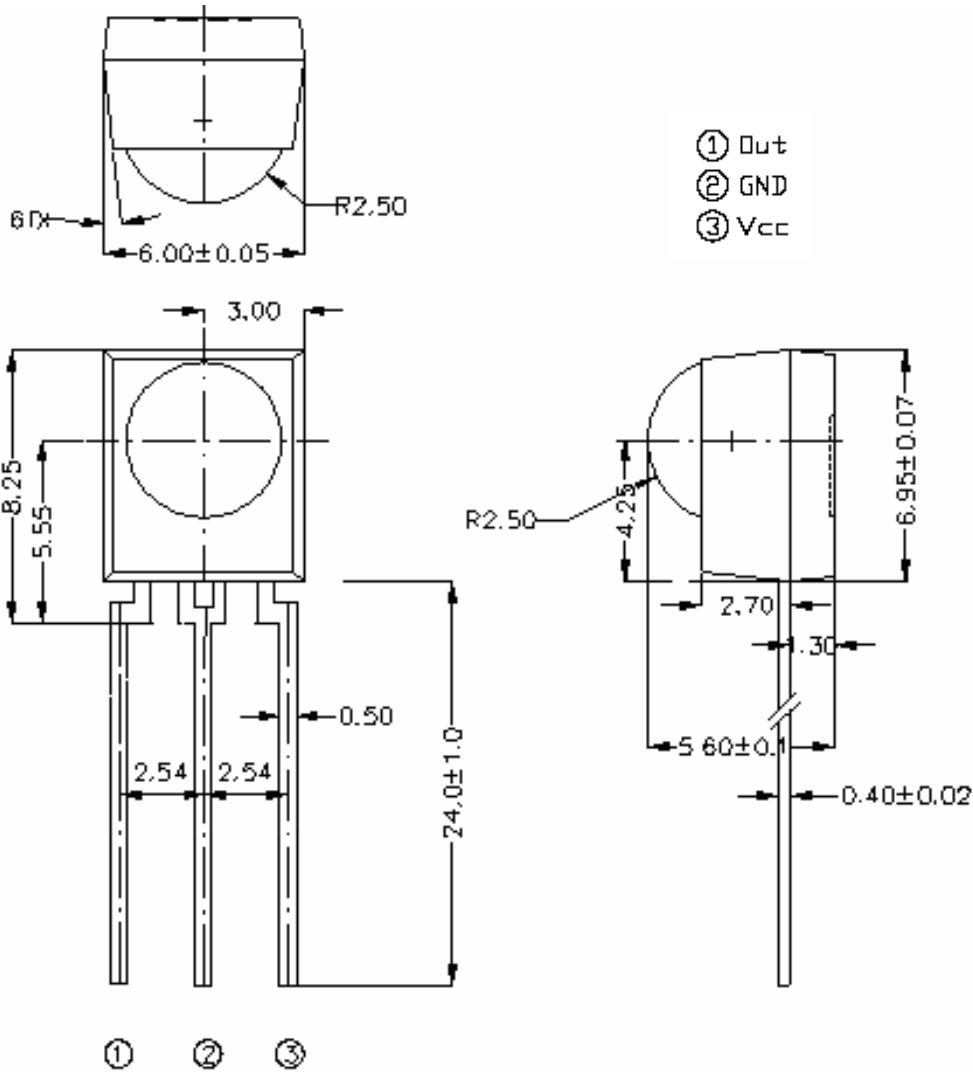

Unit:mm

- Notes:** 1.All dimensions are in millimeters.
2.Tolerances unless dimensions ± 0.3 mm.

Available Types For Different Carrier Frequencies

| Type | Carrier Frequencies (Typ) |
|----------|---------------------------|
| IRM-3636 | 36 kHz |
| IRM-3638 | 38 kHz |

IRM-36xx SERIES
Absolute Maximum Ratings (Ta=25°C)

| Parameter | Symbol | Rating | Unit | Notice |
|-----------------------|--------|-----------|------|---------------------------------|
| Supply Voltage | Vcc | 0 ~ 6 | V | |
| Operating Temperature | Topr | -25 ~ +85 | °C | |
| Storage Temperature | Tstg | -40 ~ +85 | °C | |
| Soldering Temperature | Tsol | 260 | °C | 4mm from mold body less than 10 |

Recommended Operating Condition
Supply Voltage Rating: Vcc 2.7V to 5.5V
Electro-Optical Characteristics (Ta=25°C, and Vcc=3.0V)

| Parameter | Symbol | MIN. | TYP. | MAX. | Unit | Condition |
|---------------------------|-----------------|------|------|------|---------|-----------------------|
| Consumption Current | Icc | --- | --- | 2 | mA | No signal input |
| Peak Wavelength | λ_p | --- | 940 | --- | nm | |
| Reception Distance | L ₀ | 14 | --- | --- | m | At the ray axis *1 |
| | L ₄₅ | 6 | --- | --- | | |
| Half Angle(Horizontal) | Θ_h | --- | 45 | --- | deg | |
| Half Angle(Vertical) | Θ_v | --- | 45 | --- | deg | |
| High Level Pulse Width | T _H | 400 | --- | 800 | μs | |
| Low Level Pulse Width | T _L | 400 | --- | 800 | μs | |
| High Level Output Voltage | V _H | 2.7 | --- | --- | V | |
| Low Level Output Voltage | V _L | --- | 0.2 | 0.5 | V | |

Notes:

*1:The ray receiving surface at a vertex and relation to the ray axis in the range of $\theta=0^\circ$ and $\theta=45^\circ$.

*2:A range from 30cm to the arrival distance. Average value of 50 pulses.

Test Method :

The specified electro-optical characteristics is satisfied under the following Conditions at the controllable distance.

①Measurement place

A place that is nothing of extreme light reflected in the room.

②External light

Project the light of ordinary white fluorescent lamps which are not high Frequency lamps and must be less then 10 Lux at the module surface.
($E_e \leq 10\text{Lux}$)

③Standard transmitter

A transmitter whose output is so adjusted as to $V_o=400\text{mVp-p}$ and the output Wave form shown in Fig.-1.According to the measurement method shown in Fig.-2 the standard transmitter is specified.

However , the infrared photodiode to be used for the transmitter should be $\lambda_p=940\text{nm}, \Delta\lambda=50\text{nm}$. Also, photodiode is used of PD438B($V_r=5\text{V}$).
(Standard light / Light source temperature 2856°K).

④Measuring system

According to the measuring system shown in Fig.-3

Block Diagram :

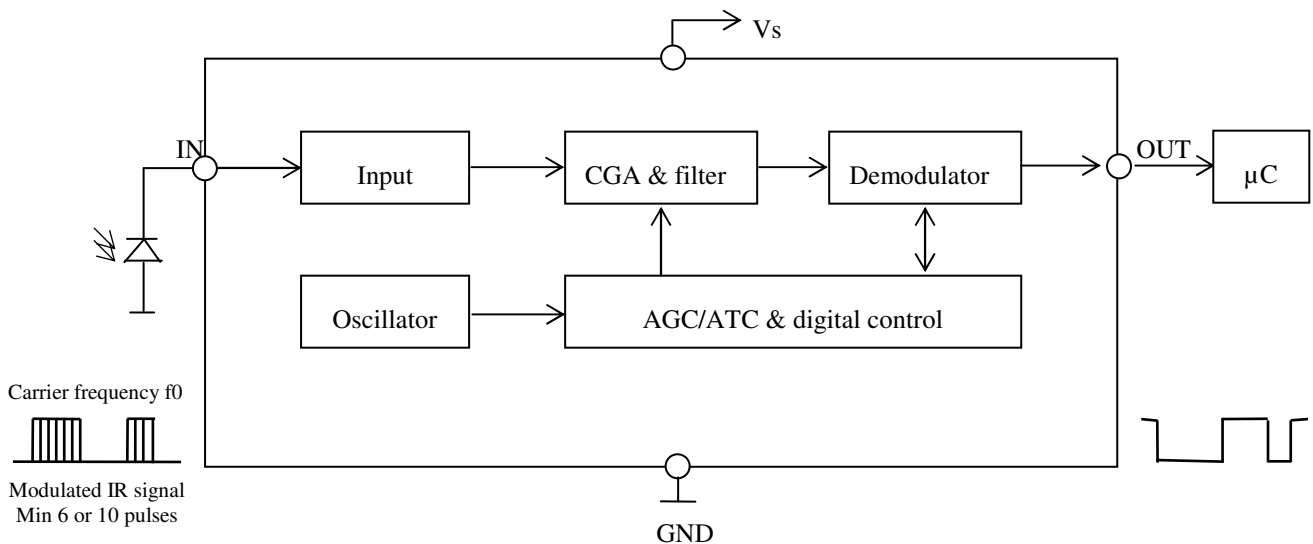

Application Circuit :

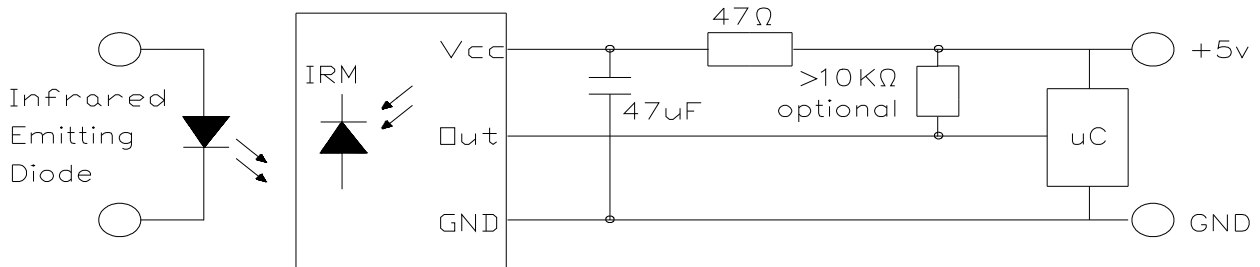

RC Filter should be connected closely between Vcc pin and GND pin.

Fig.-1 Transmitter Wave Form

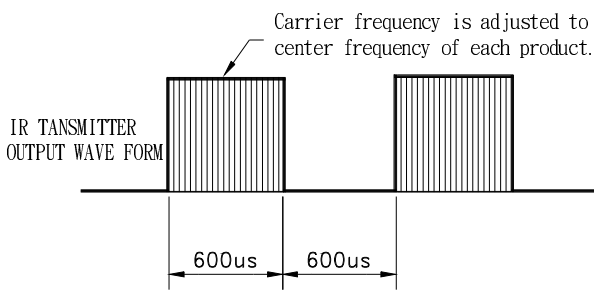

D.U.T output Pulse

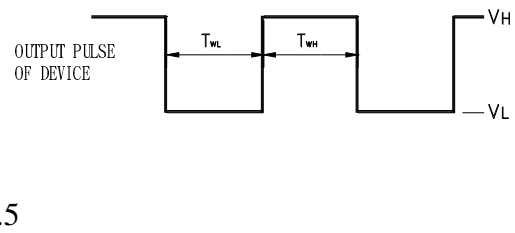

Fig.-2 Measuring Method

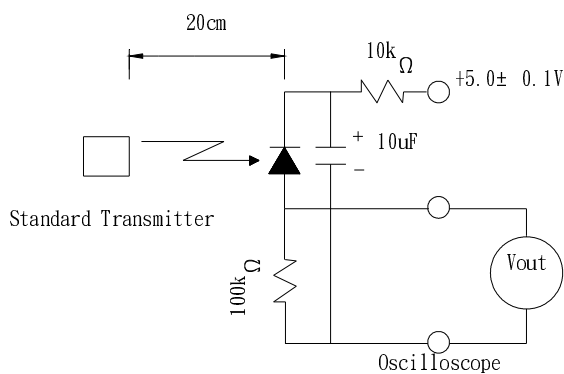
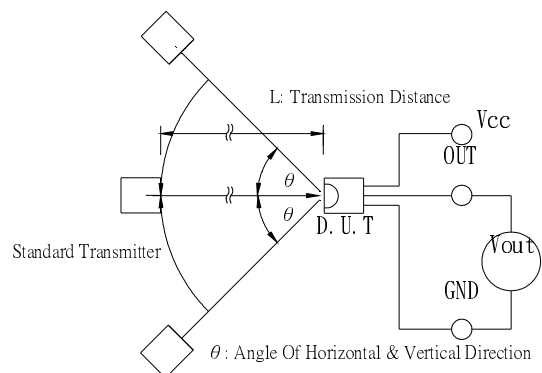

Fig.-3 Measuring System



IRM-36xx SERIES

The Notice of Application: (IRM-36xx SERIES)

Transmission remote control signal consist of four parts: Encode Part, IR Transmitter Source, IRM device, Decode Part

1. When IRM-36xx SERIES code select frequency, it need to well understand the center system of encode part.
2. Strong or weak light of IR Transmitter can affect distance of transmission.
3. Minimum Burst Length T_{burst} (number of pulses per burst) : 6 or 10 cycles
4. It needs to ensure the translation range of decode part if it is applied to the pulse-width range.
5. IRM-36xx SERIES can be applied to the high data codes, but against disturbance slightly weak.

If the above items hardly assure of its application, it'll cause NG(no good) message from the edge of signal.

Typical Electro-Optical Characteristics Curves

Fig.-4 Relative Spectral Sensitivity vs. Wavelength

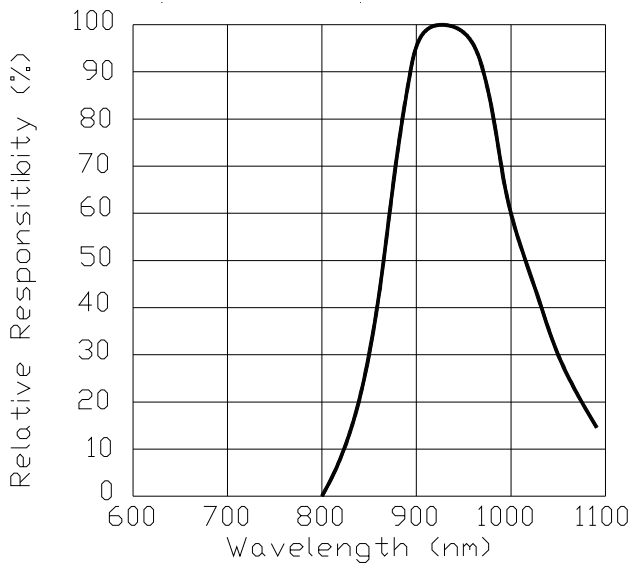
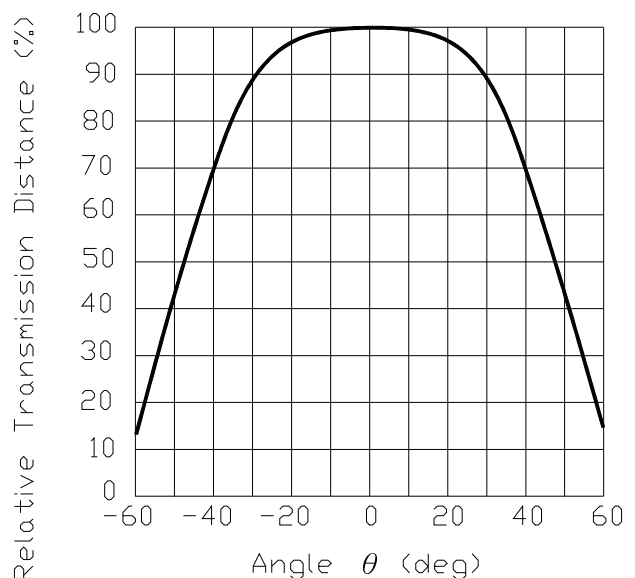

Fig.-5 Relative Transmission Distance vs. Direction



Typical Electro-Optical Characteristics Curves

Fig.-6 Output Pulse Length vs. Arrival Distance Fig.-7 Arrival Distance vs. Supply Voltage

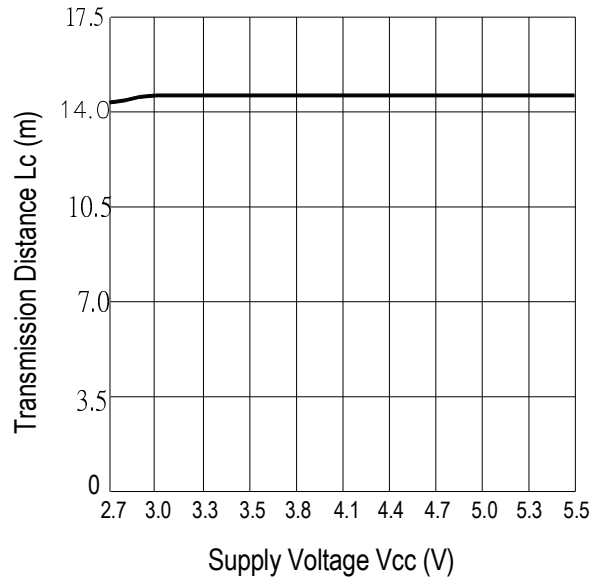
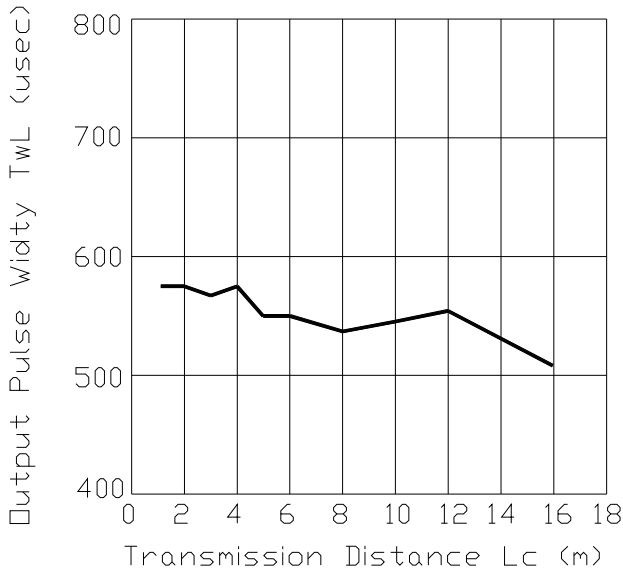
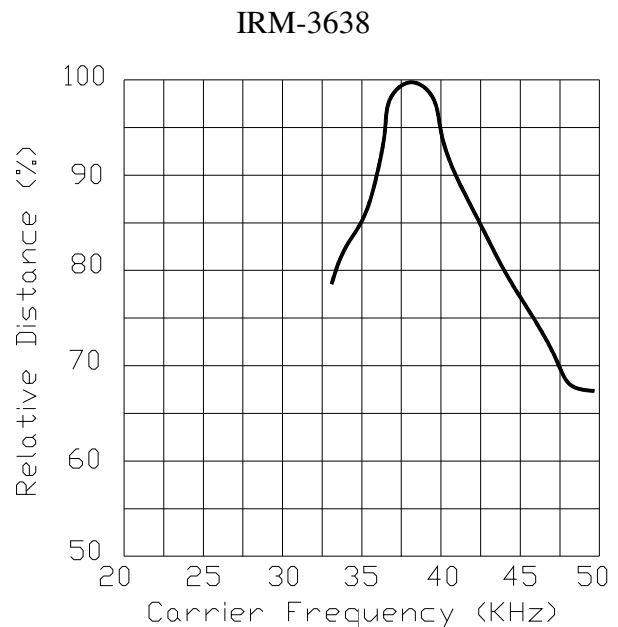
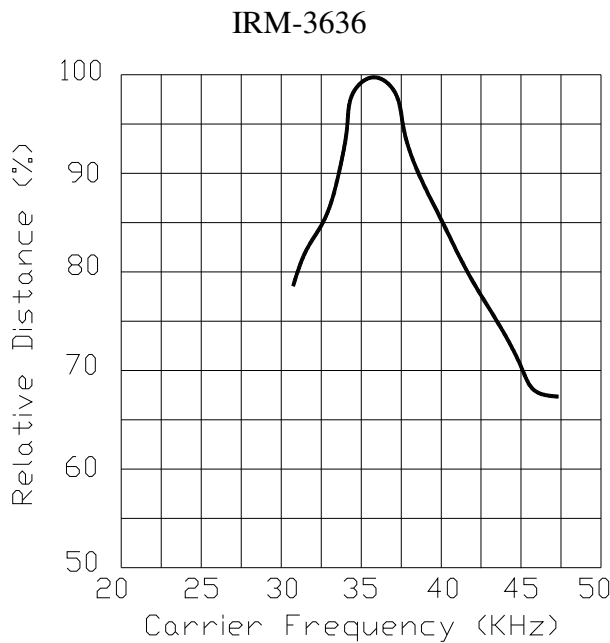
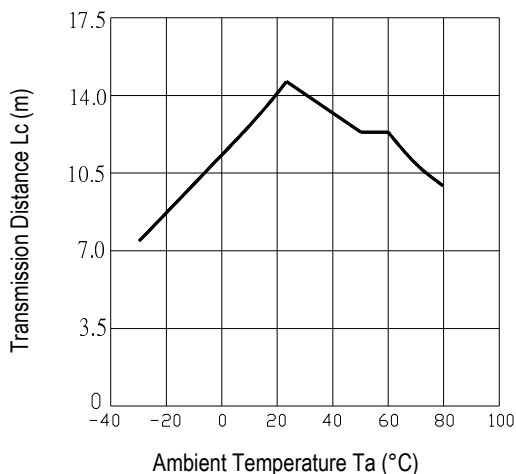

Fig.-8 Relative Transmission Distance vs. Center Carrier Frequency



Typical Electro-Optical Characteristics Curves

Fig.-9 Arrival Distance vs. Ambient Temperature



Reliability Test Item And Condition

The reliability of products shall be satisfied with items listed below.

Confidence level : 90%

LTPD : 10%

| Test Items | Test Conditions | Failure Judgement Criteria | Samples(n) Defective(c) |
|--------------------------------|--|---|----------------------------|
| Temperature cycle | 1 cycle -40°C ↔ +100°C (15min)(5min)(15min) 300 cycle test | L ₀ ≤ L×0.8 L ₄₅ ≤ L×0.8 L: Lower specification limit | n=22,c=0 |
| High temperature test | Temp: +100°C Vcc:6V 1000hrs | | n=22,c=0 |
| Low temperature storage | Temp: -40°C 1000hrs | | n=22,c=0 |
| High temperature High humidity | Ta: 85°C ,RH:85% 1000hrs | | n=22,c=0 |
| Solder heat | Temp: 260±5°C 10sec 4mm From the bottom of the package. | | n=22,c=0 |

Packing Quantity Specification

1. 1500PCS/1Box
2. 10Boxes/1Carton

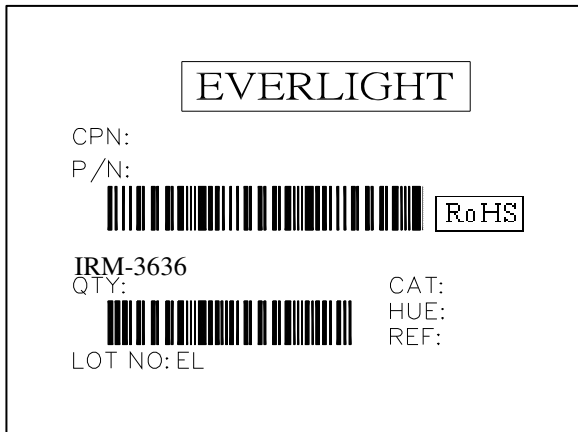
Label Form Specification

CPN: Customer's Production Number

P/N : Production Number

QTY: Packing Quantity

CAT: Ranks

HUE: Peak Wavelength

REF: Reference

LOT No: Lot Number

MADE IN TAIWAN: Production Place

Notes

1. Above specification may be changed without notice. EVERLIGHT will reserve authority on material change for above specification.
2. When using this product, please observe the absolute maximum ratings and the instructions for using outlined in these specification sheets. EVERLIGHT assumes no responsibility for any damage resulting from use of the product which does not comply with the absolute maximum ratings and the instructions included in these specification sheets.
3. These specification sheets include materials protected under copyright of EVERLIGHT corporation. Please don't reproduce or cause anyone to reproduce them without EVERLIGHT's consent.

EVERLIGHT ELECTRONICS CO., LTD.Office: No 25, Lane 76, Sec 3, Chung Yang Rd,
Tucheng, Taipei 236, Taiwan, R.O.C

Tel: 886-2-2267-2000, 2267-9936

Fax: 886-2267-6244, 2267-6189, 2267-6306

<http://www.everlight.com>