



Product division: NTC

Product type: S234/60/M\*

Product name: Inrush Current Limiter

Ordering code: B57234S0600Mxxx

Data sheet

## APPLICATION :

NTC-thermistor for inrush current limiting in peripheral communication equipment, e.g. in switch-mode power supplies

## FEATURES :

- Black coated thermistor disk
- Coating material is flame retardant (UL 94 V-0 approved)
- Kinked leads of tinned copper wire
- Lead spacing 7.5 mm
- Manufacturer's logo, NTC and resistance value stamped in white
- High stability of electrical characteristic
- Terminals solderable in accordance with IEC 60068-2-20, test ta, method 1
- ICL support to fulfill the requirements according EN 61000 of power circuits
- Usable in series connections up to 265 V<sub>rms</sub>
- The component is compliant with ROHS (DIRECTIVE 2002/95/EC OF THE EUROPEAN PARLIAMENT AND THE COUNCIL of 27 January 2003 on the restriction of the use of certain hazardous substances in electrical and electronic equipment
- Also available on tape

© EPCOS AG 2005. Reproduction, publication and dissemination of this data sheet, enclosures hereto and the information contained therein without EPCOS' prior express consent is prohibited.

Purchase orders are subject to the General Conditions for the Supply of Products and Services of the Electrical and Electronics Industry recommended by the ZVEI (German Electrical and Electronic Manufacturers' Association), unless otherwise agreed.

ISSUE DATE	11.05.05	ISSUE	a	PUBLISHER	KB S PE	PAGE	1/10
------------	----------	-------	---	-----------	---------	------	------

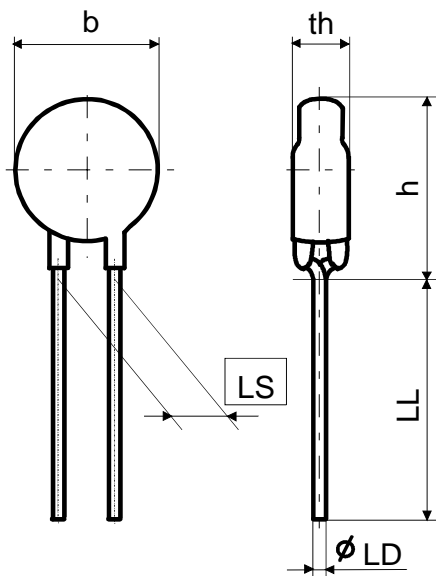
**DRAWING :**

b	15.0max	mm
th	7.0 max	mm
h	22.0 max	mm
LL	32 <sup>+3</sup>	mm
LD	0.8 <sup>±0.05</sup>	mm
LS	7.5 <sup>±0.8</sup>	mm

Approx. weight : 2.0 [g]

**RATINGS AND CHARACTERISTICS**

Lower/upper category temperature	T	[°C]	<b>-55/+170</b>
Resistance tolerance	$\Delta R/R_N$	[%]	<b>± 20</b>
Rated temperature	T <sub>N</sub>	[°C]	<b>25</b>
B value tolerance	$\Delta B/B$	[%]	<b>± 3</b>
Max. power at 25°C	P <sub>max</sub>	[W]	<b>3.6</b>
Dissipation factor (in air)	$\delta_{th}$	[mW/K]	<b>approx. 17</b>
Thermal cooling time constant (in air)	$\tau_{th}$	[s]	<b>approx. 90</b>
Heat capacity	C <sub>th</sub>	[mJ/K]	<b>approx. 1530</b>

Ordering Code	R <sub>25</sub> [Ω]	I <sub>max</sub> [A]	B <sub>25/100</sub> [K]	C <sub>T</sub> at 110 VAC [μF]	C <sub>T</sub> at 230 VAC [μF]	Parameter for R(I) k	Parameter for R(I) n
B57234S0600Mxxx	60	4.0	4000	1600	400	1.77	-1.44

**Data sheet**
**Maximum continuous current  $I_{max}$  :**

The  $I_{max}$  denotes the maximum permissible continuous current (dc or rms values for sine-shaped ac) in the temperature range 0 to 65°C.

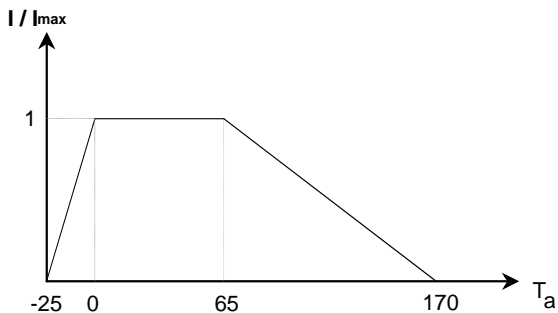
**Maximum current derating ( $I / I_{max}$ ) :**

$$\text{Percent of } I_{max} = 100 \left[ 1 - \frac{T_A - 65^\circ C}{T_{max} - 65^\circ C} \right]$$

$T_A$  = ambient temperature ( $T_A > 65^\circ C$ )  
 $T_{max} = 170^\circ C$

Fig. 1. - Maximum current derating ( $I / I_{max}$ )

**Maximum switchable capacity ( $C_T$ ) :**

The maximum switchable capacity ( $C_T$ ) is the maximum capacity which may be discharged across the thermistor. See Fig.2 Maximum switchable capacity measuring circuit.

**Dependence of NTC resistance on current :**

The resistance effective in the usual current range can be approximated with the fit parameter **k** and **n**.

$$R_{NTC} = k * I^n \quad 0.3 * I_{max} < I \leq I_{max}$$

$R_{NTC}$  Resistance value to be determined at current  $I$  [ $\Omega$ ]

$k, n$  Fit parameter, see table with ordering codes

$I$  Current flowing through the NTC (insert numerical value in A)

The calculated values only serve as an estimate for operation in still air at an ambient temperature of 25°C.

**MARKING :**

- EPCOS – logo
- resistance value
- NTC
- Date code with 4 digits (year and week of production): 0540 (example for week 40 in year 2005)

ISSUE DATE	11.05.05	ISSUE	a	PUBLISHER	KB S PE	PAGE	3/10
------------	----------	-------	---	-----------	---------	------	------



Product division: NTC

Product type: S234/60/M\*

Product name: Inrush Current Limiter

Ordering code: B57234S0600Mxxx

Data sheet

### Resistance - Temperature Curve

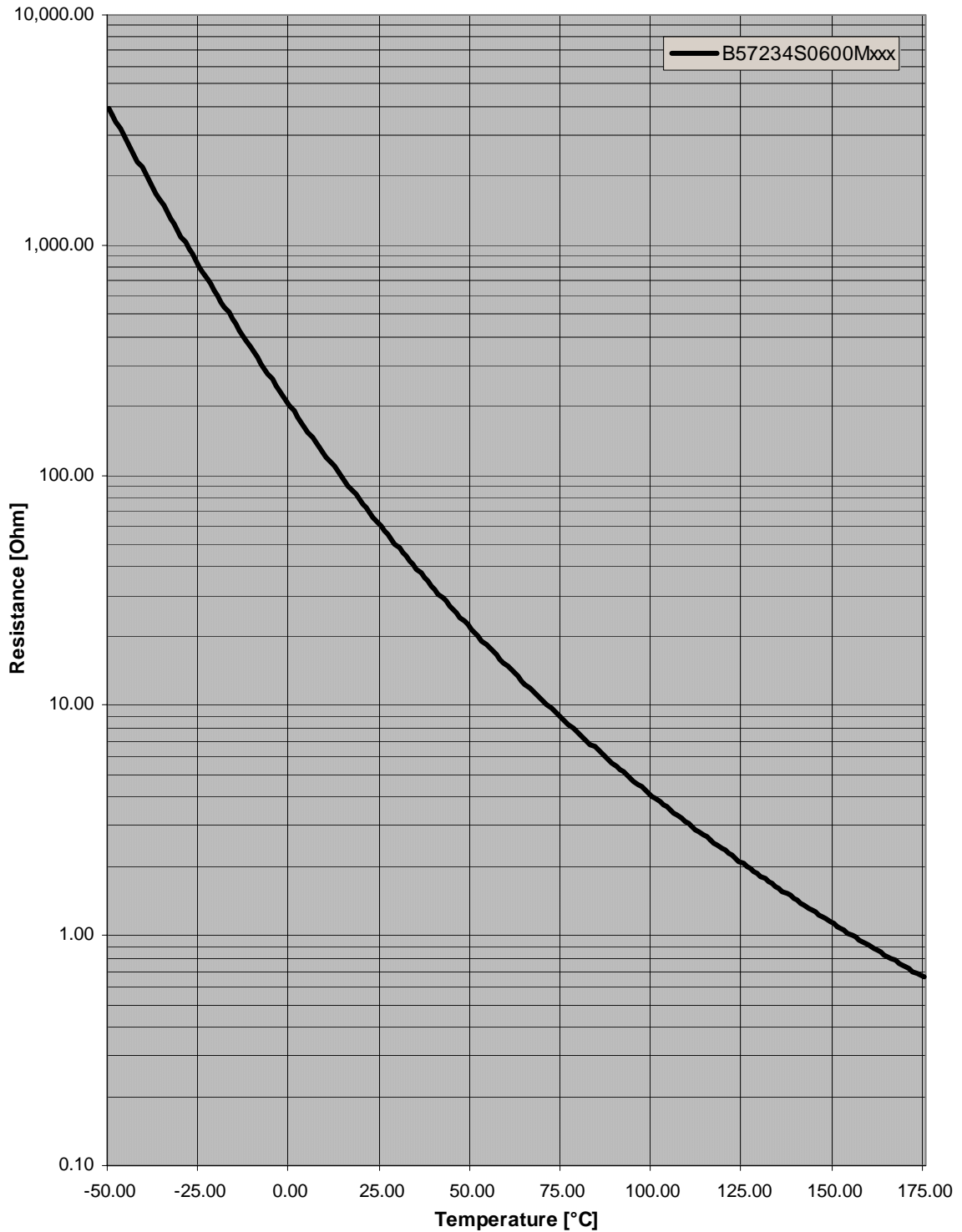

ISSUE DATE	11.05.05	ISSUE	a	PUBLISHER	KB S PE	PAGE	4/10
------------	----------	-------	---	-----------	---------	------	------



Product division: NTC

Product type: S234/60/M\*

Product name: Inrush Current Limiter

Ordering code: B57234S0600Mxxx

Data sheet

## ROBUSTNESS OF TERMINATIONS :

The leads meet the requirements of IEC 60068-2-21.

Test	Test conditions	Remarks
Tensile strength	Test Ua1: Fasten body with a force applied to each lead 10 [N] for 10 [s]	No visible damage
Bending strength	Test Ub: Fasten body with two 90°-bends in opposite direction at a force of 10 [N]	No visible damage (Peel off of coating along the lead accepted)

## RELIABILITY REQUIREMENTS :

Test	Standard	Test conditions	$\Delta R_{25}/R_{25}$ (typical)	Remarks
Storage in dry heat	IEC 60068-2-2	Storage at upper category temperature T: 170°C t: 1 000 h	< 10 %	No visible damage
Storage in damp heat, steady state	IEC 60068-2-3	Temperature of air: 40°C Relative humidity of air: 93 % Duration: 21 days	< 5 %	No visible damage
Rapid change of temperature	IEC 60068-2-14	Lower test temperature: -55°C (time: 15 min) Upper test temperature: 170°C (time: 15 min) Time to change from lower to upper temperature : < 30 sec Number of cycles: 10	< 10 %	No visible damage
Endurance (storage at max. current)		$I = I_{max}$ t = 1000 h T = 25°C	< 10 %	No visible damage
Electrical cycling test	*	$I = I_{max}$ load on: 1 min load off: 6 min Number of cycles: 1000	< 10 %	No visible damage
Maximum switchable capacity test	**	Capacity = $C_T$ Number of cycles: 1000	< 5 %	No visible damage

ISSUE DATE	11.05.05	ISSUE	a	PUBLISHER	KB S PE	PAGE	5/10
------------	----------	-------	---	-----------	---------	------	------

## Soldering of Components

Process	Conditions	Remarks
Soldering	<b>Dip soldering</b> : 260°C max, 4 sec max, 6mm min from thermistor body <b>Iron soldering</b> : 360°C max, 2 sec max, 6 mm min from thermistor body	Low resistance drift

\* Electrical cycling Test

Each cycle has to start with parts cooled down to room temperature. It has to cover the portion of the R/T curve between room temperature and the resistance of the components as stabilized at the maximum continuous current  $I_{max}$  (that is the minimum operating resistance). One cycle lasts 7 minutes.

\*\* Maximum switchable capacity test

The capacitor ( $C_T$ ) is discharged across a series fixed resistor and the thermistor, shown in Figure 2. The charge voltage is chosen so that the voltage applied to the thermistor at the beginning of discharge is 170/345 [V], corresponding to  $(110/230V + \Delta V) * 1.41$ .

The capacitor is discharged across a series fixed resistor and the thermistor 1 000 times at ambient temperature of between 15°C and 35°C. Each cycle has to start with thermistors cooled down to ambient temperature.

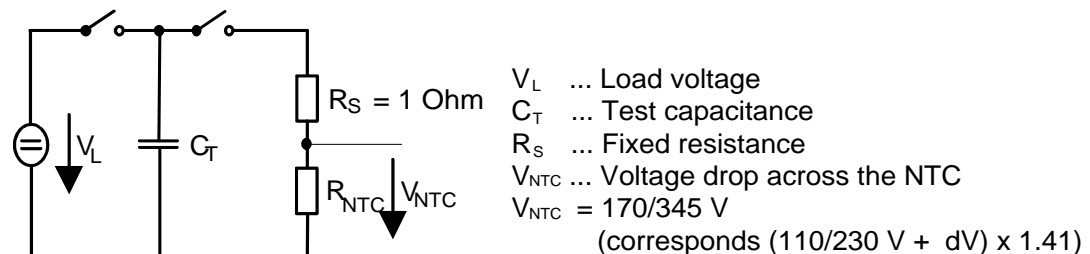

Fig. 2. - Maximum switchable capacity measuring circuit

## TAPING AND PACKING :

### Packing codes :

The last two digits of the complete ordering code state the packing mode :

Packing		Code	Number of Pieces
Bulk packing	Bulk	00	500
Reel packing	Tape	51	1000
AMMO packing	Tape	54	750

**Data sheet**

Example :    B57234S0600M000    untaped  
                  B57234S0600M051    taped reel packing

**Table 1: Package dimensions and weights of unit packages**

Packing	Pcs / unit	Approx. Weight (g)	Dimensions (mm)
Bulk	500	1100	x=65, y=230, z=125
Ammo	750	2100	x=56, y=355, z=355
Reel	1000	2500	d=500, f=23±1, n=approx. 59, w=72 max

Dimensions x, y, z acc. to fig. 1

Dimensions d, f, n, w acc. to fig. 2

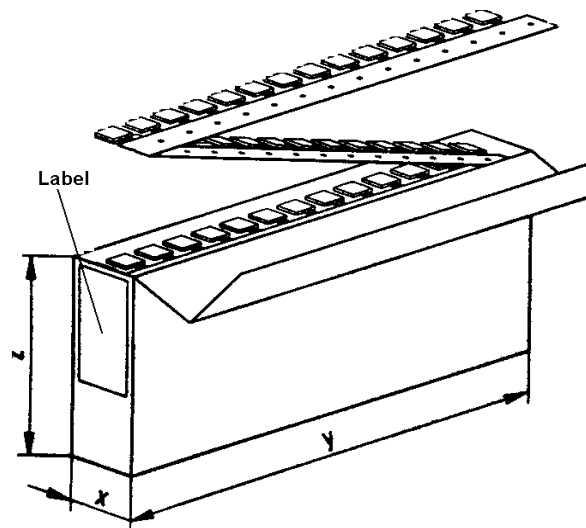
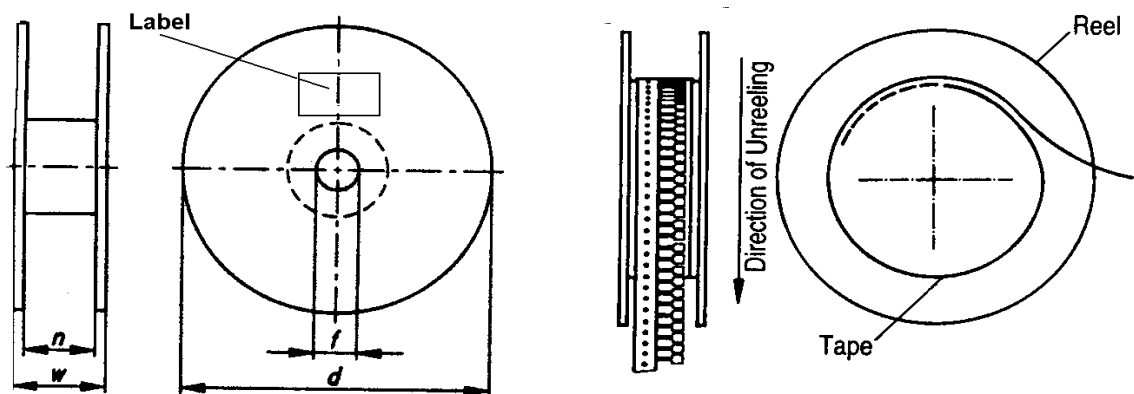
**Drawings**

**Fig. 1: AMMO packing**

**Fig. 2: Reel packing**

ISSUE DATE	11.05.05	ISSUE	a	PUBLISHER	KB S PE	PAGE	7/10
------------	----------	-------	---	-----------	---------	------	------

**Data sheet**
**Shipping package**
**Table 2: Dimensions and weights of shipping package.**

BULK		
Dimensions L x W x H (mm)	Pcs/package -	Approx. Weight (kg)
330x230x100	1000	3.1
260x180x190	1500	4.3
360x360x130	4000	11.5
370x270x270	6000	16.8
354x354x274	7500	21.2

AMMO		
Dimensions L x W x H (mm)	Pcs/package -	Approx. Weight (kg)
354x354x58	750	2.6
354x354x112	1500	4.8
354x354x166	2250	7.0
354x354x220	3000	9.2
354x354x274	3750	11.4

REEL		
Dimensions L x W x H (mm)	Pcs/package -	Approx. Weight (kg)
505x505x74	1000	3.5
505x505x220	3000	9.8
505x505x360	5000	15.7

L x W x H acc. to fig. 3.

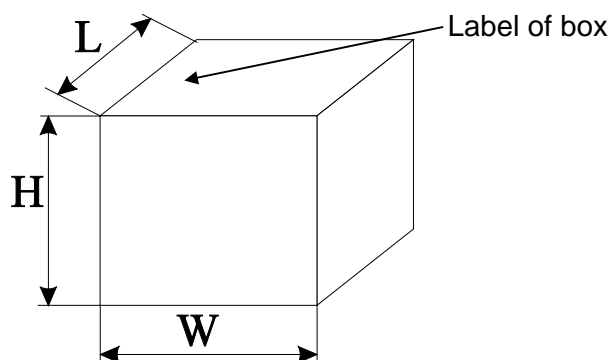
**Drawing**

**Fig. 3: Shipping Package**

**Packing material: Cardboard box**

ISSUE DATE	11.05.05	ISSUE	a	PUBLISHER	KB S PE	PAGE	8/10
------------	----------	-------	---	-----------	---------	------	------



Data sheet

**Label**

The shown label is an example for bulk packing. Type code and ordering code do not refer to the actual type.

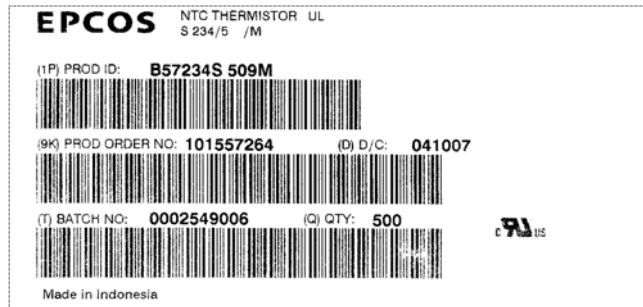

**Internal Construction**

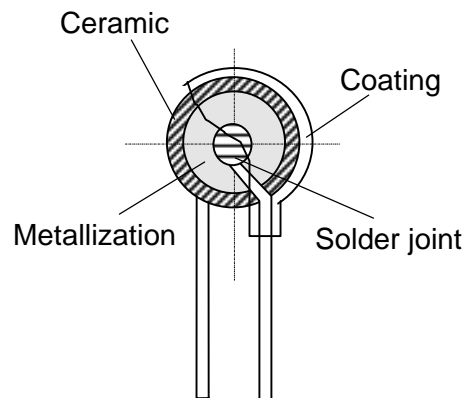

The above picture shows the internal construction of EPCOS ICL's.

Note: Coating may have cracks or chips due to acting mechanical force on the wire, but this does not affect the performance of the component

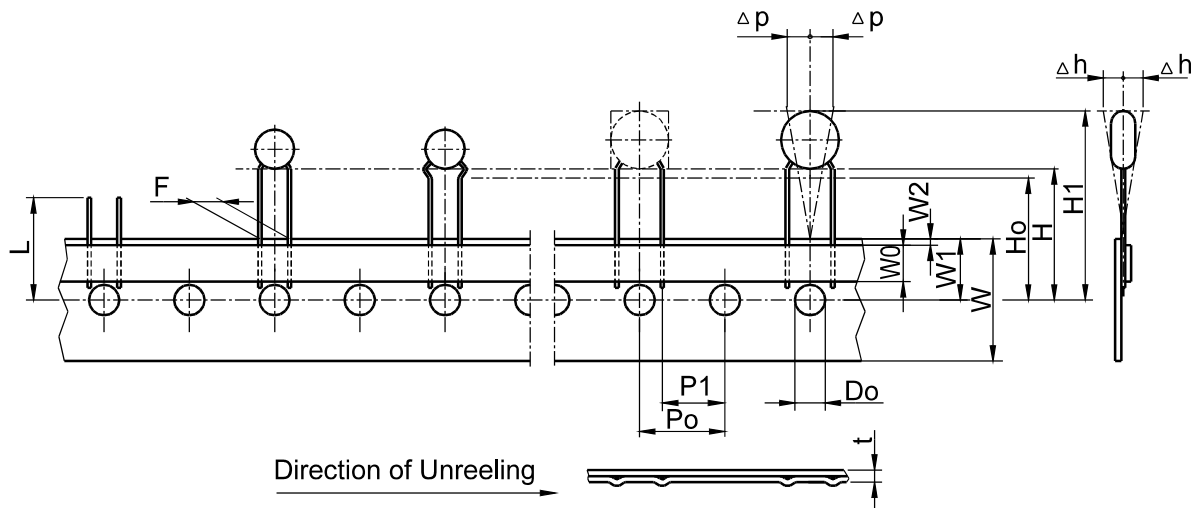
**Data sheet**
**Taping specification :**

Dimensions and tolerances (taping in accordance with IEC 60286-2) :

Designation	Symbol	Nominal size [mm]	Tolerance [mm]	Remarks
Lead Spacing	F	7.5	± 0.8	
Pitch of holes	P0	12.7	± 0.3	± 1 mm/20 sprocket holes
Spacing hole center	P1	8.95	± 0.8	
Slope of component	Δ h	0	± 2.0	measured at top of component body
Slope of component	Δ p	0	± 2.0	
Spacing hole center / bottom edge of component	H	18.0	+2.0/-0	
Spacing hole center / niveau NTC	H0	16.0	± 0.5	
Spacing hole center / upper edge of component	H1	45.0	max.	
carrier type width	W	18.0	± 0.5	
hot adhesive tape width	W0	5.5	min.	peel-off force ≥ 5 N
position of holes	W1	9.0	+0.75/-0.5	
position of adhesive tape	W2	3.0	max.	
hole diameter	D0	4.0	± 0.2	
tape thickness	t	0.9	max.	without wires
length of remaining wire after removal of component	L	11.0	max.	