



# W1G250 Series

Tubeaxial

280x280x80mm

- DC fans with electronically commutated external rotor motor. Fully integrated commutation electronics.
- Maintenance-free ball bearings.
- Die-cast aluminum housing. Impeller of sheet steel, welded onto rotor and stove-enameled.
- Mounting from either face using four 4.3 mm holes.
- Air exhaust over struts. Rotational direction CCW looking at rotor.
- Connecting leads with terminal strip.
- UL, CSA, VDE approvals on some models, please contact application engineering.

| Part Number    | CFM @ 0 | VDC | Volt. Range | Power (W) | dBA | Max Amb. Temp C | Bearing Type | Features       | Wgt. (lbs) |
|----------------|---------|-----|-------------|-----------|-----|-----------------|--------------|----------------|------------|
| W1G250-HH35-52 | 1089    | 24  | 16 to 28    | 95.0      | 68  | 60              | Ball         | Terminal Block | 4.63       |
| W1G250-HH73-52 | 1089    | 48  | 36 to 56    | 95.0      | 68  | 60              | Ball         | Terminal Block | 4.63       |

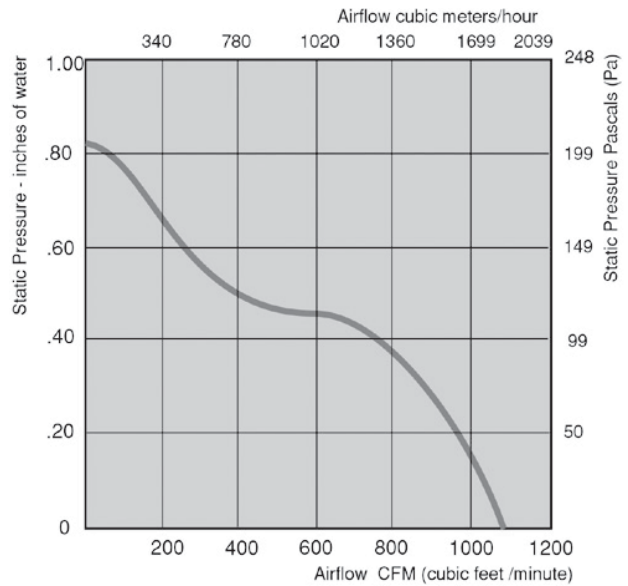
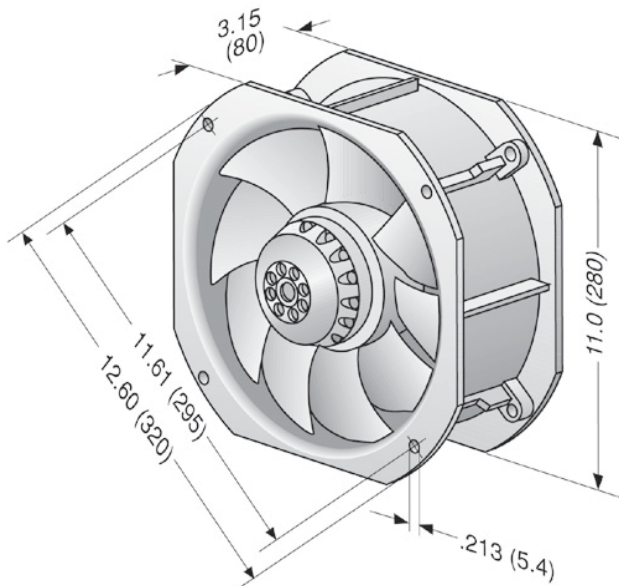

**ebmpapst**

e-mail: [sales@us.ebmpapst.com](mailto:sales@us.ebmpapst.com) · TEL: 860-674-1515 · FAX: 860-674-8536

ebm-papst Inc., 100 Hyde Road, Farmington, CT 06034 USA

ebm-papst Inc., 2004 © ebm-papst Inc. reserves the right to change any specifications or data without notice