

8314/19H DC Axial Fan

80mm axial fan with high air flow. The DC drive employs an electronically commutated external rotor motor with high efficiency. Drive electronics is completely integrated into the fan hub. The air flow and noise level can be controlled by varying the supply voltage range.



Features

- Electronic protection against locking or overload.
- Electronic reverse polarity protection. Fan starts only with correct polarity.
- Alarm output signal type /19; high on fail; for details please refer to alarm specification attached.
- Electrical connection via 3 leads AWG 22, TR64, 310mm long, stripped and tinned ends (red = +24V; black = GND; yellow = alarm)

Patents granted or applied for.

General Data

Nominal voltage	V DC	24
Voltage range	V DC	12 ... 26.5
Nominal speed	rpm	5000 (+/- 7,5 %)
Max. flow rate	m ³ /h	80
Max. flow rate	CFM	47
Noise free air	dB(A)	48
Noise in optimum operating range	bels	6.2
Current consumption	mA	270
Power consumption	W	6.4
Permanent ambient temperature at max. voltage	°C	-20 ... +65
Service life (65 °C)	h	37.500
Service life (40 °C)	h	70.000
Approvals	UL, VDE, CSA	
Fan housing / impeller	PBTP / PA 6.6	
Bearing system	Ball bearings	
Mass	kg	0,170

All data are mean values at nominal conditions.

Subject to change without notice

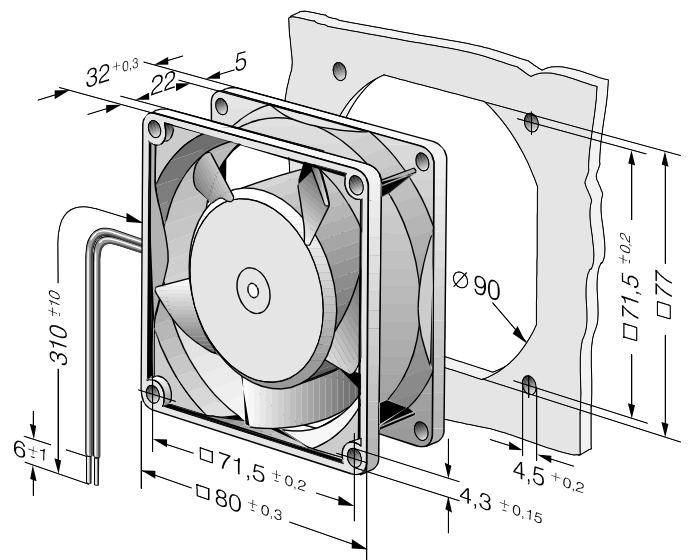
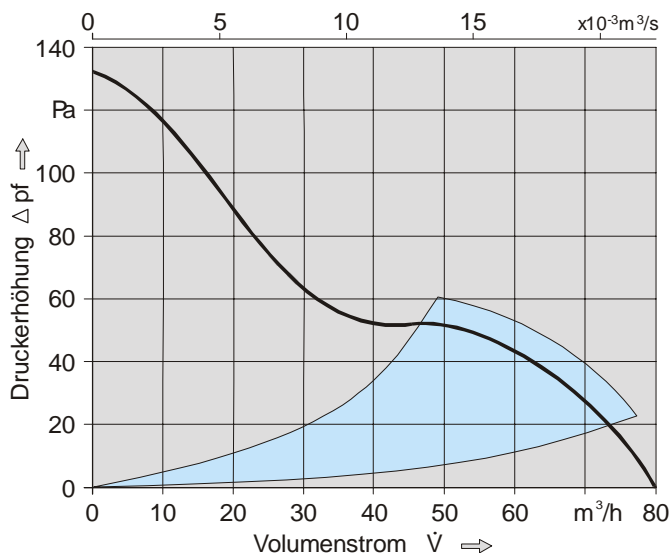

Alarm Signal Output:

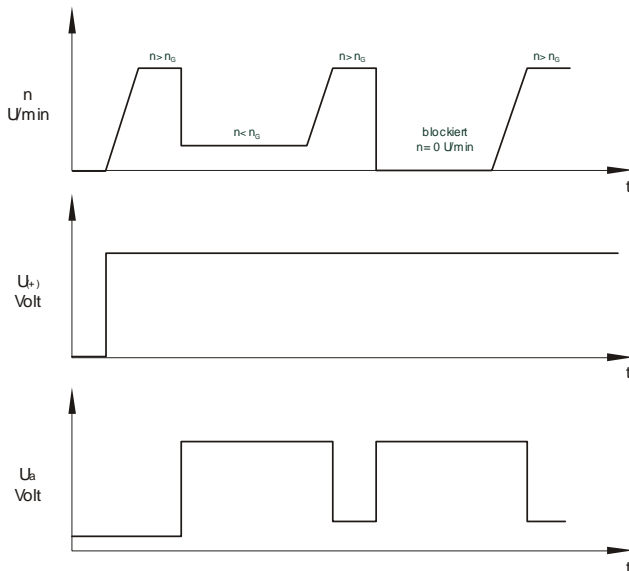
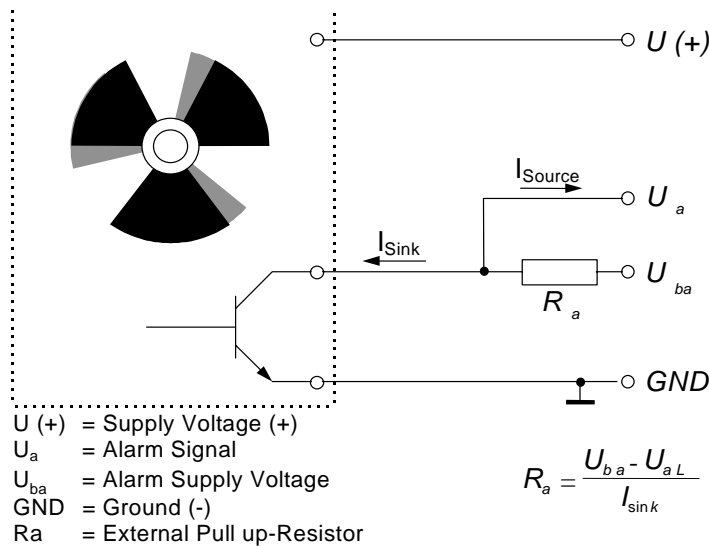

Technical Data

Alarm Circuit

This fan is equipped with an integrated alarm circuit producing a continuous output signal U_a for monitoring fan speed. At proper operation in the nominal voltage range the alarm output is a „low“ level. When speed decreases below limit speed $n_G = 1500\text{rpm}$ (+/-100rpm), e.g. by high friction torque, locked rotor condition, or low operating voltage, a „high“ level output will occur. When speed recovers, the alarm signal goes back to „low“, i.e. alarm is non-latched.

Designation	Test condition	Symbol	Value
Alarm output voltage		$U_{ba} \text{ max}$	60 V DC
Max. sink current		$I_{sink} \text{ max}$	20 mA
Output voltage "Low" $n < n_G$	$I_{sink} = 20 \text{ mA}$	$U_a \text{ L}$	$\leq 0,3 \text{ V}$
Output voltage "High" $n > n_G$		$U_a \text{ H}$	$\leq 60 \text{ V}$
Leakage current $n > n_G$	$U_a = 60 \text{ V}$	I_{sink}	max. $15\mu\text{A}$
Alarm delay time	at start up only	t_2	$< 15 \text{ s} \pm 1 \text{ s}$
Signal rise and fall time U_a		t_r, t_f	min. $0,5\text{V}/\mu\text{s}$ (Stand TTL)
Alarm trip speed		n_G	1500rpm $\pm 100\text{rpm}$

$t_r \rightarrow$ Low-High

$t_f \rightarrow$ High-Low

Alarm Signal suppressed at start-up