

Description

The term firefighter switch indicates a device where the DC side of a photovoltaic system in proximity of the modules (or directly below the cable outlet) can be de-energised. It is intended to reduce or eliminate all difficulties or risks connected with fire fighting, high water or technical aid. De-energisation of the strings will occur immediately after shutdown of the supply voltage. An automatic restart ensures smooth and undisturbed operation of the photovoltaic system even in the event of voltage interruption unless there is a manual switching operation. The restart also allows reliable and safe operation of more than one, even hardly accessible firefighter switches.

US patent number: US 8,742,828 B2

US patent number: US 8,766,760 B2 (Fail-Safe-Element)

Features

- Double pole DC Disconnect (firefighter switch version) for disconnecting a PV string
- Disconnection e.g. after actuation of an emergency switch or firefighter safety switch (not part of the product) as well as by voltage interruption
- Automatic restart after voltage interruptions unless there is an intentional switching operation
- Lock-out feature in OFF condition
- Integral fail-safe function
- standard with auxiliary contact
- Meets the requirements of VDE-AR-E 2100-712

Typical applications

The firefighter switch has been designed for use in photovoltaic system and allows supporting measures during firefighting or technical aid by reliable disconnection of DC strings in the house. Customer-friendly rail mounting and compact size require only very little space and allow installation in a distribution box.

Relevant standards

Standard	Rated voltage	Current rating range
IEC/EN 60947-3	DC 1,000 V	Up to 35 A

Ordering information

Type
PVSEC firefighter safety switch PVSEC-...
Mounting method
T1 track-mountable (black enclosure, blue toggle)
Version
01 2-pole, screw terminals, lock-out feature
Voltage rating
DC 1000 V
Current rating
35 A
PVSEC-T1 01 - DC 1000 V-35 A

All dimensions without tolerances are for reference only. In the interest of improved design, performance and cost effectiveness the right to make changes in these specifications without notice is reserved. Product markings may not be exactly as the ordering codes. Errors and omissions excepted.



Technical data

Technical data DC Disconnection for type PVSEC-...

Rated operational voltage (U_e)	DC 1,000 V
Rated current (I_e)	up to 35 A (higher ratings upon request)
Number of poles	2-pole
Internal resistance	typically 6 m Ω
Total power loss	9 W (at 35 A)
Method of operation	S – type
Operation mode	permanent
Rated insulation voltage (U_i)	DC 1500 V
Rated impulse withstand voltage (U_{imp})	8 kV
Pollution degree	2
Overvoltage category	III

General data

Fail-safe-element	integral
Screw terminal thread	M 4
tightening torque	1.2 Nm
Max. cable cross sections	
rigid (single or multi-wired)	0.5 – 16 mm ²
flexible with wire end ferrule or with plastic sleeve	0.5 – 10 mm ²
flexible with TWIN-wire end ferrule	0.5 – 6 mm ²
cable cross section AWG	20 – 6
multi-conductor cables excluded	

Technical data for remote control and zero voltage release module for type PVSEC-...

Rated operational voltage	DC 24 V
Rated insulation voltage	DC 32 V
Voltage range	DC 20...26,4 V
Closed current	typically 70 mA
Auxiliary circuit	DC 24 V; 0.3 A
Terminal design	spring-loaded terminals
ON duty	50 % / 60 sec.

Technical data

Dielectric strength (IEC 60947-1)	
DC 24 V input (+/-) to aux. contact (11,12,14)	test voltage AC 1,000 V / DC 1415 V
open aux. contact	test voltage AC 500 V

General data

Max. cable cross section	
single wired H05(07) V-U	0.25 – 1.5 mm ²
multi-wired H07 V-R	0.25 – 1.5 mm ²
flexible H05(07) V-K	0.25 – 1.5 mm ²
flexible with wire end ferrule	0.25 – 1.5 mm ²
wire end ferrule with moulded collar	0.25 – 0.75 mm ²
stripping length	8.0 +1.0 mm

Technical data for complete system type PVSEC-...

Utilisation category	DC-21 B
Insulation resistance	> 100 MΩ (DC 500 V)
Trip time to ON condition	typically 4 sec.
Trip time to OFF condition	typically < 1 sec.
Protection class	
operation area	IP30
terminal area	IP20
Typical life to IEC 60947-3, test seq. II	
120 cycles per hour	
test current	1 x I _e 35 A
test voltage	1 x U _e DC 1.000 V
time constant	1 ms
cycles	300 electrically / 1,700 mechanically

Rated short-time withstand current (I _{cw})	400 A
---	-------

Rated short-circuit making capacity (I _{cm})	400 A
--	-------

General data

Lock-out feature	padlock Ø 3 – 4.3 mm
Bracket diameter	
Design to	143 x 90 x 84.5 mm
DIN 43880 (l x w x h)	
Mounting method	rail mounting to EN 50022-35x 7.5
Vibration resistance (sinusoidal)	
test to IEC 60068-2-6,	
test Fc, 10 frequency cycles/axis	
± 0.23 mm (10 - 57 Hz) and 3 g (57 - 2,000 Hz)	
Shock	
test to IEC 60068-2-27, test Ea	
10 g (11 ms)	
Corrosion	
test to IEC 60068-2-11, test Ka	
96 hrs. in 5 % salt mist	
Humidity	
test to IEC 60068-2-78, test Cab	
96 hrs. in 95 % RH, temperature 40 °C	
Temperature range	
operation:	-30°C up to +60°C
storage:	-40°C up to +60°C
Mass	approx. 560 g, IEC version (2-pole)

User instructions

- Humidity in the installation area (e.g. caused by condensation) must be avoided.
- The visual status indication of the PVSEC-... must not be blocked.
- It must be ensured in the application that each control unit is supplied with at least 1 A. For suitable switch mode power supplies please see E-T-A product series „SMP ...“
- Safety functions
 - After ten cycles within one minute type PVSEC-... will be blocked for two minutes. If another ten cycles occur immediately after, type PVSEC-... will be blocked entirely and can only be re-activated by the manufacturer.
 - In the event of overvoltage or undervoltage, start-up of the PVSEC-... will be prevented. This condition will be visually indicated by a flashing auxiliary contact provided the latter is energised. However, if a certain voltage level for the supply of the internal relay is not reached (e.g. in the event of zero voltage), flashing is no longer possible.
- Maintenance
 - Electro-technical functional testing to ensure system availability has to be run regularly, at least every three months, unless other regional or user-specific additional tests are requested.
 - Opening the devices will void all warranty claims.

Condition	Signalling with energised auxiliary contact
ON condition	terminals 14 and 11 are closed, e.g. indicated by red LED
OFF condition	terminals 11 and 12 are closed, e.g. indicated by green LED
undervoltage	terminal 11 is partly interrupted, e.g. indicated by flashing LED
overvoltage	terminal 11 is partly interrupted, e.g. indicated by flashing LED

Connection versions

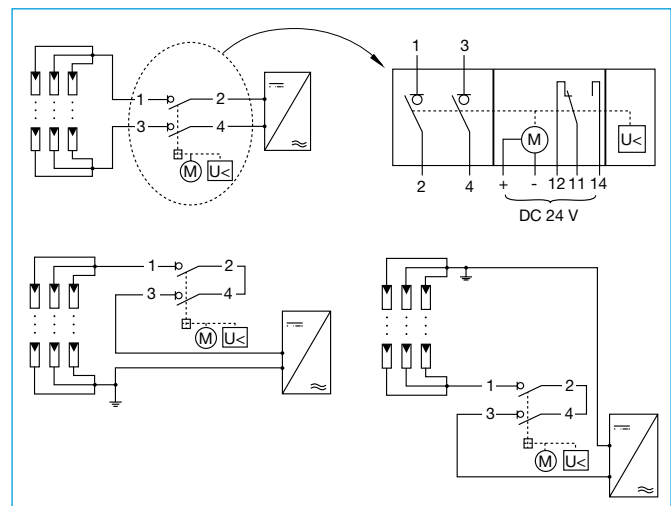

Dimensions

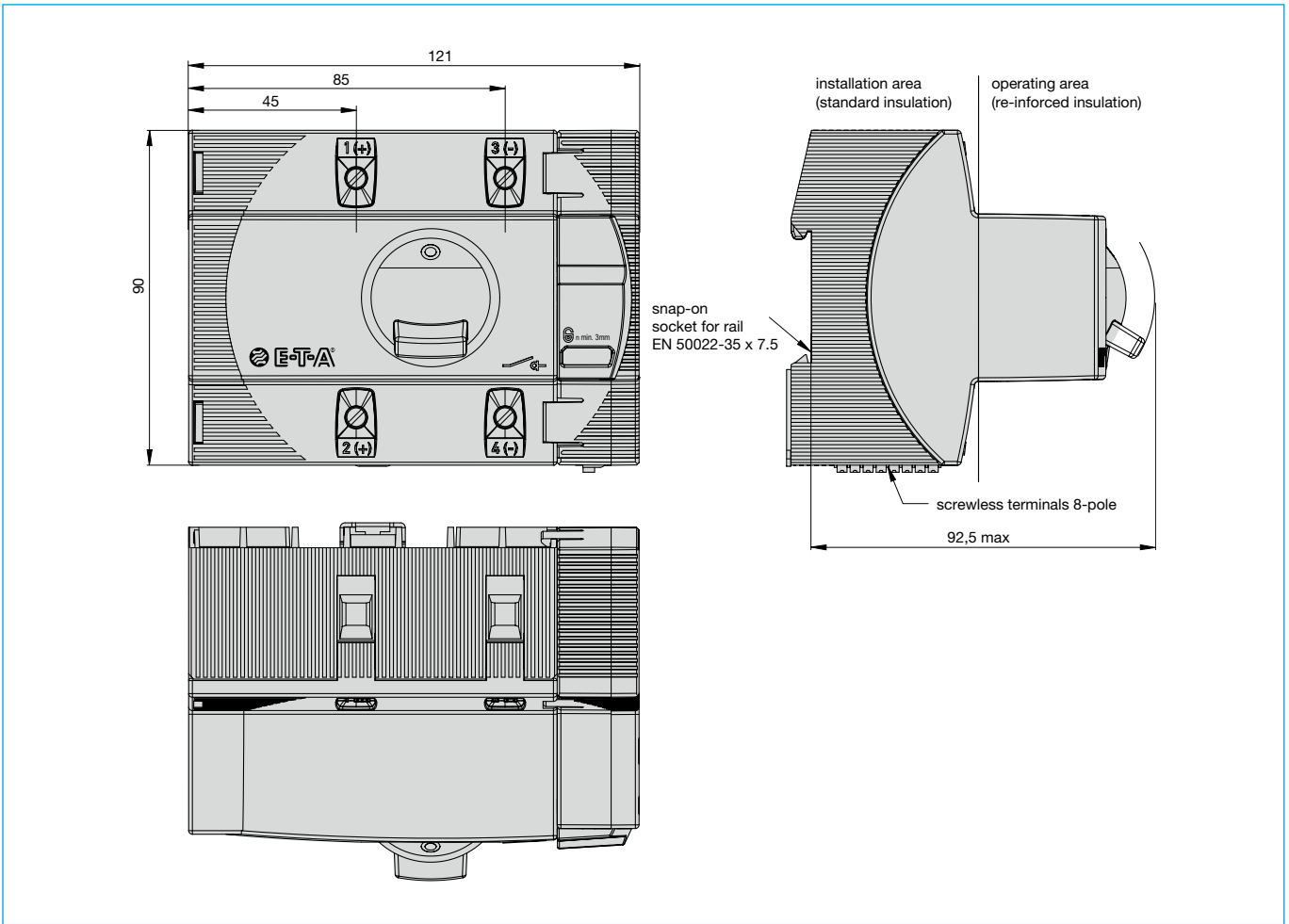

2

Schematic diagram

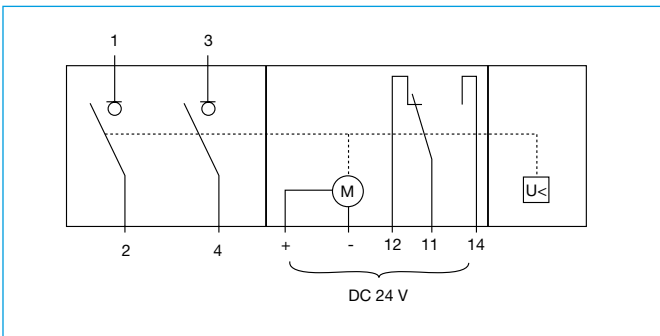

Lock-out feature



System design with PVSEC-...

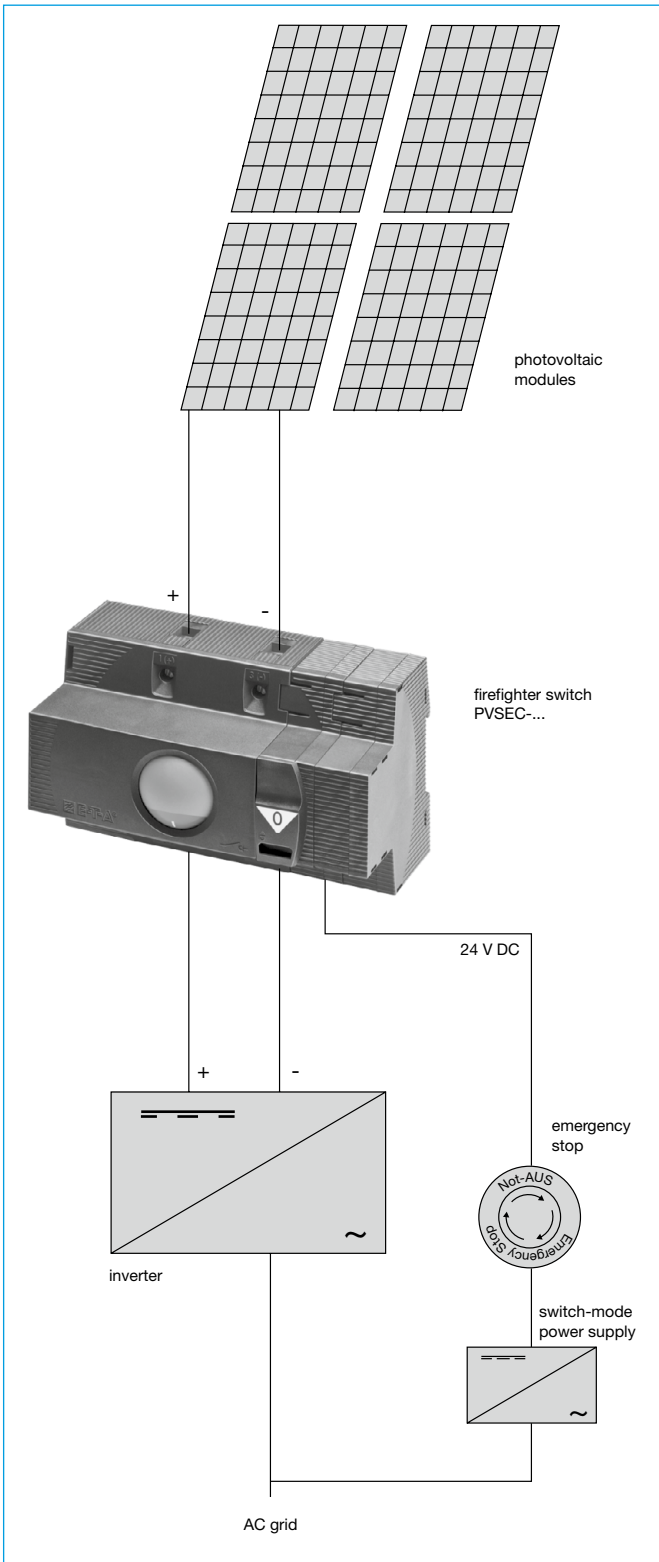

Application example PVSEC-...

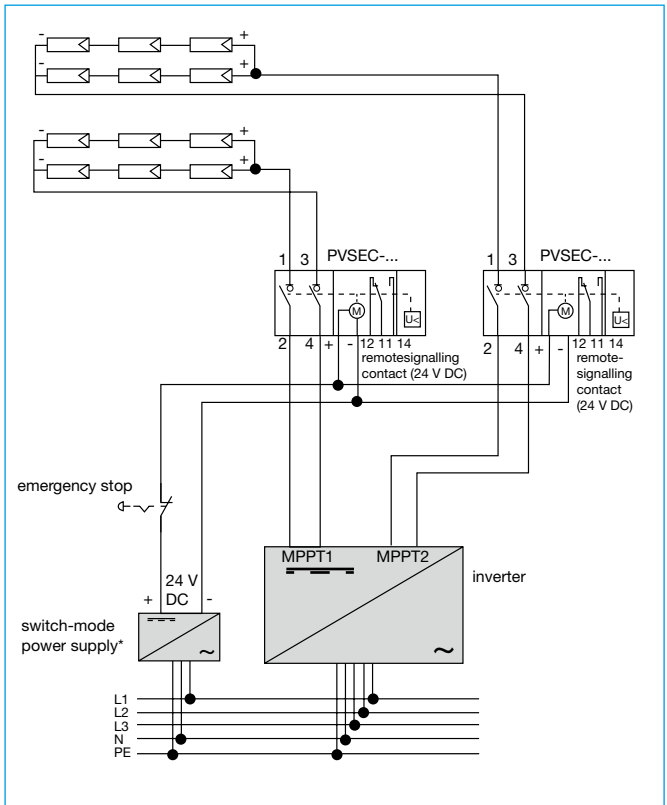

*For suitable switch mode power supplies please see E-T-A product series „SMP ...“

2