

## Features

- Precision supply-voltage monitor
  - 4.63V (PT7M78xxL)
  - 4.38V (PT7M78xxM)
  - 3.08V (PT7M78xxT)
  - 2.93V (PT7M78xxS)
  - 2.63V (PT7M78xxR)
  - 2.32V (PT7M78xxZ)
  - 2.20V (PT7M78xxY)
  - 4.00V (PT7M78xxJ)
  - 2.25V (PT7M78xxK)
  - 2.80V (PT7M78xxG)
- 200ms reset pulse width
- Debounced CMOS-compatible manual-reset input (7811, 7812, 7823, 7825)
- Reset Output Signal for Watchdog and Power Abnormal, Manual Reset
- Reset Push-Pull output (PT7M7809,7811,7823, 7824,7825)
- Reset Open-Drain output (PT7M7803)
- Voltage monitor for power-fail or low battery warning
- Guaranteed  $\overline{\text{RESET}}/\text{RESET}$  valid at  $V_{CC}=1.0V$

## Description

The PT7M78xx family microprocessor (μP) supervisory circuits are targeted to improve reliability and accuracy of power-supply circuitry in μP systems. These devices reduce the complexity and number of components required to monitor power-supply and battery functions.

The main functions are:

1. Asserting reset output during power-up, power-down and brownout conditions for μP system.
2. Watchdog functions
3. Manual reset.

## Applications

- Power-supply circuitry in μP systems
- Networking
- Security System
- Server/Storage
- Embedded System

## Function Comparison Table

	Part No.	$\overline{\text{RESET}}$ output		RESET output (push-pull)	Manual Reset Input	Watchdog Input
		Push-Pull	Open-Drain			
1	PT7M7803	-	√	-	-	-
2	PT7M7809	√	-	-	-	-
3	PT7M7810	-	-	√	-	-
4	PT7M7811	√	-	-	√	-
5	PT7M7812	-	-	√	√	-
6	PT7M7823	√	-	-	√	√
7	PT7M7824	√	-	√	-	√
8	PT7M7825	√	-	√	√	-

## Pin Configuration



## Pin Description

Pin	Type	Description
$\overline{\text{MR}}$	I	<b>Manual-Reset: (CMOS).</b> Active low. Pull low to force a reset. Reset remains asserted for the duration of the Reset Timeout Period after $\overline{\text{MR}}$ transitions from low to high. Leave unconnected or connected to VCC if not used.
VCC	Power	<b>Supply Voltage.</b> Reset is asserted when V <sub>CC</sub> drops below the Reset Threshold Voltage (V <sub>RST</sub> ). Reset remains asserted until V <sub>CC</sub> rises above V <sub>RST</sub> and keep asserted for the duration of the Reset Timeout Period (t <sub>RS</sub> ) once V <sub>CC</sub> rises above V <sub>RST</sub> .
GND	-	<b>Ground Reference</b> for all signals.
WDI	I	<b>Watchdog Input (CMOS).</b> If WDI remains high or low for the duration of the watchdog timeout period (t <sub>WD</sub> ), the internal watchdog timer trigger a reset output. Floating WDI or connecting WDI to a high-impedance three-state buffer disables the watchdog feature. The internal watchdog timer clears whenever reset is asserted or WDI occurs a rising or falling edge.
$\overline{\text{RESET}}$	O	<b>Active-Low Reset Output (Push-Pull or Open-Drain).</b> It goes low when Vcc is below the reset threshold. It remains low for about 200ms after one of the following occurs: Vcc rises above the reset threshold (VRST), the watchdog triggers a reset, or MR goes from low to high.
RESET	O	<b>The inverse of <math>\overline{\text{RESET}}</math>,</b> active high. Whenever $\overline{\text{RESET}}$ is high, RESET is low.
NC	-	<b>No connection.</b>

## Block Diagram

PT7M7823/24/25 Block Diagram



**PT7M7803/09/10/11/12 Block Diagram**



**Maximum Ratings**

Storage Temperature .....	-65°C to +150°C
Ambient Temperature with Power Applied.....	-40°C to +85°C
Supply Voltage to Ground Potential (V <sub>CC</sub> to GND) .....	-0.3V to +7.0V
DC Input Voltage (All inputs except V <sub>CC</sub> and GND).....	-0.3V to V <sub>CC</sub> +0.3V
Open-drain RESET .....	-0.3V to +7.0V
DC Output Current (All outputs) .....	20mA
Power Dissipation .....	320mW (Depend on package)

**Note:**  
Stresses greater than those listed under MAXIMUM RATINGS may cause permanent damage to the device. This is a stress rating only and functional operation of the device at these or any other conditions above those indicated in the operational sections of this specification is not implied. Exposure to absolute maximum rating conditions for extended periods may affect reliability.

**Recommended Operation Conditions**

Sym	Description	Test Conditions	Min.	Typ.	Max.	Unit
V <sub>CC</sub>	Supply Voltage for 78xxL/M/J	-	4.5	5.0	5.5	V
	Supply Voltage for 78xxT/S	-	3.0	3.3	5.5	V
	Supply Voltage for 78xxR/Z/Y/K/G	-	2.7	3.0	5.5	V
V <sub>IH</sub>	Input High Voltage (WDI, MR)	-	0.7V <sub>CC</sub>	-	V <sub>CC</sub>	V
	Input High Voltage for Open-drain RESET	-	0	--	5.5	V
V <sub>IL</sub>	Input Low Voltage	-	-	-	0.3V <sub>CC</sub>	V
T <sub>A</sub>	Operating Temperature	-	-40	-	85	°C

## DC Electrical Characteristics

( $V_{CC} = V_{RN} + 5\%$  to 5.5V,  $T_A = -40 \sim 85^\circ\text{C}$ , unless otherwise noted.)(Note 1)

Symbol	Description	Test Conditions	Min.	Typ.	Max.	Unit	
$V_{CC}$	Operating Voltage Range	-	1.0	-	5.5	V	
$I_{CC}$	Supply Current	$V_{CC} = 5\text{V}$ , No load	7803/09/10/11/12	-	10	30	$\mu\text{A}$
			7823/24/25	-	13	36	
$V_{IH}$	Input High Voltage	Pin: $\overline{\text{MR}}$ , WDI	$0.7V_{CC}$	-	$V_{CC}$	V	
$V_{IL}$	Input Low Voltage	Pin: $\overline{\text{MR}}$ , WDI	-	-	$0.3V_{CC}$	V	
$V_{RST}$	Threshold Voltage(Falling-edge)(Note 2)	$T_A = 25^\circ\text{C}$	78xx	$V_{RN} - 1.5\%$	$V_{RN}$	$V_{RN} + 1.5\%$	V
		$T_A = -40 \sim 85^\circ\text{C}$		$V_{RN} - 2.5\%$	$V_{RN}$	$V_{RN} + 2.5\%$	
$V_{RTH}$	Reset Threshold Hysteresis (Note 2)	$V_{CC}$ varies between $V_{RN} \pm 5\%$	7823/24/25L/M	-	12	-	mV
			7823/24/25 T/S/R/K/Z/Y	-	4	-	
			Others	-	50	-	
$V_{OH}$	Output High Voltage(Except 7823/24/25)	$V_{CC} \geq 4.5\text{V}$ $I_{source} = 800\mu\text{A}$	$V_{CC} - 1.5$	-	-	V	
		$V_{CC} \geq 2.7\text{V}$ $I_{source} = 500\mu\text{A}$	$0.8 \times V_{CC}$	-	-		
		$V_{CC} \geq 1.8\text{V}$ $I_{source} = 150\mu\text{A}$	$0.8 \times V_{CC}$	-	-		
		$V_{CC} \geq 1.0\text{V}$ $I_{source} = 4\mu\text{A}$	$0.8 \times V_{CC}$	-	-		
	Output High Voltage(7823/24/25)	7823/24/25L/M, $V_{CC} = V_{RST}$ $I_{source} = 120\mu\text{A}$	$V_{CC} - 1.5$	-	-	V	
		7823/24/25T/S/R/K, $V_{CC} = V_{RST}$ $I_{source} = 30\mu\text{A}$	$0.8 \times V_{CC}$	-	-	V	
$V_{OL}$	Output Low Voltage	$V_{CC} \geq 4.5\text{V}$ $I_{sink} = 3.2\text{mA}$	-	-	0.4	V	
		$V_{CC} \geq 2.7\text{V}$ $I_{sink} = 1.2\text{mA}$	-	-	0.3		
		$V_{CC} \geq 1.0\text{V}$ $I_{sink} = 100\mu\text{A}$	-	-	0.3		
$I_{LKG}$	Open-Drain Output Leakage Current	$V_{CC} > V_{TH(MAX)}$ for 7803	-	-	1	$\mu\text{A}$	
$I_{WDI}$	Average WDI Input Current (Note 3)	WDI connected to $V_{CC}$ : 5.5V	-	120	160	$\mu\text{A}$	
		WDI connected to GND	-20	-15	-	$\mu\text{A}$	
$I_{source}$	$\overline{\text{RESET}}$ Output Short-Circuit Current (only for PT7M7823/24/25)	PT7M782xL/M, $\overline{\text{RESET}} = 0\text{V}$ , $V_{CC} = 5.5\text{V}$	-	-	800	$\mu\text{A}$	
		PT7M782xT/S/R/K/Z/Y, $\overline{\text{RESET}} = 0\text{V}$ , $V_{CC} = 3.6\text{V}$	-	-	400		
$r$	MR pull-up resistor (internal)	PT7M7811/7812	10	20	40	k $\Omega$	
		PT7M7823/7824/7825	35	52	75		

Note: 1. Parameters of room temperature guaranteed by production test and parameters of full-temperature guaranteed by design.

2. Valid for both  $\overline{\text{RESET}}$  and RESET.  $V_{RST}$  ( $V_{RTH-}$ ) is the Reset threshold voltage when  $V_{CC}$  from high to low level, and  $V_{RTH+}$  is the Reset threshold voltage when  $V_{CC}$  from low to high level.  $V_{RN}$  is nominal reset threshold voltage.

3. WDI is internally serviced within the watchdog period if WDI is left unconnected.

**AC Electrical Characteristics**

Symbol	Description	Test Conditions	Min.	Typ.	Max.	Unit
$t_{RS}$	Reset Pulse Width	$\overline{MR}$ from low to High.	140	200	400	ms
$t_{WD}$	Watchdog Timeout Period	WDI, $\overline{MR}$ tied to $V_{CC}$ , $V_{CC} > V_{RN} + 5\%$ .	1.12	1.6	2.25	s
$t_{MR}$	$\overline{MR}$ Pulse Width	-	200	-	-	ns
$t_{MD}$	$\overline{MR}$ to $\overline{RESET}$ Delay	$V_{CC} = 5V$	-	-	250	ns
$t_{WP}$	WDI Pulse Width	-	150	-	-	ns

**Watchdog Timing Diagram**



## Functional Description

### Reset Output

A microprocessor ( $\mu\text{P}$ ) reset input starts the  $\mu\text{P}$  in a known state. Whenever the  $\mu\text{P}$  is in an unknown state, it should be held in reset. The supervisory circuits assert reset during power-up and prevent code execution errors during power-down or brownout conditions.

On power-up, once  $V_{cc}$  reaches about 1.0V,  $\overline{\text{RESET}}$  is a guaranteed logic low of 0.4V or less. As  $V_{cc}$  rises,  $\overline{\text{RESET}}$  stays low. When  $V_{cc}$  rises above the reset threshold, an internal timer releases  $\overline{\text{RESET}}$  after about 200ms.  $\overline{\text{RESET}}$  pulses low whenever  $V_{cc}$  drops below the reset threshold, i.e. brownout condition. If brownout occurs in the middle of a previously initiated reset pulse, the pulse continues for at least another 200ms. On power-down, once  $V_{cc}$  falls below the reset threshold,  $\overline{\text{RESET}}$  stays low and is guaranteed to be 0.4V or less until  $V_{cc}$  drops below 1.0V. Watchdog Timing Diagram shows the timing relationship.

The active-high RESET output is simply the inverse of the  $\overline{\text{RESET}}$  output, and is guaranteed to be valid with  $V_{cc}$  down to 1.0V.

### Watchdog Timer

The PT7M78xx watchdog circuit monitors the  $\mu\text{P}$  activity. If the  $\mu\text{P}$  does not toggle the watch-dog input (WDI) within 1.6s, reset asserts. As long as reset is asserted or the WDI input is toggled, the watchdog timer will stay clear and will not count. As soon as reset is released, the timer will start counting. WDI input pulses as short as 150ns can be detected.

Disable the watchdog function by leaving WDI unconnected or by three-stating driver connected to WDI.

Do not apply voltage level on DCI over  $V_{cc}$ .

### Manual Reset

The manual-reset input ( $\overline{\text{MR}}$ ) allows reset to be triggered by a push button switch.  $\overline{\text{MR}}$  has an internal pullup resistor, so it can be left open when not used. Do not apply voltage level over  $V_{cc}$ .

## Typical Application Circuit

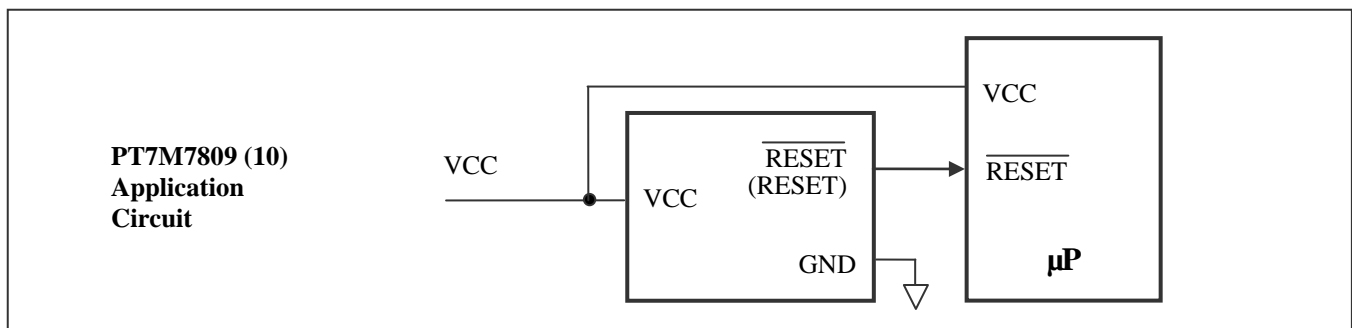





## Mechanical Information

### T (SOT23)

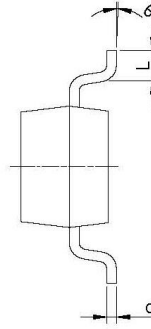
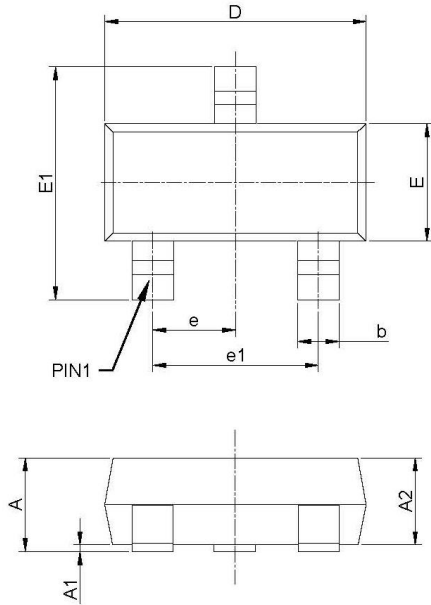

PKG. DIMENSIONS(MM)		
SYMBOL	Min	Max
A	0.75	1.17
A1	0.00	0.15
A2	0.70	1.10
b	0.30	0.51
c	0.08	0.20
D	2.80	3.04
E	1.20	1.40
E1	2.10	2.64
e	0.95 BSC	
e1	1.90 BSC	
L	0.30	0.60
θ	0°	8°

**Notes:**

1. Comply with TO-236H/AA, except A1 Min, A2 Max, b Max and L Min.
2. PACKAGE OUTLINE DIMENSIONS DO NOT INCLUDE MOLD FLASH AND METAL BURR



DATE: 03/29/16

DESCRIPTION: 3-Pin, Small Outline Transistor Plastic Package (SOT23)

PACKAGE CODE: T (T3)

DOCUMENT CONTROL#: PD-2142

REVISION: A

16-0079

**C (SC70)**

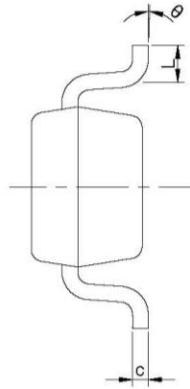
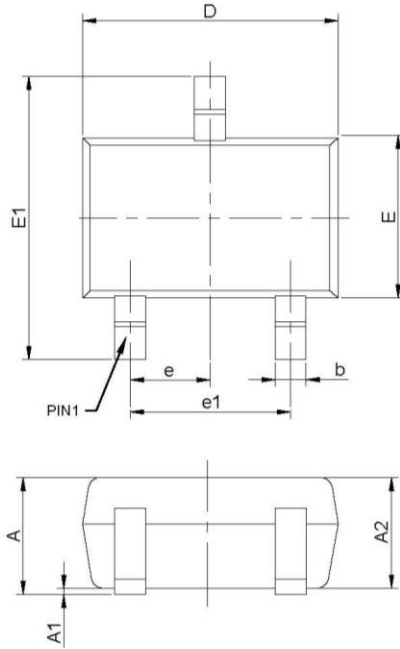

PKG. DIMENSIONS(MM)		
SYMBOL	Min	Max
A	-	1.10
A1	0.00	0.10
A2	0.70	1.00
b	0.15	0.40
c	0.08	0.22
D	1.80	2.20
E	1.10	1.40
E1	1.75	2.45
e	0.65 BSC	
e1	1.30 BSC	
L	0.26	0.46
theta	0°	8°

**Note:**

1. Comply with MO-203C, except b Max, D Min, D Max, E1 Min and E1 Max.
2. PACKAGE OUTLINE DIMENSIONS DO NOT INCLUDE MOLD FLASH AND METAL BURR



DATE: 03/29/16

DESCRIPTION: 3-Pin, SOT323 (SC70)

PACKAGE CODE: C (C3)

DOCUMENT CONTROL#: PD-2147

REVISION: A

16-0077

**PT7M7803/7809-7812/7823-7825**

TA (SOT23)

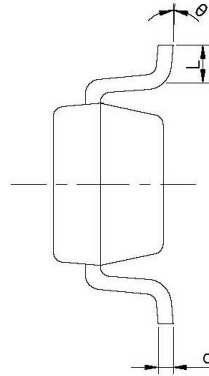
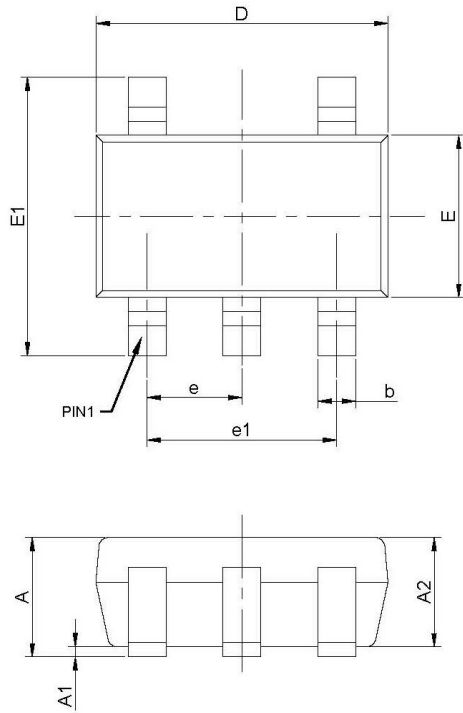

PKG. DIMENSIONS(MM)		
SYMBOL	Min	Max
A	-	1.45
A1	0.00	0.15
A2	0.90	1.30
b	0.30	0.50
c	0.08	0.22
D	2.75	3.05
E	1.45	1.75
E1	2.60	3.00
e	0.95 BSC	
e1	1.90 BSC	
L	0.30	0.60
θ	0°	8°

Note:

1. Ref: JEDEC MO-178C/AA
2. PACKAGE OUTLINE DIMENSIONS DO NOT INCLUDE MOLD FLASH AND METAL BUR

	DATE: 03/29/16
	DESCRIPTION: 5-Pin, Small Outline Transistor Plastic Package (SOT23)
	PACKAGE CODE: TA (TA5)
	DOCUMENT CONTROL #: PD-2144
	REVISION: A

16-0081

**PT7M7803/7809-7812/7823-7825**

TB (SOT143)

PKG. DIMENSIONS(MM)		
SYMBOL	Min	Max
A	0.80	1.22
A1	0.00	0.15
A2	0.75	1.07
b	0.30	0.50
b1	0.75	0.90
c	0.08	0.20
D	2.80	3.04
d	0.20 BSC	
E	1.20	1.40
E1	2.10	2.64
e	1.92 BSC	
L	0.30	0.60
θ	0°	8°

**Note:**  
1. Comply with TO-253D/AA, except A1 Min, b1 Min, b1 Max, and L Min.  
2. PACKAGE OUTLINE DIMENSIONS DO NOT INCLUDE MOLD FLASH AND METAL BURR

<b>PERICOM</b> Enabling Serial Connectivity	DATE: 03/29/16
DESCRIPTION: 4-Pin, SOT143	
PACKAGE CODE: TB (TB4)	
DOCUMENT CONTROL#: PD-2146	REVISION: A

16-0083

Note: For latest package info, please check: <http://www.pericom.com/support/packaging/packaging-mechanicals-and-thermal-characteristics/>

## Ordering Information

Part Number	Package Code	Package
PT7M7803XTEX	T	3-Pin, Small Outline Transistor Plastic (SOT23), Tape & Reel
PT7M7809XTEX	T	3-Pin, Small Outline Transistor Plastic (SOT23), Tape & Reel
PT7M7810XTEX	T	3-Pin, Small Outline Transistor Plastic (SOT23), Tape & Reel
PT7M7803XC3EX	C3	3-Pin, SOT323 (SC70), Tape & Reel
PT7M7809XC3EX	C3	3-Pin, SOT323 (SC70), Tape & Reel
PT7M7810XC3EX	C3	3-Pin, SOT323 (SC70), Tape & Reel
PT7M7811XTAEX	TA	5-Pin, Small Outline Transistor Plastic Package (SOT23), Tape & Reel
PT7M7812XTAEX	TA	5-Pin, Small Outline Transistor Plastic Package (SOT23), Tape & Reel
PT7M7823XTAEX	TA	5-Pin, Small Outline Transistor Plastic Package (SOT23), Tape & Reel
PT7M7824XTAEX	TA	5-Pin, Small Outline Transistor Plastic Package (SOT23), Tape & Reel
PT7M7825XTAEX	TA	5-Pin, Small Outline Transistor Plastic Package (SOT23), Tape & Reel
PT7M7811XTBEX	TB	4-Pin (SOT143), Tape & Reel
PT7M7812XTBEX	TB	4-Pin (SOT143), Tape & Reel
*PT7M7809XUWF	UWF	Wafer form

**Note:**

- Thermal characteristics can be found on the company web site at [www.pericom.com/packaging/](http://www.pericom.com/packaging/)
- E = Pb-free and Green
- Adding X Suffix= Tape/Reel
- “\*\*” for UWF package, please check the storage with related sales.

## Suffix: X—Monitored Voltage

X	L	M	T	S	R	Z	Y	J	K	G
Reset Threshold (V)	4.63	4.38	3.08	2.93	2.63	2.32	2.20	4.00	2.25	2.80

**PT7M7803/7809-7812/7823-7825**

**Marking Information**



Code	Description
1 2	Part Number
3	Year
4	Work Week
●	Only for PT7M7809M

**Part Number Code**

Code 1 2	Part No	Code 1 2	Part No	Code 1 2	Part No	Code 1 2	Part No
AA	PT7M7809L	AO	PT7M7811L	BC	PT7M7803L	BQ	PT7M7824L
AB	PT7M7809M	AP	PT7M7811M	BD	PT7M7803M	BR	PT7M7824M
AC	PT7M7809T	AQ	PT7M7811T	BE	PT7M7803T	BS	PT7M7824T
AD	PT7M7809S	AR	PT7M7811S	BF	PT7M7803S	BT	PT7M7824S
AE	PT7M7809R	AS	PT7M7811R	BG	PT7M7803R	BU	PT7M7824R
AF	PT7M7809Z	AT	PT7M7811Z	BH	PT7M7803Z	BV	PT7M7824Z
AG	PT7M7809Y	AU	PT7M7811Y	BI	PT7M7803Y	BW	PT7M7824Y
jm	PT7M7809J	sf	PT7M7811J	sc	PT7M7803J	si	PT7M7824J
pE	PT7M7809G					mQ	PT7M7824K
AH	PT7M7810L	AV	PT7M7812L	BJ	PT7M7823L	BX	PT7M7825L
AI	PT7M7810M	AW	PT7M7812M	BK	PT7M7823M	BY	PT7M7825M
AJ	PT7M7810T	AX	PT7M7812T	BL	PT7M7823T	BZ	PT7M7825T
AK	PT7M7810S	AY	PT7M7812S	BM	PT7M7823S	CA	PT7M7825S
AL	PT7M7810R	AZ	PT7M7812R	BN	PT7M7823R	CB	PT7M7825R
AM	PT7M7810Z	BA	PT7M7812Z	BO	PT7M7823Z	CC	PT7M7825Z
AN	PT7M7810Y	BB	PT7M7812Y	BP	PT7M7823Y	CD	PT7M7825Y
se	PT7M7810J	sg	PT7M7812J	sh	PT7M7823J	sj	PT7M7825J
				mP	PT7M7823K		

**IMPORTANT NOTICE**

DIODES INCORPORATED MAKES NO WARRANTY OF ANY KIND, EXPRESS OR IMPLIED, WITH REGARDS TO THIS DOCUMENT, INCLUDING, BUT NOT LIMITED TO, THE IMPLIED WARRANTIES OF MERCHANTABILITY AND FITNESS FOR A PARTICULAR PURPOSE (AND THEIR EQUIVALENTS UNDER THE LAWS OF ANY JURISDICTION).

Diodes Incorporated and its subsidiaries reserve the right to make modifications, enhancements, improvements, corrections or other changes without further notice to this document and any product described herein. Diodes Incorporated does not assume any liability arising out of the application or use of this document or any product described herein; neither does Diodes Incorporated convey any license under its patent or trademark rights, nor the rights of others. Any Customer or user of this document or products described herein in such applications shall assume all risks of such use and will agree to hold Diodes Incorporated and all the companies whose products are represented on Diodes Incorporated website, harmless against all damages.

Diodes Incorporated does not warrant or accept any liability whatsoever in respect of any products purchased through unauthorized sales channel. Should Customers purchase or use Diodes Incorporated products for any unintended or unauthorized application, Customers shall indemnify and hold Diodes Incorporated and its representatives harmless against all claims, damages, expenses, and attorney fees arising out of, directly or indirectly, any claim of personal injury or death associated with such unintended or unauthorized application.

Products described herein may be covered by one or more United States, international or foreign patents pending. Product names and markings noted herein may also be covered by one or more United States, international or foreign trademarks.

This document is written in English but may be translated into multiple languages for reference. Only the English version of this document is the final and determinative format released by Diodes Incorporated.

**LIFE SUPPORT**

Diodes Incorporated products are specifically not authorized for use as critical components in life support devices or systems without the express written approval of the Chief Executive Officer of Diodes Incorporated. As used herein:

A. Life support devices or systems are devices or systems which:

1. are intended to implant into the body, or
2. support or sustain life and whose failure to perform when properly used in accordance with instructions for use provided in the labeling can be reasonably expected to result in significant injury to the user.

B. A critical component is any component in a life support device or system whose failure to perform can be reasonably expected to cause the failure of the life support device or to affect its safety or effectiveness.

Customers represent that they have all necessary expertise in the safety and regulatory ramifications of their life support devices or systems, and acknowledge and agree that they are solely responsible for all legal, regulatory and safety-related requirements concerning their products and any use of Diodes Incorporated products in such safety-critical, life support devices or systems, notwithstanding any devices- or systems-related information or support that may be provided by Diodes Incorporated. Further, Customers must fully indemnify Diodes Incorporated and its representatives against any damages arising out of the use of Diodes Incorporated products in such safety-critical, life support devices or systems.

Copyright © 2016, Diodes Incorporated

[www.diodes.com](http://www.diodes.com)