

Features

- High accuracy: $\pm 2\%$ (25 °C)
- Low power consumption: 0.6 μ A @ 3V V_{CC}
- Detecting voltage range: 1.8 to 5V in 100mV increments
- Operating voltage range: 1.2V ~ 5.5V
- Operating temperature range: -40 °C to + 85 °C
- Detecting voltage accuracy over temperature: $\pm 2.5\% \times$ TYP
- Output configuration: N-channel open drain or CMOS
- Reset timeout period at least 120ms

Description

The PT7M64xx series are μ P supervisory circuits with a minimum reset timeout period of 120ms. Each circuit includes a precise bandgap reference; a comparator, a reset timeout circuit, internally trimmed resistor networks that set specified trip thresholds, and an internal 5% threshold hysteresis circuit (see the *Block Diagram*). Output is asserted when V_{CC} falls below the internal V_{TH}. and remains asserted until V_{CC} rises above V_{TH+} (V_{TH+} = V_{TH} × 1.05) after a reset timeout period. These devices provide excellent circuit reliability and low cost by eliminating external components and adjustments when monitoring normal systems voltage from +1.8V to +5V in 100mV increments. The series are voltage detectors with a propagation delay of 35 μ s.

The family is available with four output stage options: push-pull with active-low output, push-pull with active-high output, open drain with active-low output and bidirection port with active-low output and pushbutton reset input. These devices specified over the -40 °C to +85 °C temperature range.

Table 1. Function comparison

Item	Part No.	Reset Output				Reset bi-direction	Threshold
		Open-Drain		Push-Pull			
		Active high	Active low	Active high	Active low		
1	PT7M64xxCL	-	-	-	√	-	1.8V to 5.0V in 100mV increments
2	PT7M64xxCH	-	-	√	-	-	
3	PT7M64xxNL	-	√	-	-	-	

Pin Configuration

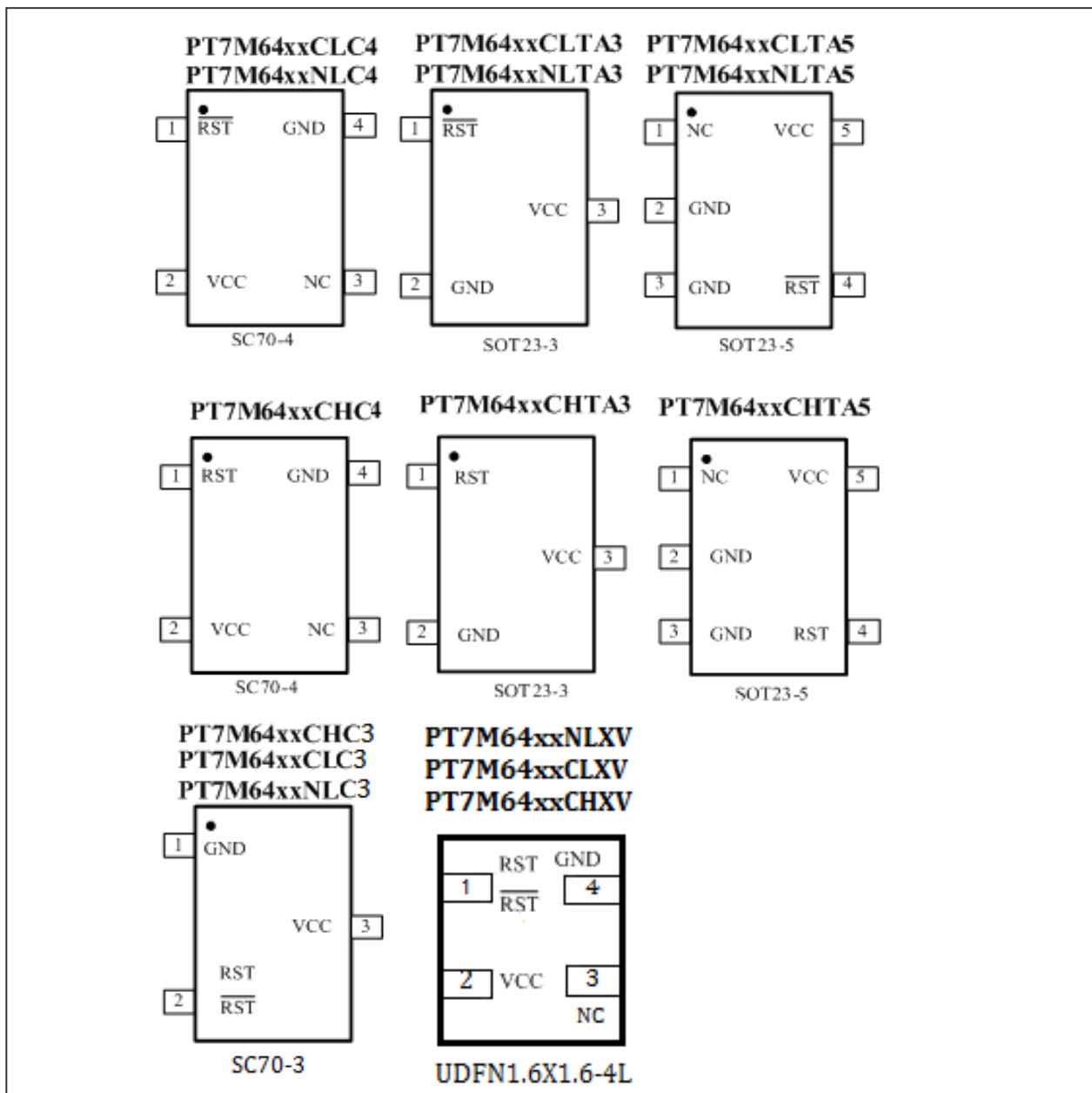

Pin Description

Name	Type	Description
$\overline{\text{RST}}$	O	Reset Output (PT7M64xxCL/NL/BL/NLL): $\overline{\text{RST}}$ is asserted when V_{CC} drops below voltage threshold V_{TH} : Active low. For PT7M64xxBL, RST is also pushbutton reset input
RST	O	Reset Output (PT7M64xxCH): RST is asserted when V_{CC} drops below voltage threshold V_{TH} : Active high.
GND	P	Ground
V_{CC}	P	Supply Voltage

Block Diagram

Block Diagram of PT7M64xxCL/CH

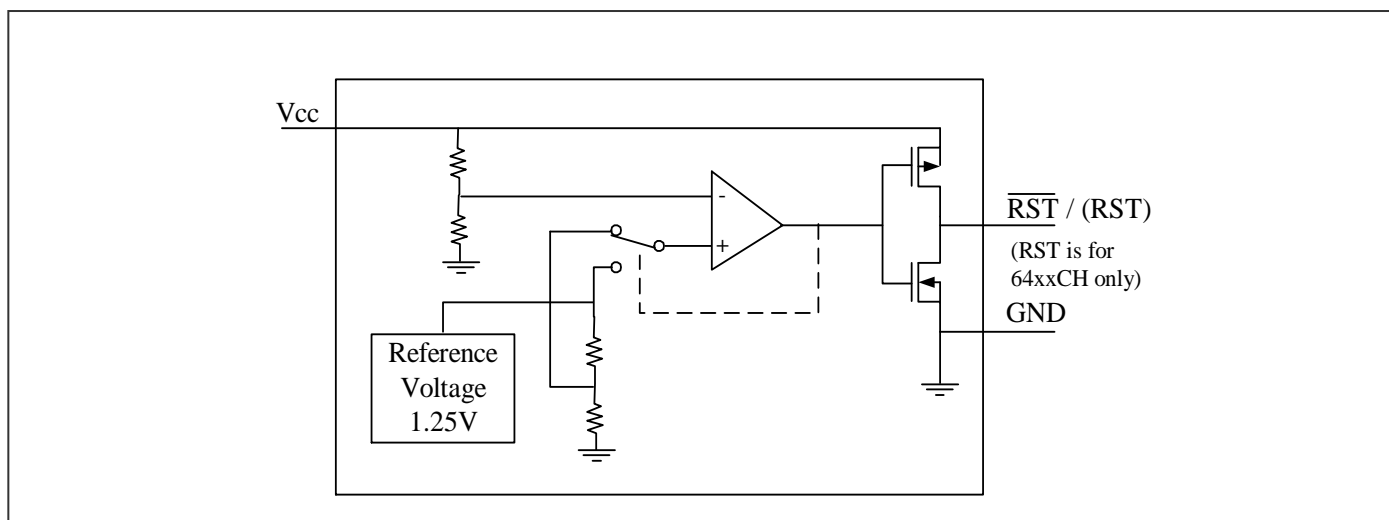

Block Diagram of PT7M64xxNL

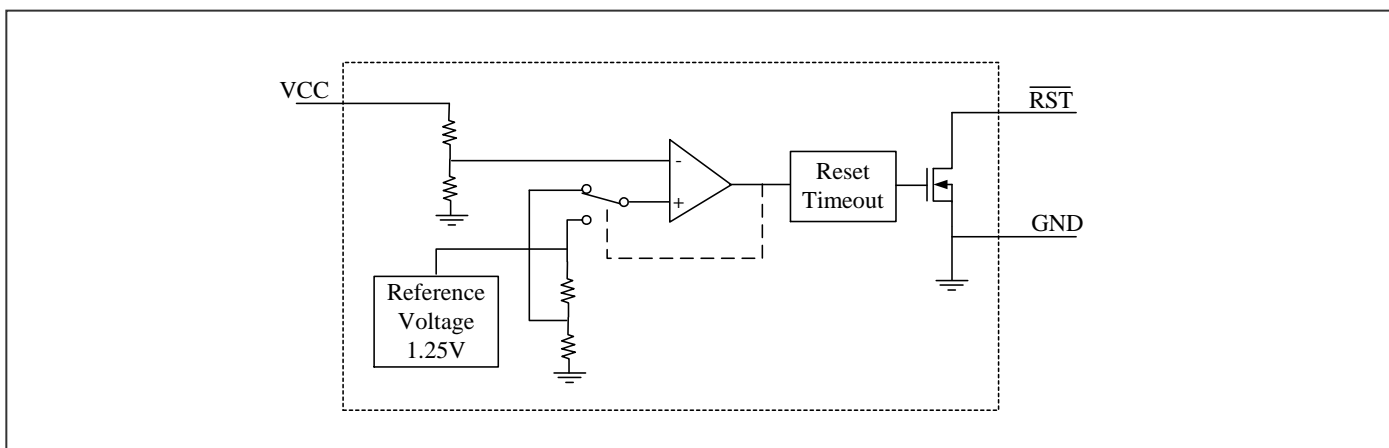

Maximum Ratings

Storage Temperature	-65 °C to +150 °C
Ambient Temperature with Power Applied	-40 °C to +85 °C
Supply Voltage to Ground Potential (V _{CC} to GND)	-0.3V to +6.0V
DC Input Voltage (All inputs except V _{CC} and GND).....	-0.3V to V _{CC} +0.3V
DC Output Current (All outputs)	20mA
ESD(HBM) for 64xxNL/NLL.....	1 KV
ESD(HBM) for 64xxCL/CH/BL.....	2KV
Power Dissipation	320mW
	(Depend on package)

Note:

Stresses greater than those listed under MAXIMUM RATINGS may cause permanent damage to the device. This is a stress rating only and functional operation of the device at these or any other conditions above those indicated in the operational sections of this specification is not implied. Exposure to absolute maximum rating conditions for extended periods may affect reliability.

DC Electrical Characteristics

(V_{CC} = 1.2V to 5.5V, T_A = -40~85 °C, unless otherwise noted. Typical values are at T_A = +25 °C)

Description		Sym	Test Conditions	Min	Typ	Max	Unit
Supply Voltage		V _{CC}	T _A = 0~70 °C	1.0	-	5.5	V
			T _A = -40~85 °C	1.2	-	5.5	
Supply Current		I _{CC}	V _{CC} = 3V. No load.	-	0.6	1.2	μA
			V _{CC} = 5V. No load.	-	0.9	2.0	μA
Output Driving	Output high (Push-Pull only)	V _{OH}	V _{CC} ≥ 1.8V, I _{source} = 1mA	0.8 × V _{CC}	-	-	V
			V _{CC} ≥ 2.5V, I _{source} = 3mA	0.8 × V _{CC}	-	-	
			V _{CC} ≥ 4.5V, I _{source} = 8mA	0.8 × V _{CC}	-	-	
	Output low	V _{OL}	V _{CC} ≥ 1.2V, I _{sink} = 1mA	-	-	0.3	V
			V _{CC} ≥ 2.5V, I _{sink} = 4mA	-	-	0.3	
			V _{CC} ≥ 4.5V, I _{sink} = 9mA	-	-	0.4	
Open-Drain Output Leakage Current		I _{LKG}	-	-	-	1	μA
Voltage Threshold*		V _{TH-}	+25°C	(V _{TH-}) × 0.985	V _{TH-}	(V _{TH-}) × 1.015	V
			-40°C~85°C	(V _{TH-}) × 0.975	V _{TH-}	(V _{TH-}) × 1.025	
		V _{TH+}	+25°C	(V _{TH+}) × 0.985	V _{TH+}	(V _{TH+}) × 1.015	
			-40°C~85°C	(V _{TH+}) × 0.975	V _{TH+}	(V _{TH+}) × 1.025	
Voltage threshold Hysteresis		V _{HYST}	V _{HYST} = [(V _{TH+}) - (V _{TH-})] / (V _{TH-}) × 100%	3	4.5	6	%
Pushbutton Detect		P _{BDV}	-40°C~85°C, V _{CC} = 5V	0.7	-	1.2	V
Internal Pull-Up Resistor		R _P	-	3.75	5	6.25	kΩ

* V_{TH+} = 1.05 × V_{TH-}. V_{TH-} is V_{CC} dropping from high to low voltage. V_{TH+} is V_{CC} rising from low to high voltage.

AC Electrical Characteristics

Timing Diagram

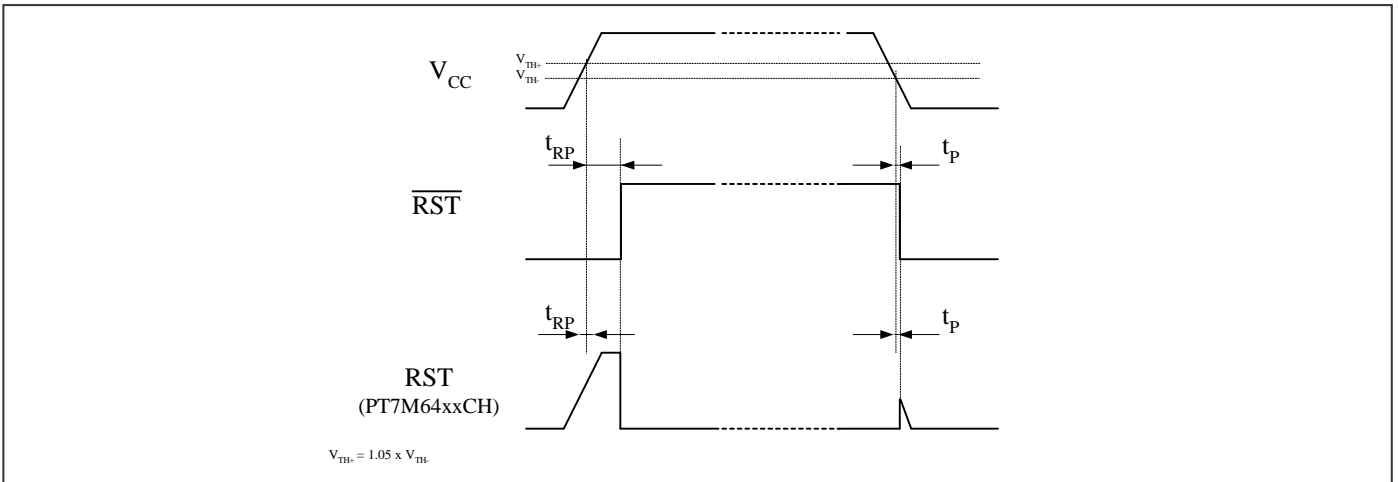

($V_{CC} = 1.2V$ to $5.5V$, $T_A = -40 \sim 85 \text{ } ^\circ\text{C}$, unless otherwise noted. Typical values are at $T_A = +25 \text{ } ^\circ\text{C}$)

Sym	Description	Test Conditions	Min	Typ	Max	Unit
t_{RP}	Timeout Period	$T_A = +25 \text{ } ^\circ\text{C}$	120	260	430	ms
t_p	Delay	-	-	35	-	μs

Typical Operation Circuit

PT7M64xxNL Application Example

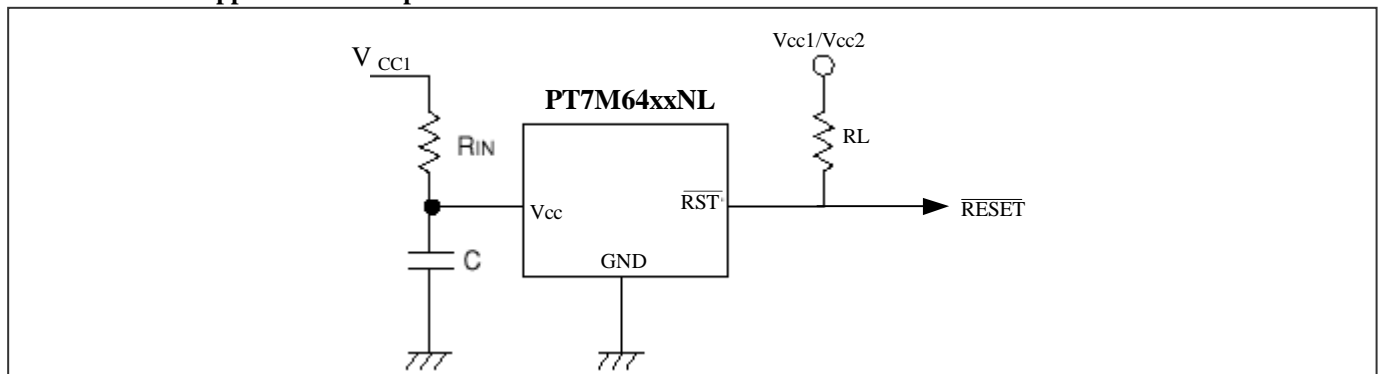

For typical application, R_L could be $100\text{k}\Omega$, R_{IN} less than $10\text{k}\Omega$ and that C more than $0.1\mu\text{F}$.

Mechanical Information

TA3 (SOT23)

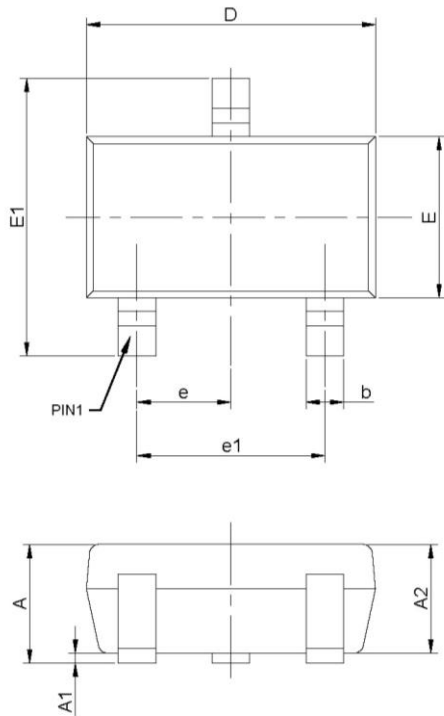

PKG. DIMENSIONS(MM)		
SYMBOL	Min	Max
A	-	1.45
A1	0.00	0.15
A2	0.90	1.30
b	0.30	0.50
c	0.08	0.22
D	2.75	3.10
E	1.45	1.75
E1	2.60	3.00
e	0.95 BSC	
e1	1.90 BSC	
L	0.30	0.60
θ	0°	8°

Note:

1. Comply with MO-178C, except D Max.
2. PACKAGE OUTLINE DIMENSIONS DO NOT INCLUDE MOLD FLASH AND METAL BURR



DATE: 03/29/16

DESCRIPTION: 3-Pin, Small Outline Transistor Plastic Package (SOT23)

PACKAGE CODE: TA (TA3)

DOCUMENT CONTROL #: PD-2143

REVISION: A

16-0080

TA5 (SOT23)

PKG. DIMENSIONS(MM)		
SYMBOL	Min	Max
A	-	1.45
A1	0.00	0.15
A2	0.90	1.30
b	0.30	0.50
c	0.08	0.22
D	2.75	3.05
E	1.45	1.75
E1	2.60	3.00
e	0.95 BSC	
e1	1.90 BSC	
L	0.30	0.60
θ	0°	8°

Note:
1. Ref: JEDEC MO-178C/AA
2. PACKAGE OUTLINE DIMENSIONS DO NOT INCLUDE MOLD FLASH AND METAL BUR

PERICOM
Enabling Serial Connectivity

DATE: 03/29/16

DESCRIPTION: 5-Pin, Small Outline Transistor Plastic Package (SOT23)

PACKAGE CODE: TA (TA5)

DOCUMENT CONTROL #: PD-2144

REVISION: A

16-0081

C4 (SC70)

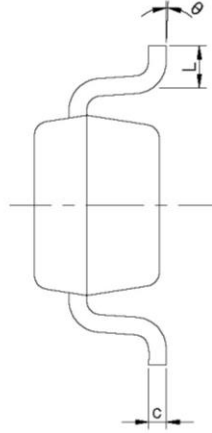
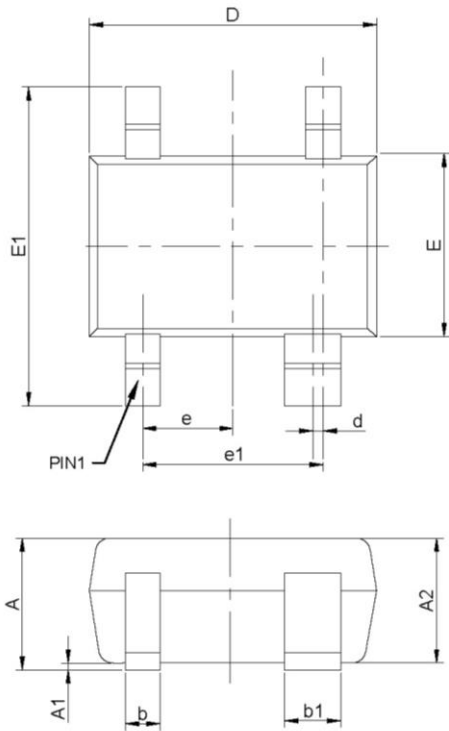

PKG. DIMENSIONS(MM)		
SYMBOL	Min	Max
A	0.90	1.10
A1	0.00	0.10
A2	0.90	1.00
b	0.25	0.40
b1	0.35	0.50
c	0.08	0.15
D	2.00	2.20
d	0.05 TYP	
E	1.15	1.35
E1	2.15	2.45
e	0.65 TYP	
e1	1.20	1.40
L	0.26	0.46
θ	0°	8°

Notes:

1. Ref. JEDEC MO-203B



DATE: 06/18/13

DESCRIPTION: 4-Pin, SOT343 (SC70)

PACKAGE CODE: C (C4)

DOCUMENT CONTROL#: PD-2148

REVISION: --

13-0187

C3 (SC70)

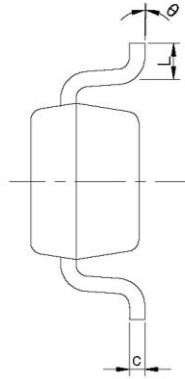
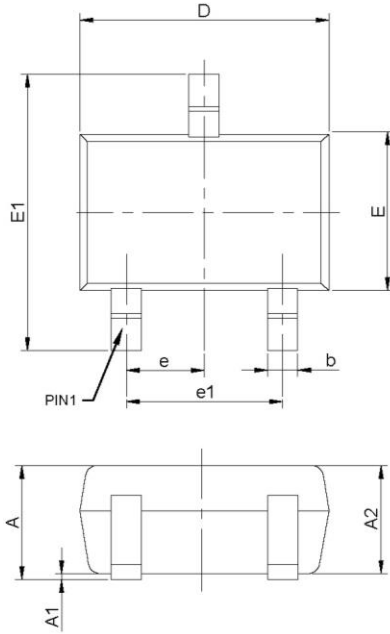

PKG. DIMENSIONS(MM)		
SYMBOL	Min	Max
A	-	1.10
A1	0.00	0.10
A2	0.70	1.00
b	0.15	0.40
c	0.08	0.22
D	1.80	2.20
E	1.10	1.40
E1	1.75	2.45
e	0.65 BSC	
e1	1.30 BSC	
L	0.26	0.46
θ	0°	8°

Note:

1. Comply with MO-203C, except b Max, D Min, D Max, E1 Min and E1 Max.
2. PACKAGE OUTLINE DIMENSIONS DO NOT INCLUDE MOLD FLASH AND METAL BURR



DATE: 03/29/16

DESCRIPTION: 3-Pin, SOT323 (SC70)

PACKAGE CODE: C (C3)

DOCUMENT CONTROL#: PD-2147

REVISION: A

16-0077

XV (UDFN1.6x1.6-4L)

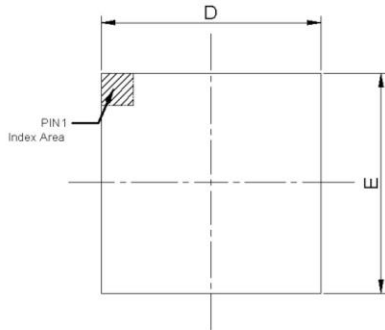

TOP VIEW

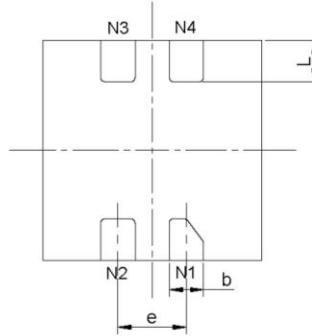

BOTTOM VIEW

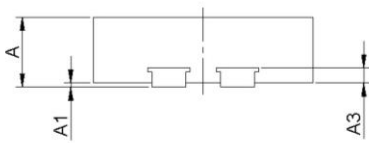

SIDE VIEW

PKG. DIMENSIONS(MM)		
SYMBOL	Min	Max
A	0.45	0.55
A1	0.00	0.05
A3	0.11 REF	
D	1.55	1.65
E	1.55	1.65
b	0.20	0.30
e	0.50 TYP	
L	0.25	0.35

Notes:
1. Ref. JEDEC MO-287A

	DATE: 06/18/13
	DESCRIPTION: 4-Pin, UDFN, 1.6X1.6, MIS
	PACKAGE CODE: XV (XV4)
	DOCUMENT CONTROL #: PD-2130
	REVISION: --

13-0169

For latest package info.

please check: <http://www.diodes.com/design/support/packaging/pericom-packaging/packaging-mechanicals-and-thermal-characteristics/>

Ordering Information

Part Number	Package Code	Package
PT7M64xxCLTA3E	TA3	3-Pin, Small Outline Transistor Plastic Package (SOT23)
PT7M64xxCLTA5E	TA5	5-Pin, Small Outline Transistor Plastic Package (SOT23)
PT7M64xxCLC3E	C3	3-Pin, SOT323 (SC70)
PT7M64xxCLC4E	C4	4-Pin, SOT343 (SC70)
*PT7M64xxCHTA3E	TA3	3-Pin, Small Outline Transistor Plastic Package (SOT23)
*PT7M64xxCHTA5E	TA5	5-Pin, Small Outline Transistor Plastic Package (SOT23)
*PT7M64xxCHC3E	C3	3-Pin, SOT323 (SC70)
*PT7M64xxCHC4E	C4	4-Pin, SOT343 (SC70)
PT7M64xxNLTA3E	TA3	3-Pin, Small Outline Transistor Plastic Package (SOT23)
PT7M64xxNLTA5E	TA5	5-Pin, Small Outline Transistor Plastic Package (SOT23)
PT7M64xxNLC3E	C3	3-Pin, SOT323 (SC70)
PT7M64xxNLC4E	C4	4-Pin, SOT343 (SC70)
PT7M64xxNLXV4E	XV	4-Pin, 1.6x1.6, MIS (UDFN)
PT7M64xxCLXV4E	XV	4-Pin, 1.6x1.6, MIS (UDFN)
*PT7M64xxCHXV4E	XV	4-Pin, 1.6x1.6, MIS (UDFN)

Note:

- “xx” refer to voltage range, see below table 1.
- E = Pb-free or Pb-free and Green
- Adding X Suffix= Tape/Reel
- Contact Pericom for availability.
- “*” for CH part, please check the storage with related sales.

Table.2 Suffix “xx” definition of PT7M64xx

Suffix xx	V _{TH} (V)	Suffix xx	V _{TH} (V)	Suffix xx	V _{TH} (V)	Suffix xx	V _{TH} (V)	Suffix xx	V _{TH} (V)
18	1.8	25	2.5	32	3.2	39	3.9	46	4.6
19	1.9	26	2.6	33	3.3	40	4.0	47	4.7
20	2.0	27	2.7	34	3.4	41	4.1	48	4.8
21	2.1	28	2.8	35	3.5	42	4.2	49	4.9
22	2.2	29	2.9	36	3.6	43	4.3	50	5.0
23	2.3	30	3.0	37	3.7	44	4.4		
24	2.4	31	3.1	38	3.8	45	4.5		

IMPORTANT NOTICE

DIODES INCORPORATED MAKES NO WARRANTY OF ANY KIND, EXPRESS OR IMPLIED, WITH REGARDS TO THIS DOCUMENT, INCLUDING, BUT NOT LIMITED TO, THE IMPLIED WARRANTIES OF MERCHANTABILITY AND FITNESS FOR A PARTICULAR PURPOSE (AND THEIR EQUIVALENTS UNDER THE LAWS OF ANY JURISDICTION).

Diodes Incorporated and its subsidiaries reserve the right to make modifications, enhancements, improvements, corrections or other changes without further notice to this document and any product described herein. Diodes Incorporated does not assume any liability arising out of the application or use of this document or any product described herein; neither does Diodes Incorporated convey any license under its patent or trademark rights, nor the rights of others. Any Customer or user of this document or products described herein in such applications shall assume all risks of such use and will agree to hold Diodes Incorporated and all the companies whose products are represented on Diodes Incorporated website, harmless against all damages.

Diodes Incorporated does not warrant or accept any liability whatsoever in respect of any products purchased through unauthorized sales channel.

Should Customers purchase or use Diodes Incorporated products for any unintended or unauthorized application, Customers shall indemnify and hold Diodes Incorporated and its representatives harmless against all claims, damages, expenses, and attorney fees arising out of, directly or indirectly, any claim of personal injury or death associated with such unintended or unauthorized application.

Products described herein may be covered by one or more United States, international or foreign patents pending. Product names and markings noted herein may also be covered by one or more United States, international or foreign trademarks.

This document is written in English but may be translated into multiple languages for reference. Only the English version of this document is the final and determinative format released by Diodes Incorporated.

LIFE SUPPORT

Diodes Incorporated products are specifically not authorized for use as critical components in life support devices or systems without the express written approval of the Chief Executive Officer of Diodes Incorporated. As used herein:

A. Life support devices or systems are devices or systems which:

1. are intended to implant into the body, or
2. support or sustain life and whose failure to perform when properly used in accordance with instructions for use provided in the labeling can be reasonably expected to result in significant injury to the user.

B. A critical component is any component in a life support device or system whose failure to perform can be reasonably expected to cause the failure of the life support device or to affect its safety or effectiveness.

Customers represent that they have all necessary expertise in the safety and regulatory ramifications of their life support devices or systems, and acknowledge and agree that they are solely responsible for all legal, regulatory and safety-related requirements concerning their products and any use of Diodes Incorporated products in such safety-critical, life support devices or systems, notwithstanding any devices- or systems-related information or support that may be provided by Diodes Incorporated. Further, Customers must fully indemnify Diodes Incorporated and its representatives against any damages arising out of the use of Diodes Incorporated products in such safety-critical, life support devices or systems.

Copyright © 2016, Diodes Incorporated
www.diodes.com

SOT-23/SC-70 Package Top Marking Instruction

