

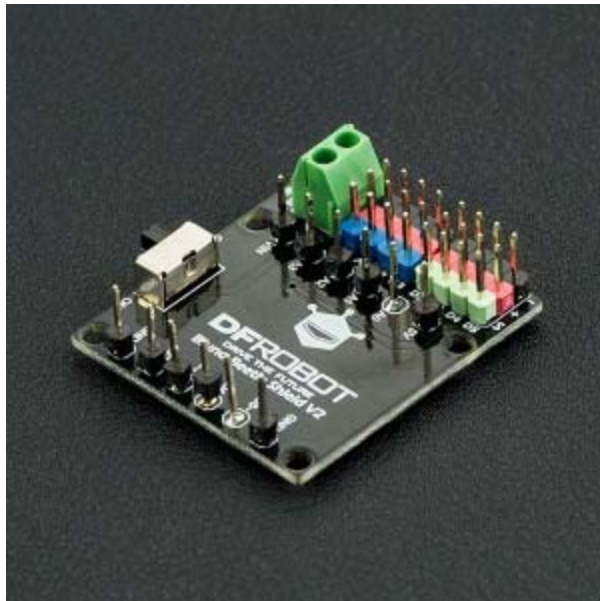

Bluno Beetle Shield SKU: DFR0356



Contents

- [1 Introduction](#)
- [2 Features](#)
- [3 Pinouts](#)
- [4 Caution](#)
- [5 FAQ](#)

Introduction

The Bluno Beetle Shield expands the Beetle's single pin I/Os analog and digital I/O pins to the 3 pin "gravity" interface, giving more power and ground connections and making it easier to attach "gravity" interface modules. It also includes a convenient external power supply and 5-8v switch to power the board on and off. To use the shield, the Bluno Beetle is stacked on to the shield's I/O pins and soldered in place.

Features

- 4 digital I/O pins: D2-D5
- 4 analog Input pin: A0-A3
- Vin input range: 5-8v
- A power switch
- Dimensions: 38 x 37 mm/ 1.5 x 1.45 inches
- Mounting holes x4 (3mm diameter)

Pinouts

Black: Ground (GND)
Red: Power (5V)
Blue: Analog Signal (A0-A3)

Black: Ground (GND)
Red: Power (VIN)
Green: Digital Signal (D2-D5)

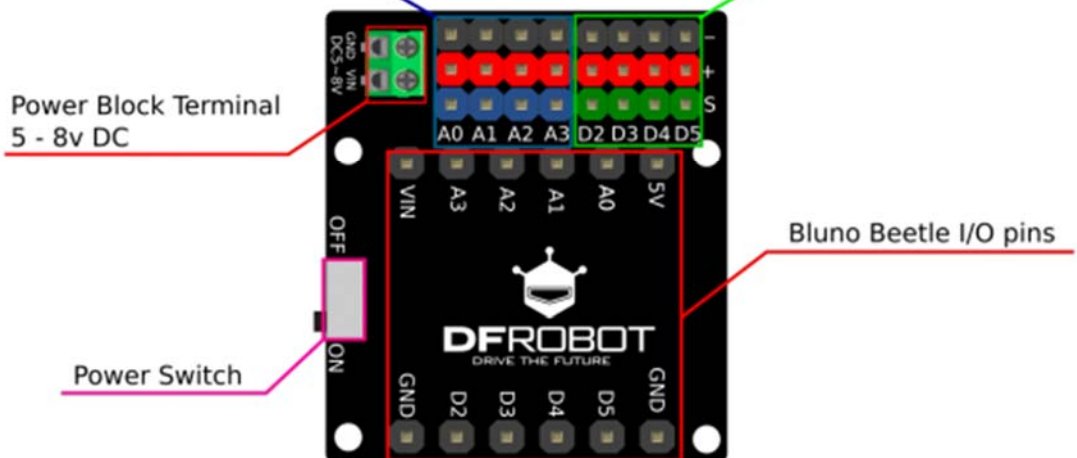

Note :

- The red VCC pins beside the Digital pins (D2~D5) are connecting to Vin port. If you connect the power over than 5.5, please don't connect 5V sensors and modules directly. Or they will be damaged.
- The red VCC pins beside the Analog pins (A0~A3) are connecting to Bluno 5V port directly.
- External power switch

Caution

- 1. If you plan to use the serial port or I2C interface you will need to solder leads to the solder pads on the back of the Beetle, as pictured:

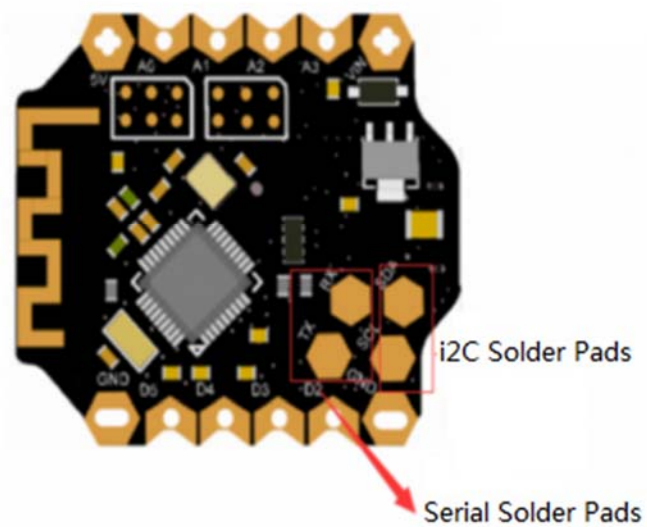

- 2. When soldering the Beetle to the Shield, make sure the orientation of the Beetle is correct so as to avoid connecting the wrong pins. The beetle should sit on the shield as pictured:

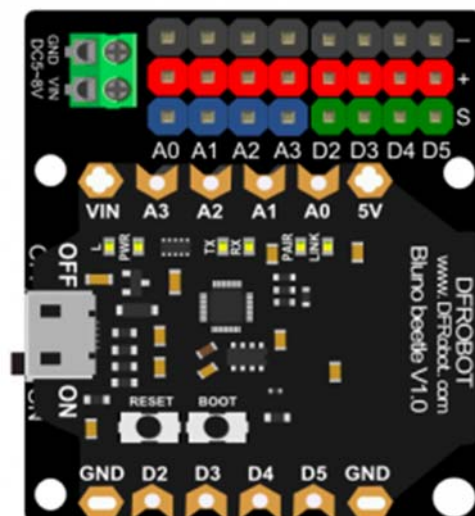

- 3. Please note that the Vcc pins for analog expansion pins is fixed at 5v. The Vcc pins for digital expansion pins is dependent on your power supply (5-8v DC)

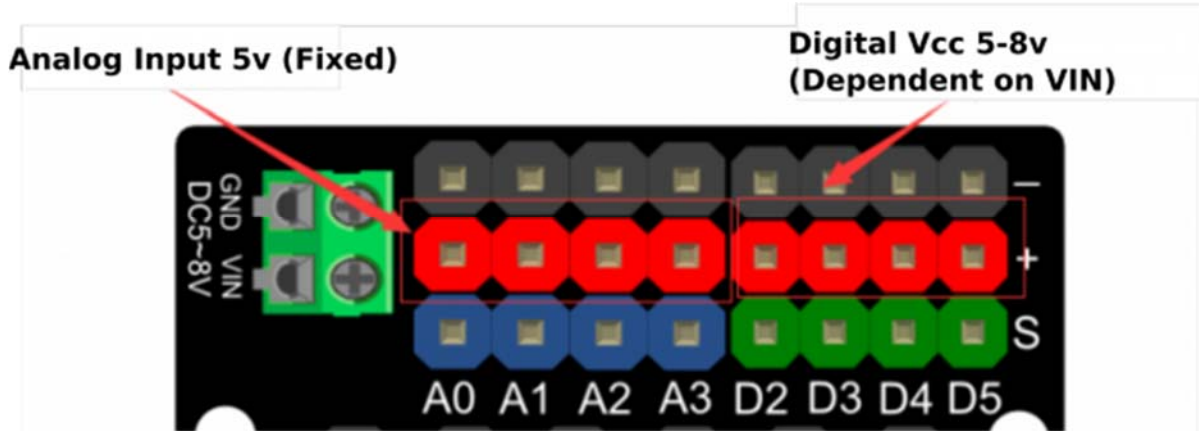

FAQ

There are no questions about this product yet. If you have any problems or suggestions, you are welcome to email us or post on the DFRobot forum!

For any questions/advice/cool ideas to share, please visit the [DFRobot Forum](#).