



## Bluno Nano - An Arduino Nano with Bluetooth 4.0

SKU:DFR0296



### INTRODUCTION

Here comes the second member in DFRobot Bluno family, the Bluno Nano. Came in a size of a gum, the Bluno Nano is perfect for BLE projects with limited space or weight.

Everything is getting smart now: wristbands and watches monitor your daily behaviours and become social; phone-controlled camera add-ons move and take shots as you like; smart gardens grow virtually in your ipad and sharing is made easy... The Bluetooth Low Energy technology

has made it easy and achievable. It is exciting to see more and more smart gadgets popping out, but, isn't building own smart device and solving your own problems even cooler?

DFRobot's Bluno family is first of its kind in intergrating BT 4.0(BLE) module into Arduino Uno, making it an ideal prototyping platform for developers to go wireless. You will be able to develop your own smart bracelet , smart pedometer and more. Through the low- power Bluetooth 4.0 technology, real-time low energy communication can be made really easy.

Bluno Nano also integrates a TI CC2540 BT 4.0 chip with the Arduino UNO development board. It allows wireless programming via BLE, supports Bluetooth HID, supports AT command to config the BLE, and you can upgrade BLE firmware easily. Bluno is also compatible with all Arduino Uno pins which means any project made with Uno can directly go wireless! Whatsmore, we also developed the App for the Bluno (both Android and IOS), and they are completely opensource, so that you can modify and develop your own hardware-software platform.

**Note: For expanding I/O ports, the Bluno Nano is compatible with all Arduino-Nano-compatible expansion shields. If you want to use Bluno Nano via other expansion shields, some extra wirings will be needed.**

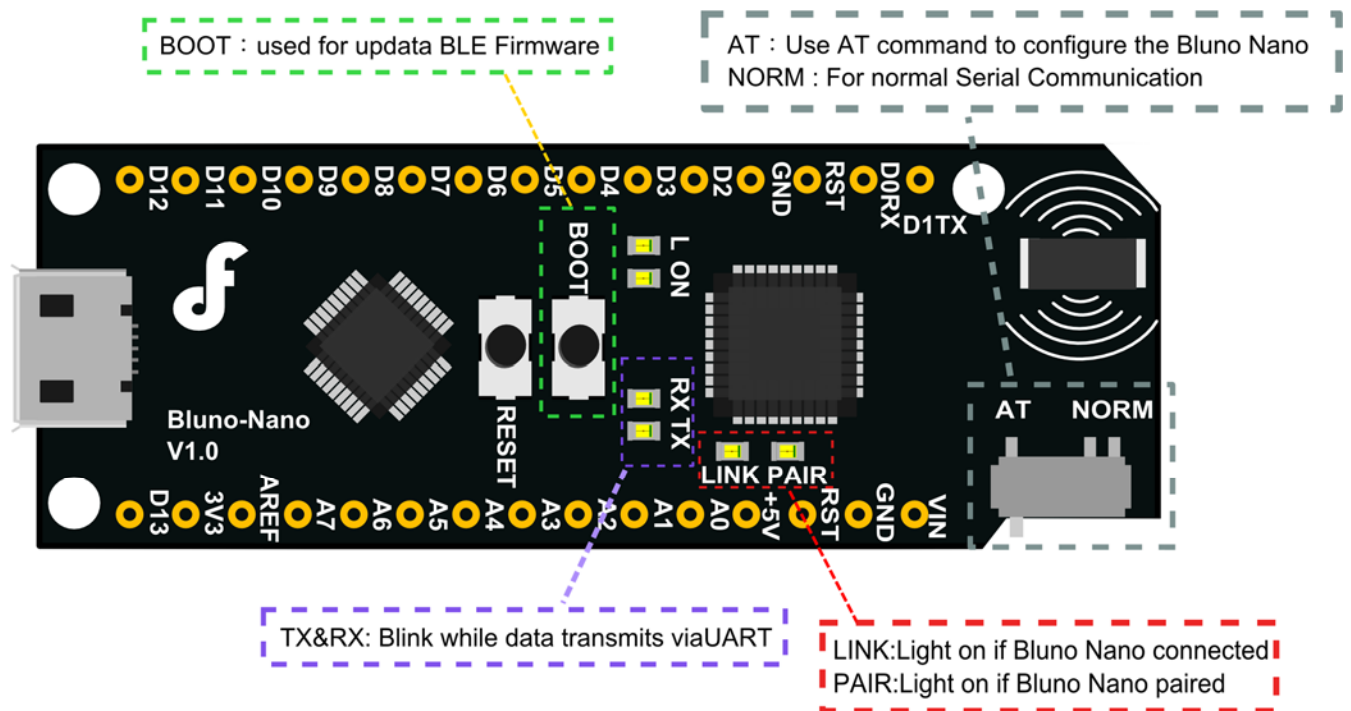

#### Version patch

- v1.3 - Improve the design of antenna to support up to 50m BLE communication by two Bluno nano

## **SPECIFICATION**

- On-board BLE chip: TI CC2540
- Wireless Programming Via BLE
- Support Bluetooth HID
- Support AT command to config the BLE
- Transparent communication through Serial
- Upgrade BLE firmware easily
- DC Supply:USB Powered or External 7V~12V DC
- Microcontroller: Atmega328
- Bootloader: Arduino Uno
- Compatible with the Arduino Uno pin mapping
- Size: 53x19x12mm(2.09x0.75x0.47")
- Weight: 20g