

**PART NUMBER:** CMA-6542PF

**DESCRIPTION:** electret condenser microphone

**SPECIFICATIONS**

directivity	omnidirectional	
sensitivity (S)	-42 ±3 db	f = 1KHz, 1Pa 0dB = 1V/Pa
sensitivity reduction (ΔS-Vs)	-3 dB	f = 1KHz, 1Pa Vs = 4.5 ~ 1.5 V dc
operating voltage	4.5 V dc (standard), 10 V dc (max.)	
output impedance (Zout)	2.2 KΩ	f = 1KHz, 1Pa
operating frequency (f)	20 ~ 20,000 Hz	
current consumption (IDSS)	0.5 mA max.	Vs = 4.5 V dc RL = 2.2KΩ
signal to noise ratio (S/N)	60 dBA	f = 1KHz, 1Pa A-weighted
operating temperature	-20 ~ +70° C	
storage temperature	-20 ~ +70° C	
dimensions	ø9.7 x 6.5 mm	
weight	0.70 g max.	
material	Al	
terminal	pin type (hand soldering only)	
RoHS	yes	

note: We use the "Pascal (Pa)" indication of sensitivity as per the recommendation of I.E.C. (International Electrotechnical Commission). The sensitivity of "Pa" will increase 20dB compared to the "ubar" indication. Example: -60dB (0dB = 1V/ubar) = -40dB (1V/Pa)

**APPEARANCE DRAWING**

tolerances not shown: ±0.3mm

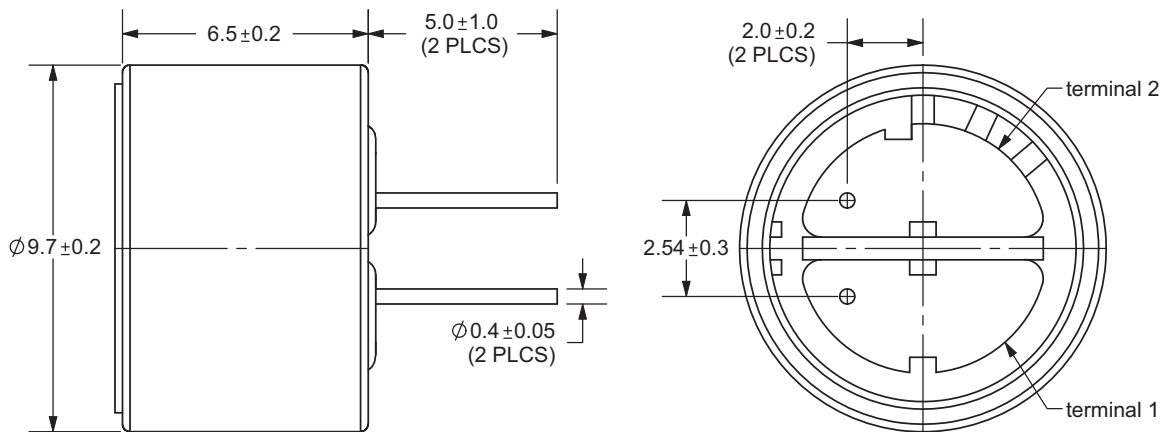

**PART NUMBER:** CMA-6542PF

**DESCRIPTION:** electret condenser microphone

**MEASUREMENT CIRCUIT**

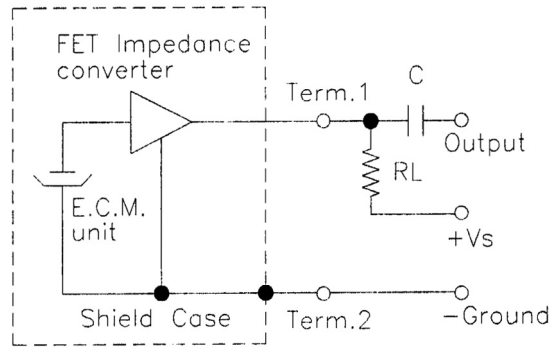

Schematic Diagram **RL=2.2KΩ**

**FREQUENCY RESPONSE CURVE**

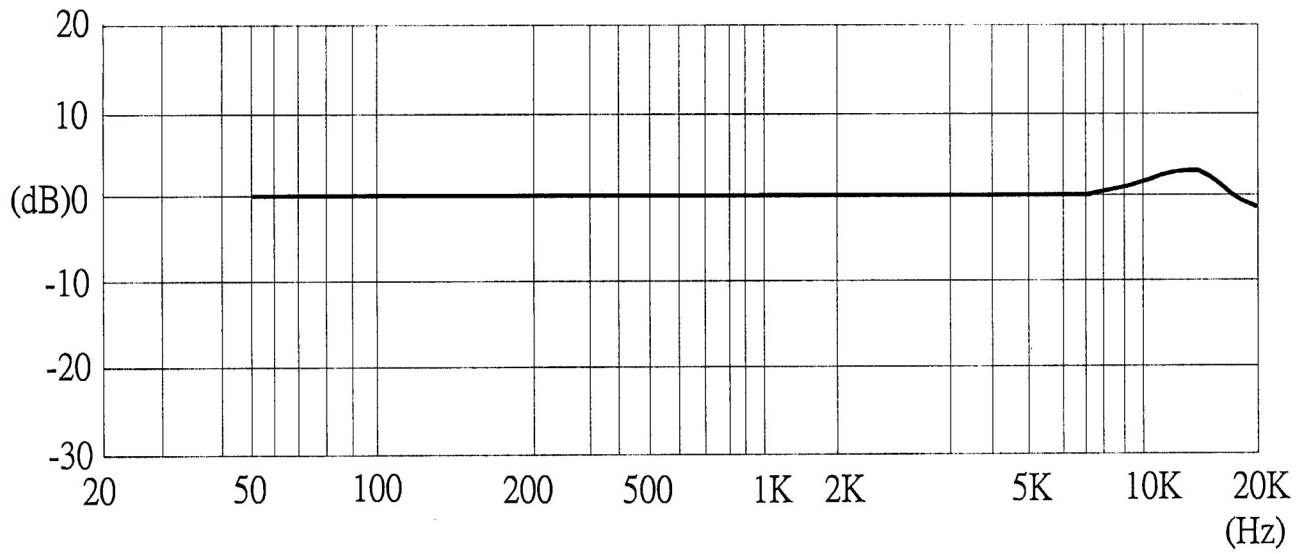

1.000V/PA

**PART NUMBER:** CMA-6542PF

**DESCRIPTION:** electret condenser microphone

**MECHANICAL CHARACTERISTICS**

item	test condition	evaluation standard
soldering heat resistance	Lead terminals are immersed in solder bath of 260 ±5°C for 2 ±0.5 seconds.	No interference in operation.
terminal mechanical strength	Apply to the terminal 0.5kg for 1 minute	No damage or cutting off.
vibration	The part will be measured after applying a vibration amplitude of 1.5 mm with 10 to 55 Hz band of vibration frequency to each of the 3 perpendicular directions for 2 hours.	After any tests, the sensitivity should be within ±3dB compared to the initial measurement.
drop test	The part will be dropped from a height of 1 m onto a 20 mm thick wooden board 3 times in 3 axes (X, Y, Z) for a total of 9 drops.	

**ENVIRONMENT TEST**

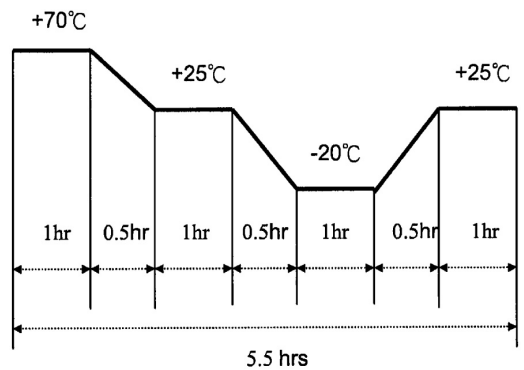
item	test condition	evaluation standard
high temp. test	After being placed in a chamber at +70°C for 72 hours.	The part will be measured after being placed at +25°C for 6 hours. After any tests, the sensitivity should be within ±3dB compared to the initial measurement.
low temp. test	After being placed in a chamber at -20°C for 72 hours.	
humidity test	After being placed in a chamber at +40°C and 90±5% relative humidity for 240 hours.	
temp. cycle test	The part shall be subjected to 10 cycles. One cycle will consist of: 	

**TEST CONDITIONS**

standard test condition	a) temperature: +5 ~ +35°C	b) humidity: 45 - 85%	c) pressure: 860-1060 mbar
judgement test condition	a) temperature: +25 ±2°C	b) humidity: 60 - 70%	c) pressure: 860-1060 mbar

**PART NUMBER:** CMA-6542PF

**DESCRIPTION:** electret condenser microphone

**PACKAGING**

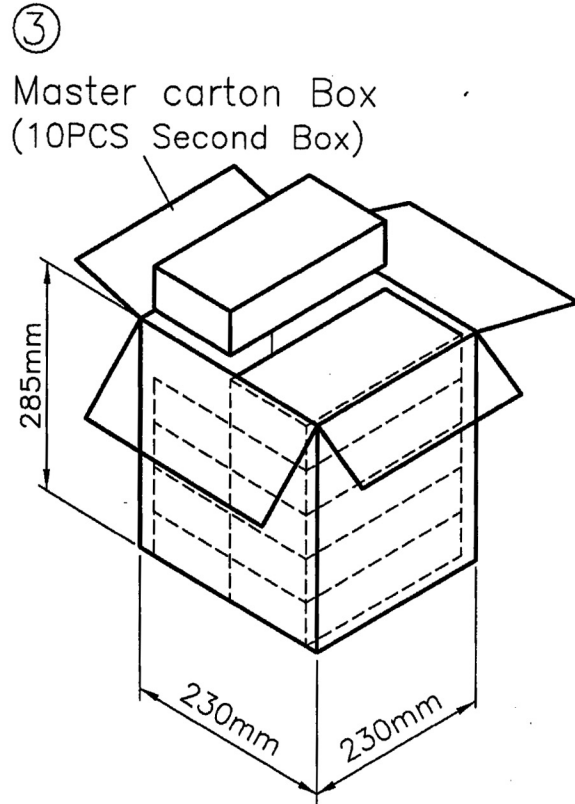
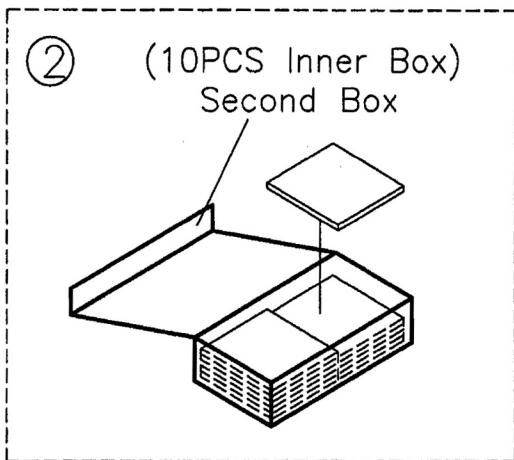
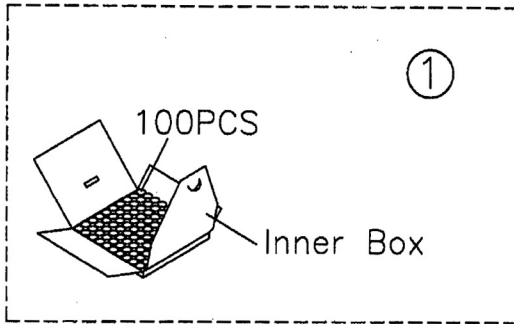

Inner Box		1x100PCS
Second Box	202mmx103mmx50mm	100PCSx10
Master carton Box	230mmx230mmx285mm	1000PCSx10