

METAL CASE, CASE-MOUNTED SEMICONDUCTORS

UP10 Series for TO-3 Dual Mount Applications

Natural Conv. (°C/W): 7.7

Forced Air (°C/W): 2

Mounting Envelope: 3.38" x 1.40" x .44"

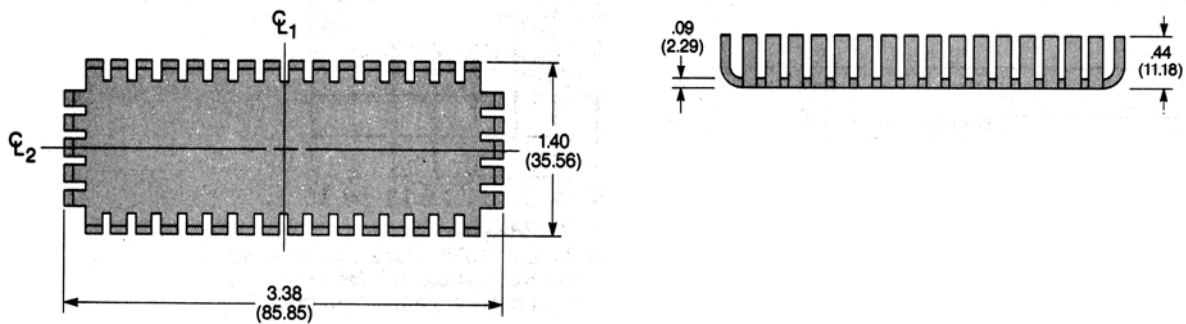

UP10-TO3-2CB w/(2) 2N3055 (TO-3) TRANSISTORS

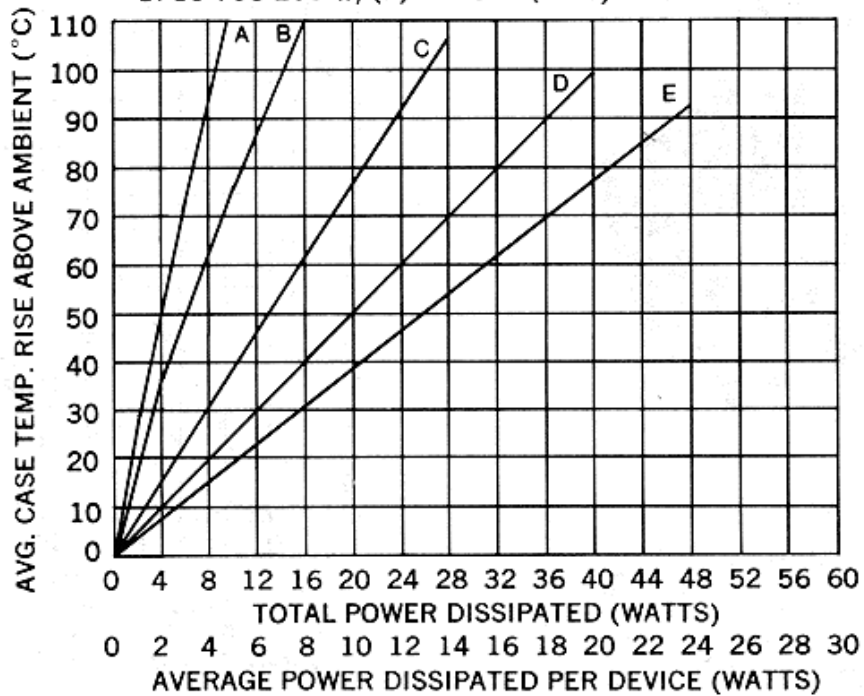

DESCRIPTION OF CURVES

- A. N.C. Horiz. Device Only Mounted to G-10.
- B. N.C Horiz. & Vert. With Dissipator.
- C. 200 FPM w/Diss.
- D. 500 FPM w/Diss.
- E. 1000 FPM w/Diss.

- Thermal Resistance Case to Sink is 0.1-0.3 °C/W w/Joint Compound.
- Derate 0.8 °C/watt per device for unplated part in natural convection only.

Ordering Information

CTS IERC PART NO.			Semiconductor Accommodated	Hole patt. ref. no.	Max. Weight (Grams)
Unplated	Comm'l. Black Anodize	Mil. Black Anodize			
UP10-TO3-2U	UP10-TO-3-2CB	UP10-TO3-2B	Two TO-3s	29	24.0
UP10-426-2U	UP10-426-2CB	UP10-426-2B	Universal	30	24.0
UP10-428-2U	UP10-428-2CB	UP10-428-2B	Two TO-3 (4-pin)	36	24.0

HOLE PATTERNS

29. Hole pattern no. 222 accommodates TO-3s. Available in UP10 series heat dissipators only.

30. Hole pattern no. 426 (Universal) accommodates two TO-3s, TO-66s, TO-126s, or TO-220s. Available in UP10 series heat dissipators only.

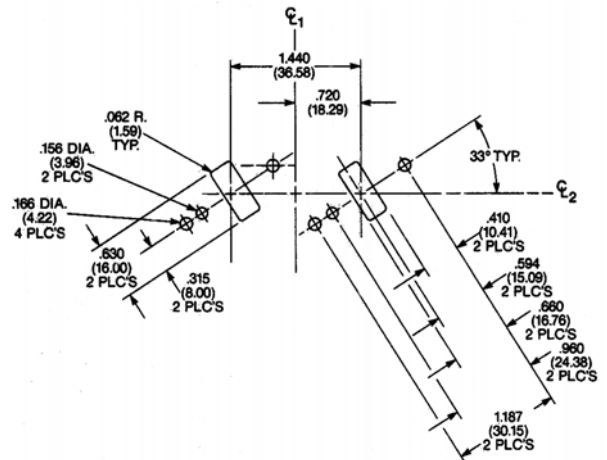
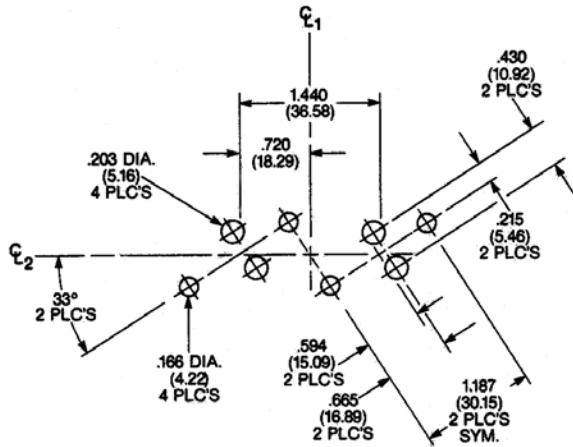

36. Hole pattern no. 428 accommodates two TO-3s (4-pin). Available in UP10 series heat dissipators only.

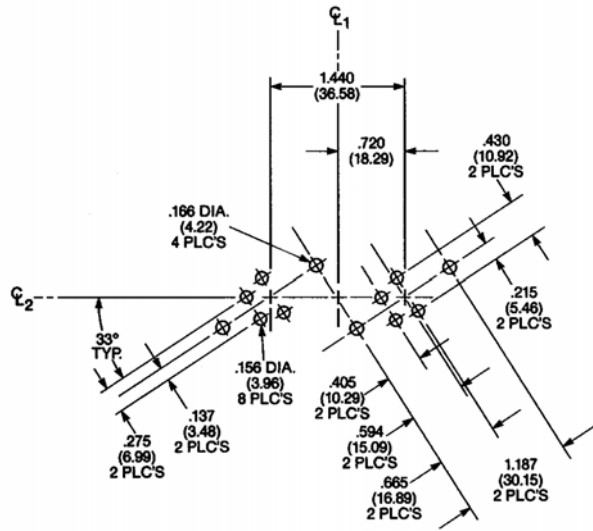

CTS IERC, Heat Sinks and Thermal Management Solutions

413 North Moss Street, Burbank, California 91502 Tel: (818) 842-7277 Fax: (818) 848-8872

Rev. 08-29-03