

## CPDVR105V0U-HF

RoHS Device  
Halogen Free

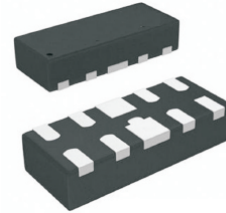

### Features

- IEC 61000-4-2 (ESD): Contact  $\pm 12\text{KV}$
- IEC61000-4-4 (FET): 40A-5/50ns
- Low clamping voltage
- Low capacitance: 0.8pF max.(Any I/O to GND.)

### Mechanical data

- Case: DFN2510-10 small outline plastic package
- Terminals: Matte tin plated, solderable per MIL-STD-750, method 2026.
- Mounting Compound Flammability Rating: UL 94V-0
- High temperature soldering guaranteed:  
260°C/10 second
- Weight: 0.015 grams(approx.).

### Circuit Diagram

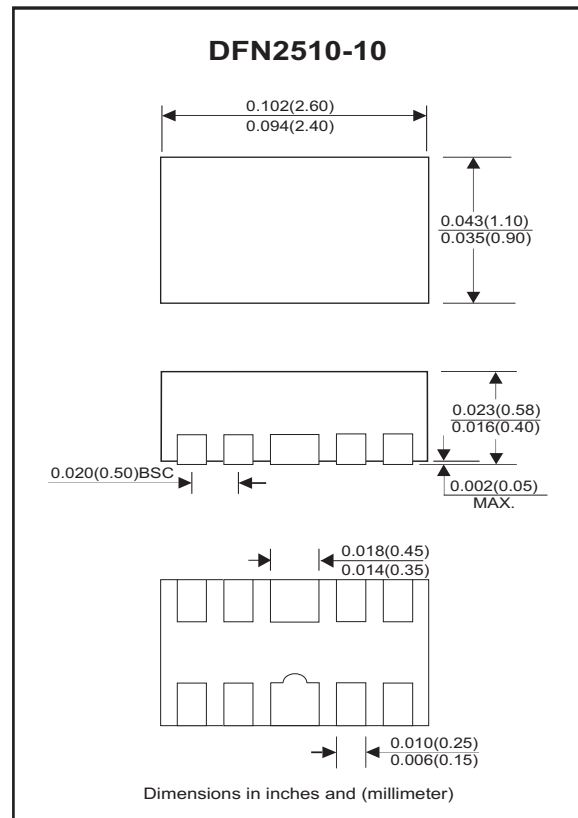
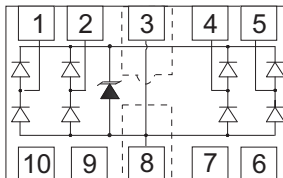

### Maximum Rating (at $T_A=25^\circ\text{C}$ unless otherwise noted)

Parameter	Conditions	Symbol	Value	Unit
Peak pulse power	$T_P = 8/20\mu\text{s}$	$P_{PP}$	100	W
Peak pulse current	$T_P = 8/20\mu\text{s}$	$I_{PP}$	5	A
ESD capability	IEC 61000-4-2(air) IEC 61000-4-2(contact)	ESD	$\pm 12$ $\pm 12$	kV
Operation temperature range		$T_j$	-55~+125	$^\circ\text{C}$
Storage temperature range		$T_{STG}$	-55~+150	$^\circ\text{C}$

### Electrical Characteristics (at $T_A=25^\circ\text{C}$ unless otherwise noted)

Parameter	Conditions	Symbol	Min	Typ	Max	Unit
Working peak reverse voltage	Any I/O Pin to GND	$V_{RWM}$			5.0	V
Breakdown voltage	$I_T = 1\text{mA}$ , Any I/O Pin to GND	$V_{BR}$	6.1		9.6	V
Reverse leakage current	$V_{RWM} = 5\text{V}$ , Any I/O Pin to GND	$I_R$			0.9	$\mu\text{A}$
Forward voltage	$I_F = 15\text{mA}$ , GND to any I/O Pin	$V_F$			1.15	V
Clamping voltage	$I_{PP} = 1\text{A}$ , $T_P = 8/20\mu\text{s}$ $I_{PP} = 5\text{A}$ , $T_P = 8/20\mu\text{s}$	$V_C$			12 20	V
Junction capacitance	$V_R = 0\text{V}$ , $f = 1\text{MHz}$ (I/O pin to I/O pin)	$C_J$			0.4	pF
	$V_R = 0\text{V}$ , $f = 1\text{MHz}$ (I/O pin to GND pin)	$C_J$			0.8	pF

## RATING AND CHARACTERISTIC CURVES (CPDVR105V0U-HF)

Fig.1 - 8/20us Peak Pulse Current  
Wave Form Acc. IEC 61000-4-5

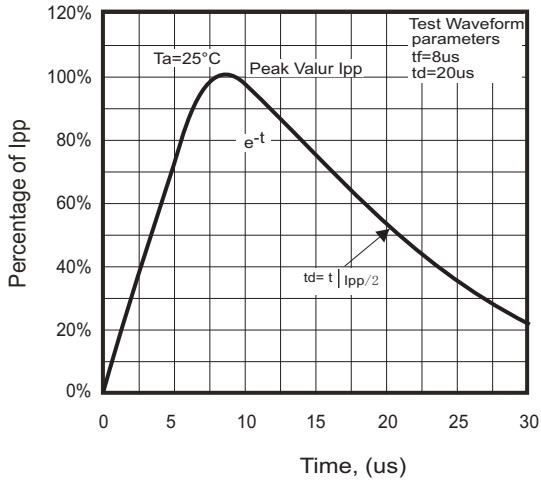

Fig.2 - Power Rating Derating Curve

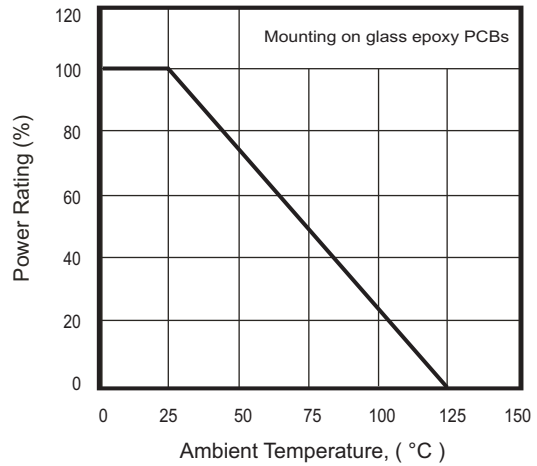

Fig.3 - Forward Characteristic

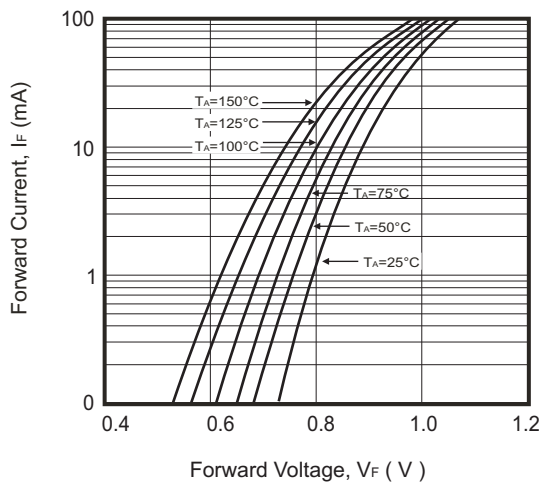

Fig.4 - Clamping Voltage Vs. Peak Pulse Current

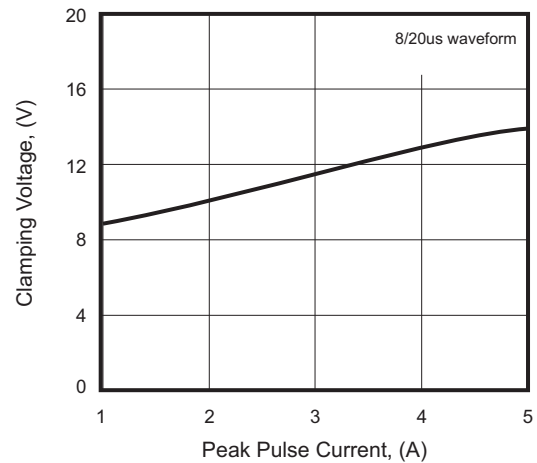
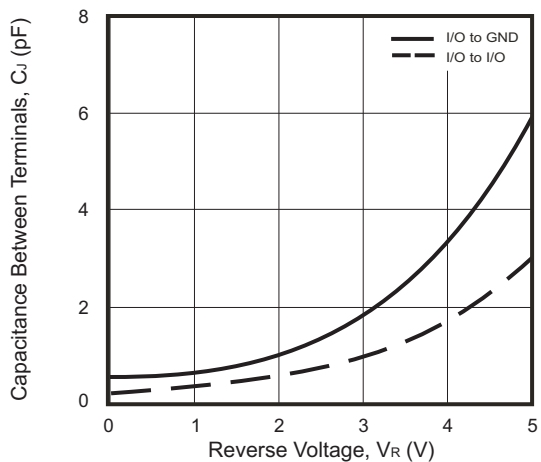
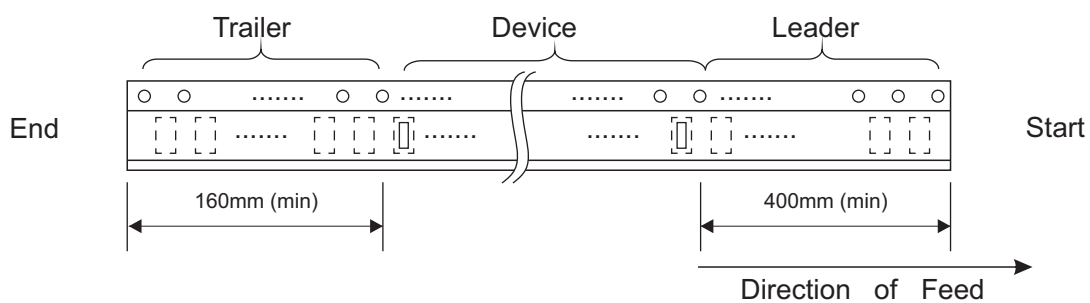
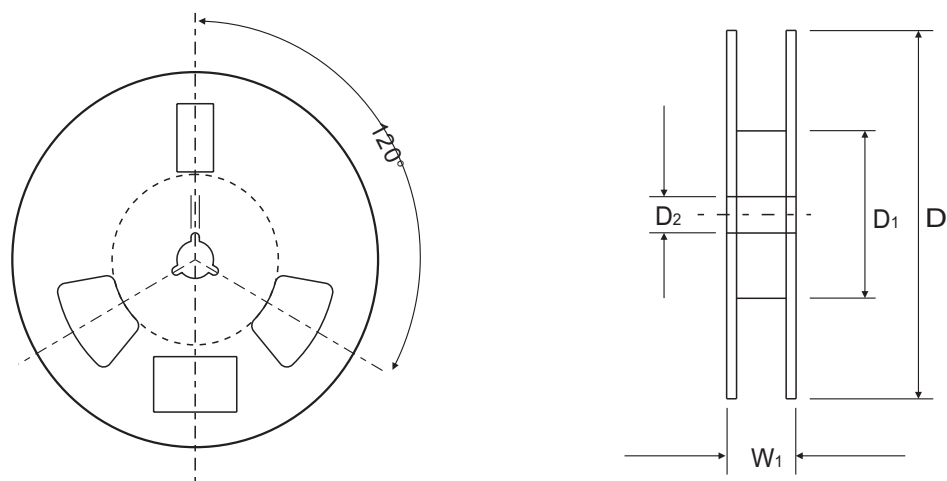
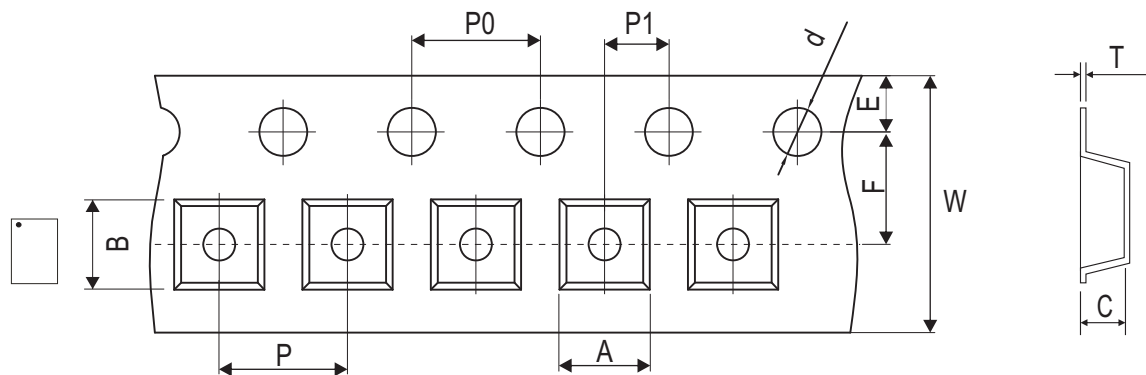

Fig.5 - Typical Capacitance Between Terminals Characteristics



## Reel Taping Specification



DFN2510-10	SYMBOL	A	B	C	d	D	D1	D2
	(mm)	1.20 ± 0.05	2.70 ± 0.05	0.70 ± 0.05	1.50 ± 0.10	180.00 +0.00 -3.00	60.00 ± 0.50	13.00 ± 0.20
	(inch)	0.047 ± 0.002	0.106 ± 0.002	0.028 ± 0.002	0.059 ± 0.004	7.087 +0.000 -0.118	2.362 ± 0.020	0.512 ± 0.008

DFN2510-10	SYMBOL	E	F	P	P0	P1	T	W	W1
	(mm)	1.75 ± 0.10	3.50 ± 0.05	4.00 ± 0.10	4.00 ± 0.10	2.00 ± 0.10	0.200 ± 0.03	8.00 ± 0.10	13.10 ± 1.30
	(inch)	0.069 ± 0.004	0.138 ± 0.002	0.157 ± 0.004	0.157 ± 0.004	0.079 ± 0.004	0.008 ± 0.002	0.315 ± 0.004	0.516 ± 0.051

## Marking Code

Part Number	Marking Code
CPDVR105V0U-HF	.0524X



## Suggested PAD Layout

SIZE	DFN2510-10	
	(mm)	(inch)
A	0.80	0.031
B	0.20	0.008
C	0.50	0.020
D	1.00	0.039
E	0.20	0.008
F	0.40	0.016
G	0.60	0.024
H	1.40	0.055

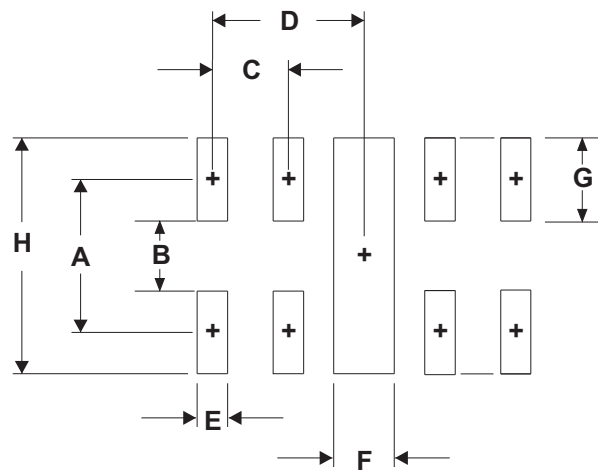

## Standard Packaging

Case Type	Qty Per Reel	Reel Size
	(Pcs)	(inch)
DFN2510-10	3,000	7