

Bottom Port Analogue Silicon Microphone

DESCRIPTION

The WM7133L is a low-profile silicon analogue microphone. It offers high Signal to Noise Ratio (SNR) and low power consumption and is suited to a wide variety of consumer applications.

The WM7133L incorporates Wolfson's proprietary CMOS/MEMS membrane technology, offering high reliability and high performance in a miniature, low-profile package. The WM7133L is designed to withstand the high temperatures associated with automated flow solder assembly processes. (Note that conventional microphones can be damaged by this process.)

FEATURES

- High SNR (64.5dB)
- Low variation in sensitivity (± 3 dB)
- Low current consumption (180 μ A)
- Analogue output
- Bottom Port LGA Package
- 1.5V to 3.7V supply

APPLICATIONS

- Mobile phone handsets
- Wearable devices
- Portable media players
- Digital cameras

BLOCK DIAGRAM

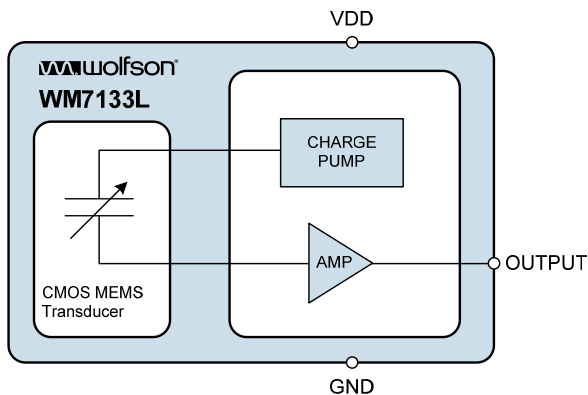

3D VIEW

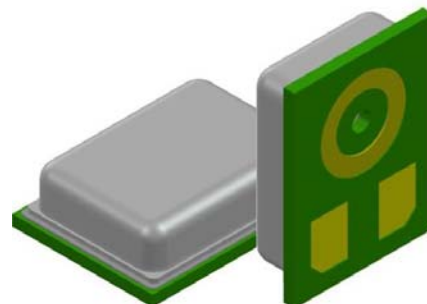

3.35mm x 2.50mm x 0.98mm LGA package

TABLE OF CONTENTS

DESCRIPTION	1
FEATURES	1
APPLICATIONS	1
BLOCK DIAGRAM	1
3D VIEW	1
TABLE OF CONTENTS	2
PIN CONFIGURATION	3
PIN DESCRIPTION	3
ORDERING INFORMATION	3
ABSOLUTE MAXIMUM RATINGS	4
IMPORTANT ASSEMBLY GUIDELINES	4
RECOMMENDED OPERATING CONDITIONS	4
ACOUSTIC AND ELECTRICAL CHARACTERISTICS	5
TERMINOLOGY	5
TYPICAL PERFORMANCE	6
APPLICATIONS INFORMATION	7
RECOMMENDED EXTERNAL COMPONENTS	7
OPTIMISED SYSTEM RF DESIGN	7
CONNECTION TO A WOLFSON AUDIO CODEC	8
PCB LAND PATTERN AND PASTE STENCIL	9
PACKAGE DIMENSIONS	10
IMPORTANT NOTICE	11
ADDRESS:	11
REVISION HISTORY	12

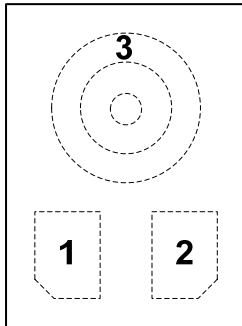
PIN CONFIGURATION

Top View

PIN DESCRIPTION

PIN	NAME	TYPE	DESCRIPTION
1	VDD	Supply	Analogue supply
2	OUTPUT	Analogue Output	Microphone analogue output signal
3	GND	Supply	Analogue ground

ORDERING INFORMATION

DEVICE	DESCRIPTION	TEMPERATURE RANGE	MOISTURE SENSITIVITY LEVEL	PEAK SOLDERING TEMPERATURE
WM7133LIMS/RV	Standard (tape and reel)	-40 to +100°C	MSL2A	+260°C

Note:

Reel quantity = 5000

All devices are Pb-free and Halogen free.

ABSOLUTE MAXIMUM RATINGS

Absolute Maximum Ratings are stress ratings only. Permanent damage to the device may be caused by continuously operating at or beyond these limits. Device functional operating limits and guaranteed performance specifications are given under Electrical Characteristics at the test conditions specified.



ESD Sensitive Device. This device is manufactured on a CMOS process. It is therefore generically susceptible to damage from excessive static voltages. Proper ESD precautions must be taken during handling and storage of this device.

Wolfson tests its package types according to IPC/JEDEC J-STD-020 for Moisture Sensitivity to determine acceptable storage conditions prior to surface mount assembly. These levels are:

MSL1 = unlimited floor life at <30°C / 85% Relative Humidity. Not normally stored in moisture barrier bag.

MSL2 = out of bag storage for 1 year at <30°C / 60% Relative Humidity. Supplied in moisture barrier bag.

MSL2A = out of bag storage for 4 weeks at <30°C / 60% Relative Humidity. Supplied in moisture barrier bag.

MSL3 = out of bag storage for 168 hours at <30°C / 60% Relative Humidity. Supplied in moisture barrier bag.

The Moisture Sensitivity Level for each package type is specified in Ordering Information.

CONDITION	MIN	MAX
Supply Voltage	-0.3V	+4.2V
Operating temperature range, T _A	-40°C	+100°C
Storage temperature prior to soldering	30°C max / 60% RH max	
Storage temperature after soldering	-40°C	+100°C

IMPORTANT ASSEMBLY GUIDELINES

Do not put a vacuum over the port hole of the microphone. Placing a vacuum over the port hole can damage the device.

Do not board wash the microphone after a re-flow process. Board washing and the associated cleaning agents can damage the device. Do not expose to ultrasonic cleaning methods.

Do not use a vapour phase re-flow process. The vapour can damage the device.

Please refer to application note WAN0273 (MEMS MIC Assembly and Handling Guidelines) for further assembly and handling guidelines.

RECOMMENDED OPERATING CONDITIONS

PARAMETER	SYMBOL	MIN	TYP	MAX	UNIT
Analogue Supply Range	VDD	1.5		3.7	V
Ground	GND		0		V

ACOUSTIC AND ELECTRICAL CHARACTERISTICS

Test Conditions: VDD=1.8V, 1kHz test signal, T_A = 25°C

PARAMETER	SYMBOL	TEST CONDITIONS	MIN	TYP	MAX	UNIT
Directivity			Omni-directional			
Polarity		Positive sound pressure	Positive output voltage			
Sensitivity	S	94dB SPL	-41	-38	-35	dBV
Acoustic Overload		No load, THD < 10%		126		dB SPL
Total Harmonic Distortion	THD	100dB SPL		0.1	1	%
		114dB SPL		0.2		
		122dB SPL		1		
Signal to Noise Ratio	SNR	A-weighted		64.5		dB
Dynamic Range	DR	A-weighted		92.5		dB
Frequency Response		-3dB low frequency		85		Hz
		+3dB high frequency		10600		
Acoustic Noise Floor		A-weighted		29.5		dB SPL
Electrical Noise Floor		A-weighted		-102.5		dBV
Power Supply Rejection Ratio	PSRR	217Hz sine wave, 100mV (peak-peak)		70		dB
Power Supply Rejection	PSR	217Hz square wave, 100mV (peak-peak)		-96		dBV
Current Consumption	I _{VDD}			180	240	μA
Output DC Impedance	Z _{OUT}			55		Ω

TERMINOLOGY

1. Sensitivity (dBV) - Sensitivity is a measure of the microphone output response to the acoustic pressure of a 1kHz 94dB SPL (1Pa RMS) sine wave.
2. Total Harmonic Distortion (%) – THD is the ratio of the RMS sum of the harmonic distortion products in the specified bandwidth (see note below) relative to the amplitude of the fundamental (ie. test frequency) output.
3. Signal-to-Noise Ratio (dB) – SNR is a measure of the difference in level between the output response of a 1kHz 94dB SPL sine wave and the idle noise output.
4. Dynamic Range (dB) – DR is the ratio of the 1% THD microphone output level (in response to a sine wave input) and the idle noise output level.
5. All performance measurements are carried out within a 20Hz to 20kHz bandwidth and, where noted, an A-weighted filter. Failure to use these filters will result in higher THD and lower SNR values than are found in the Acoustic and Electrical Characteristics. The low pass filter removes out of band noise.

TYPICAL PERFORMANCE

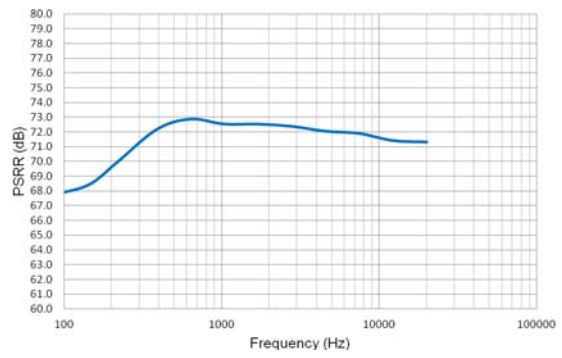
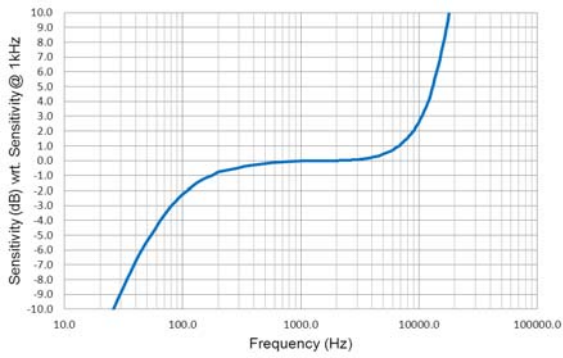

Sensitivity vs. Frequency

PSRR vs. Frequency

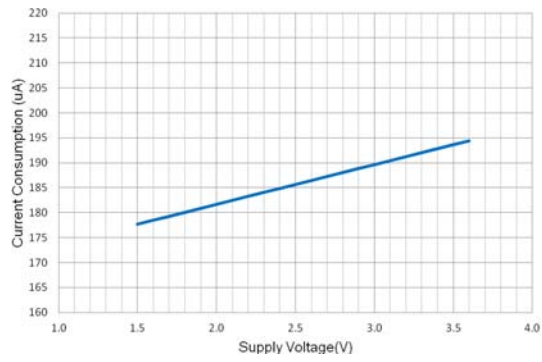
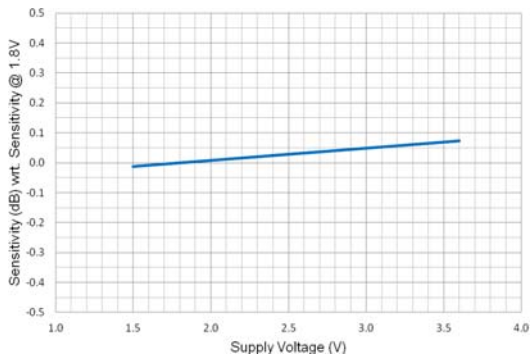

Sensitivity vs. Supply Voltage

Current Consumption vs. Supply Voltage

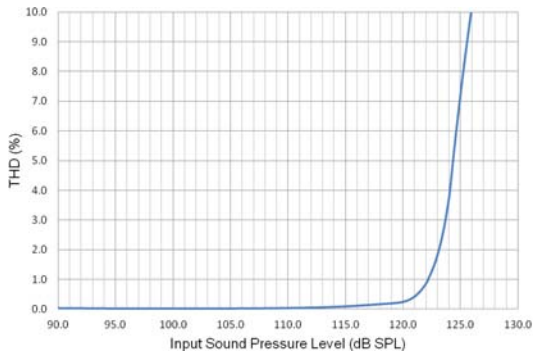

THD vs. Sound Pressure Level

APPLICATIONS INFORMATION

RECOMMENDED EXTERNAL COMPONENTS

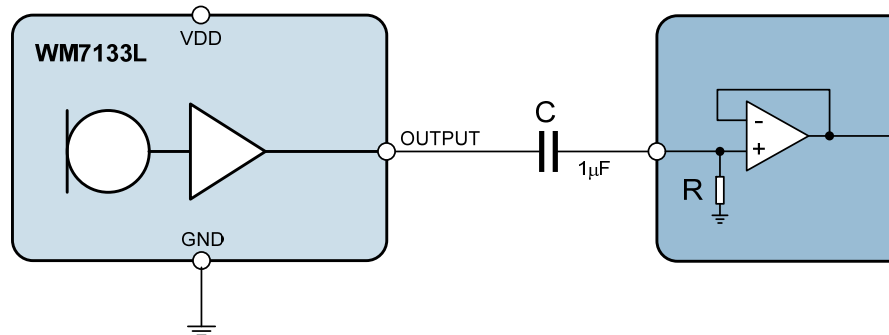

Figure 1 WM7133L Recommended External Components

A DC-blocking output capacitor is required on the OUTPUT pin, as illustrated in Figure 1. A single capacitor is required for a single-ended connection. The capacitor must be correctly selected as it affects the cut-off frequency of the output path. A low cut-off frequency is desirable as it means there is no significant filtering of the audio bandwidth.

The 3dB cut-off frequency of the output path is given by the equation below, where C is the output capacitance and R is the input resistance of the other circuit.

$$\text{3dB filter roll-off frequency} = \frac{1}{2\pi RC}$$

A typical recommended configuration, with 1µF DC-blocking capacitor and 20kΩ minimum input circuit impedance, gives a 3dB cut-off frequency of 10Hz or less. Tantalum electrolytic capacitors are particularly suitable for the DC-blocking components as they offer high stability in a small package size.

OPTIMISED SYSTEM RF DESIGN

For optimised RF design please refer to document WAN0278 (Recommended PCB Layout for Microphone RF Immunity in Mobile Cell Phone Applications) for further information.

CONNECTION TO A WOLFSON AUDIO CODEC

Wolfson provides a range of audio CODECs incorporating an analogue microphone input interface; these support connection to silicon microphones such as the WM7133L.

The recommended connection of a WM7133L silicon microphone is illustrated in Figure 2 (for single-ended mode) and Figure 3 (for pseudo-differential mode).

A DC blocking capacitor is required, as described in the previous section. A 2.2µF decoupling capacitor is also recommended; this should be positioned close to the VDD pin of the WM7133L.

Further information on Wolfson audio CODECs is provided in the respective product datasheet, which is available from the Wolfson website.

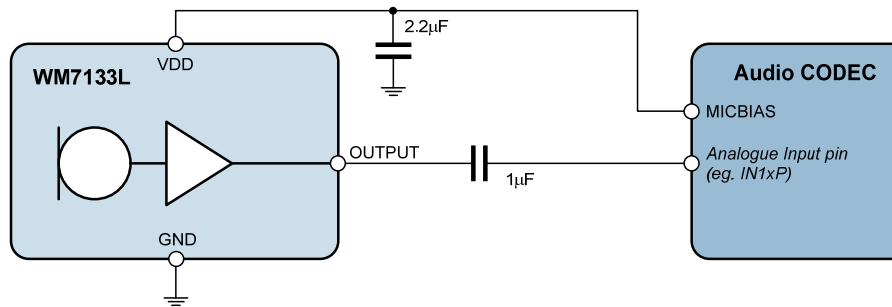

Figure 2 WM7133L Single-ended Connection

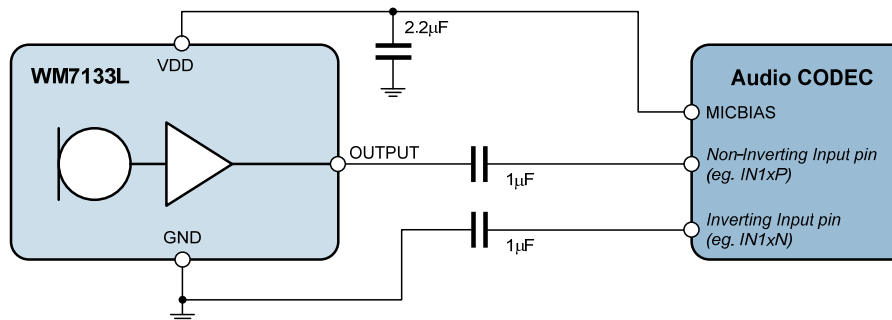

Figure 3 WM7133L Pseudo-differential Connection

PCB LAND PATTERN AND PASTE STENCIL

The recommended PCB Land Pattern and Paste Stencil Pattern for the WM7133L microphone are shown in Figure 4 and Figure 5.

See also Application Note WAN0284 (General Design Considerations for MEMS Microphones) for further details of PCB footprint design.

Full definition of the package dimensions is provided in the "Package Dimensions" section.

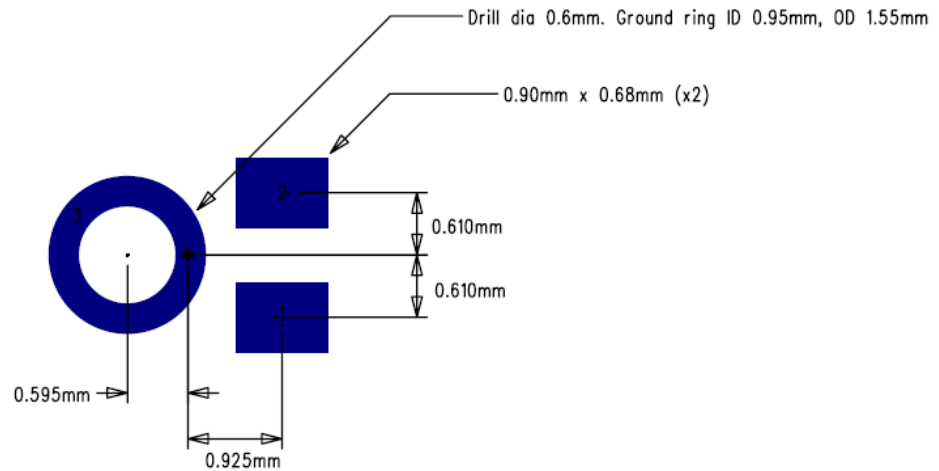

Figure 4 DM126 - PCB Land Pattern, Top View

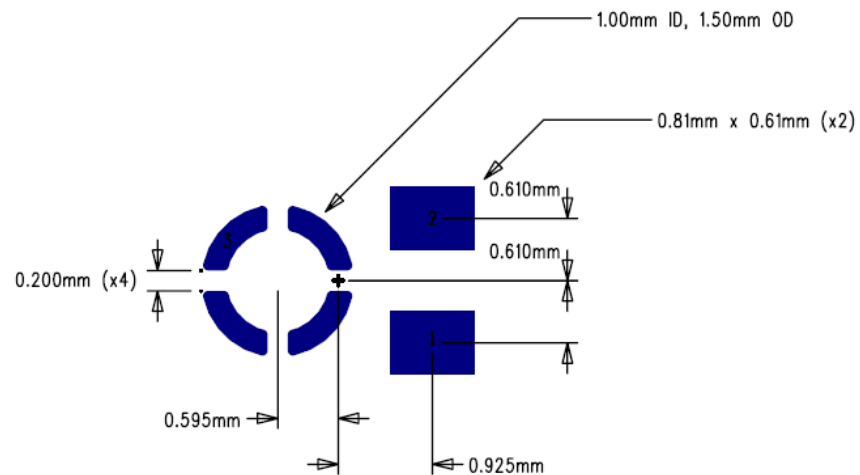
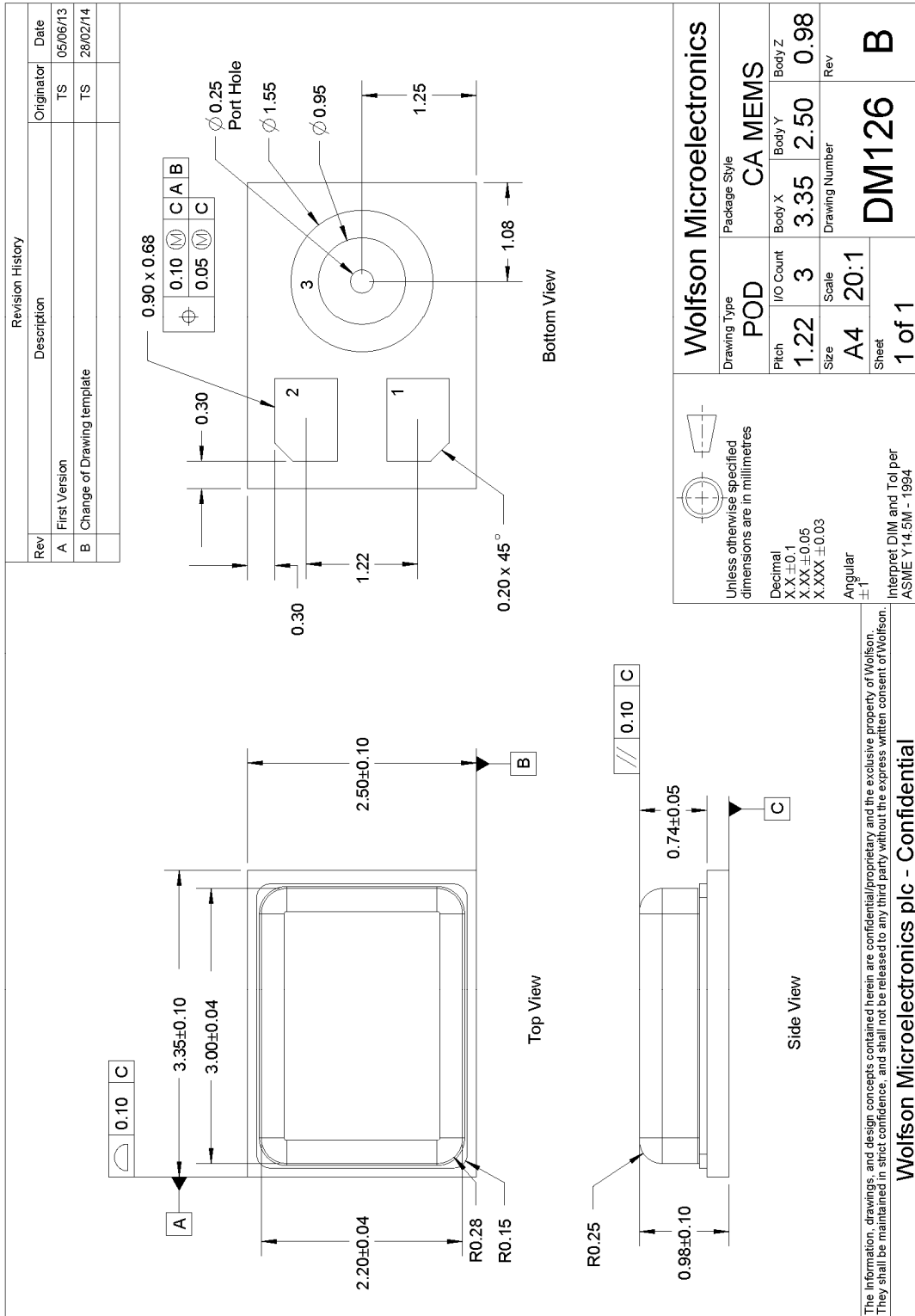

Figure 5 DM126 - Paste Stencil Pattern, Top View

PACKAGE DIMENSIONS



IMPORTANT NOTICE

Wolfson Microelectronics plc ("Wolfson") products and services are sold subject to Wolfson's terms and conditions of sale, delivery and payment supplied at the time of order acknowledgement.

Wolfson warrants performance of its products to the specifications in effect at the date of shipment. Wolfson reserves the right to make changes to its products and specifications or to discontinue any product or service without notice. Customers should therefore obtain the latest version of relevant information from Wolfson to verify that the information is current.

Testing and other quality control techniques are utilised to the extent Wolfson deems necessary to support its warranty. Specific testing of all parameters of each device is not necessarily performed unless required by law or regulation.

In order to minimise risks associated with customer applications, the customer must use adequate design and operating safeguards to minimise inherent or procedural hazards. Wolfson is not liable for applications assistance or customer product design. The customer is solely responsible for its selection and use of Wolfson products. Wolfson is not liable for such selection or use nor for use of any circuitry other than circuitry entirely embodied in a Wolfson product.

Wolfson's products are not intended for use in life support systems, appliances, nuclear systems or systems where malfunction can reasonably be expected to result in personal injury, death or severe property or environmental damage. Any use of products by the customer for such purposes is at the customer's own risk.

Wolfson does not grant any licence (express or implied) under any patent right, copyright, mask work right or other intellectual property right of Wolfson covering or relating to any combination, machine, or process in which its products or services might be or are used. Any provision or publication of any third party's products or services does not constitute Wolfson's approval, licence, warranty or endorsement thereof. Any third party trade marks contained in this document belong to the respective third party owner.

Reproduction of information from Wolfson datasheets is permissible only if reproduction is without alteration and is accompanied by all associated copyright, proprietary and other notices (including this notice) and conditions. Wolfson is not liable for any unauthorised alteration of such information or for any reliance placed thereon.

Any representations made, warranties given, and/or liabilities accepted by any person which differ from those contained in this datasheet or in Wolfson's standard terms and conditions of sale, delivery and payment are made, given and/or accepted at that person's own risk. Wolfson is not liable for any such representations, warranties or liabilities or for any reliance placed thereon by any person.

ADDRESS:

Wolfson Microelectronics plc
Westfield House
26 Westfield Road
Edinburgh
EH11 2QB

Tel :: +44 (0)131 272 7000

Fax :: +44 (0)131 272 7001

Email :: sales@wolfsonmicro.com

REVISION HISTORY

DATE	REV	DESCRIPTION OF CHANGES	PAGE	CHANGED BY
02/10/13	1.0	First Release		KC
06/12/13	1.1	CODEC referenced changed to WM8280.		JMacD
18/12/13	1.1	Acoustic and Electrical Characteristics: Polarity added Updates to: SNR Dynamic Range Acoustic Noise Floor Electrical Noise Floor PSRR		MR
19/12/13	2.0	Product Status updated to Preliminary Technical Data		JMacD
29/01/14	3.0	Product Status updated to Pre-Production		JMacD
26/02/14	3.0	Formatting changes, incorporating 3D image on front page. Updates to Electrical Characteristics and Typical Performance graphs. PCB Land Pattern updated; Paste Stencil drawing added. New Package Drawing incorporated.	1 5,6 9 10	PH
28/02/14	3.0	Removed reference to WM8280	8	CT
24/04/14	3.1	Miscellaneous formatting updates Recommended external components updated	1, 5 8	PH

Mouser Electronics

Authorized Distributor

Click to View Pricing, Inventory, Delivery & Lifecycle Information:

[Wolfson Microelectronics:](#)

[WM7133L-1701-MS3-M](#)