

## Evaluation Board for the CS44L11

### Features

- 23 mW/Channel into 16  $\Omega$  at 2.4 V
- Variable power supplies from 1.8 V to 2.4 V
- Digital bass boost and treble boost
- Programmable digital volume control
- Short circuit protection
- >90% amplifier efficiency

### Description

The CDB44L11 is an excellent means to quickly demonstrate the CS44L11 Cirrus Digital Power Headphone Amplifier IC. Analysis requires only a digital signal source and an analog signal analyzer.

As shown below, the CS44L11 takes PCM digital audio input and converts it to a PWM output. This 16-pin TSSOP IC provides volume up/down, treble boost, bass boost and mute functions via push buttons and a micro controller using an I<sup>2</sup>C interface. A RS232 interface is provided for programming the micro controller.

The CS8420 is a receiver and sample rate converter. It takes in the S/PDIF at a range of input sample rates and generates a PCM output signal at a fixed sample rate.

The low pass filter removes high frequency components from the output PWM signal effectively converting it from digital to analog.

### ORDERING INFORMATION

CDB44L11

Demonstration Board

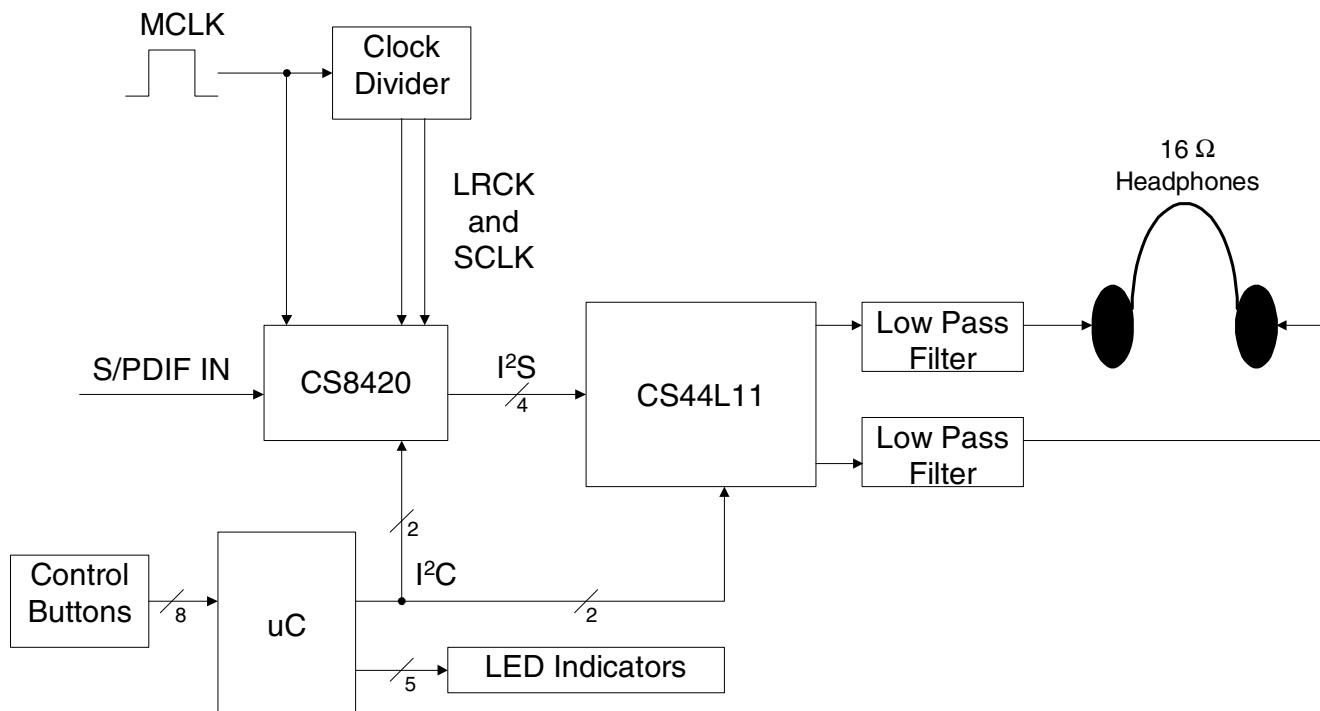

## TABLE OF CONTENTS

<b>1. CDB44L11 SYSTEM OVERVIEW .....</b>	<b>3</b>
<b>2. SCHEMATIC DESCRIPTIONS .....</b>	<b>3</b>
2.1 CS44L11 Headphone Monitor and Output Filter .....	3
2.2 Clocking .....	4
2.3 CS8420 Sample Rate Converter .....	4
2.4 Microcontroller .....	4
2.5 Power Supplies and Level-Shifting .....	4
<b>3. OPERATION INFORMATION .....</b>	<b>6</b>
3.1 Operating Instructions .....	6
<b>4. CONTROL FUNCTIONS .....</b>	<b>7</b>
4.1 Control Buttons .....	7
4.2 LED Status .....	7
4.3 CS44L11 Initialization .....	9
<b>5. BILL OF MATERIALS .....</b>	<b>17</b>
<b>6. REVISION HISTORY .....</b>	<b>20</b>

## LIST OF FIGURES

Figure 1. CS44L11 PWM Headphone Amplifier.....	10
Figure 2. CS8420 S/PDIF Receiver and Sample Rate Converter.....	11
Figure 3. Microcontroller.....	12
Figure 4. Power Supply .....	13
Figure 5. Assembly Drawing .....	14
Figure 6. Top Layer .....	15
Figure 7. Bottom Layer.....	16

## LIST OF TABLES

Table 1. Volume Status LED Decodes.....	8
Table 2. Treble/Bass Boost Status LED Decodes.....	8
Table 3. Initial CS44L11 Register Settings.....	9
Table 4. Revision History .....	20

## 1. CDB44L11 SYSTEM OVERVIEW

The CDB44L11 is an excellent means of quickly demonstrating the CS44L11. The CS8420 digital audio interface receiver provides an interface to digital audio sources including the majority of digital audio test equipment.

## 2. SCHEMATIC DESCRIPTIONS

### 2.1 CS44L11 Headphone Monitor and Output Filter

The CS44L11, shown in Figure 1, can accept sampling frequencies varying from 8 kHz to 96 kHz and can produce a PWM frequency ranging from 8 X Fs to 48 X Fs (refer to CS44L11 datasheet). In this design the 8 X Fs mode is used with a 48.25 kHz sample frequency (Fs), which will result in a 386 kHz PWM switching frequency.

As shown in Figure 1, L3, L4, C29, and C30 form the 2nd order low pass LC filter for the output audio. The following equations show how to calculate the filter values:

$$C_{\text{filter}} = 0.707 / (6.283 * f_c * R_L)$$

$$L_{\text{filter}} = (1.414 * R_L) / (6.283 * f_c)$$

where:

$f_c$  = desired -3 dB frequency of the filter

$R_L$  = the nominal speaker load impedance

If you choose  $f_c = 35$  kHz,  $R_L = 16$  W, then:

$$C_{\text{filter}} = 0.707 / (6.283 * 35000 * 16) = 0.2009 \mu\text{F}$$

$$L_{\text{filter}} = (1.414 * 16) / (6.283 * 35000) = 102.881 \mu\text{H}$$

Choosing practical component values:

$$C_{\text{filter}} = 0.22 \mu\text{F}$$

$$L_{\text{filter}} = 100 \mu\text{H}$$

Output distortion is directly related to the inductor quality. The inductors should have a saturation current of at least 150 mA for  $R_L = 16 \Omega$ . This design uses the Central Technologies CTGSR74B 100  $\mu\text{H}$  inductors for the output filter. 220  $\mu\text{F}$  capacitors are used to block any DC signal from being heard at the output. For maximum output power, low ESR capacitors should be used on the output.

## 2.2 Clocking

The provided MCLK oscillator frequency is 12.352 MHz. Any oscillator between 6.4 MHz and 24.576 MHz may be used in the socket. The MCLK signal is divided by the clock divider to produce SCLK (MCKL/4), and LRCK (MCKL/256). Using a 12.352 MHz MCLK, SCLK is 3.088 MHz, and LRCK is 48.25 kHz.

## 2.3 CS8420 Sample Rate Converter

Refer to Figure 2. The CS8420 is a S/PDIF receiver and sample rate converter. It is configured to accept data at any sample rate between 32 kHz and 96 kHz and transmits data in PCM audio data format based on the MCLK oscillator frequency. The CS8420, while not required, improves system performance by reducing clock jitter and providing one fixed output frequency. In this design, the 48.25 kHz sample rate was chosen so that the CS8420 does not perform 1:1 conversion when receiving 48 kHz input data. Noise can be introduced into the system when a 1:1 conversion is performed and should be avoided for optimal performance. For more information please refer to the CS8420 datasheet.

## 2.4 Microcontroller

Figure 3 shows the host microcontroller circuitry. There are 8 buttons for control features, 5 LEDs to indicate status, and an I<sup>2</sup>C interface to the CS8420 and the CS44L11. See Table 3 for the initial CS44L11 register settings. After power is first applied to the board or the reset button is pressed, all settings will revert to the default settings.

The board is populated with a Motorola MC68HC908GP32 with the software preprogrammed to run the CDB44L11. The microcontroller code was written in C and compiled with the 'COSMIC C Compiler'.

The microcontroller uses the I<sup>2</sup>C control bus to read and write to the CS44L11 control registers - refer to CS44L11 data sheet for more information.

## 2.5 Power Supplies and Level-Shifting

Figure 4 shows the power supply and level shifting circuitry. Due to the CS44L11 operating at below +5.0 V, level-shifting circuitry has been included to allow for operation with the microcontroller and the CS8420, both of which must run at +5.0 V.

The CS44L11 uses a half bridge output stage and is therefore affected by power supply pumping. Power supply pumping is a phenomenon observed in half-bridge switching amplifiers. It is caused by stored energy in the output inductor that is fed back into the power supply during switching. To compensate for power supply pumping, a resistive load is used to dissipate the

switching current. In most designs this may be omitted due to other system components loading the supply line and dissipating the current. The resistive load is only used to simulate a circuit load.

In the CS44L11, the output MOSFETs directly switch between ground and VA\_HP, therefore the performance of the audio output from the amplifier is adversely affected any disturbance on the power rails. To get the best performance power supply characteristics and power supply de-coupling are critical.

Dynamic Range will be affected by switching noise. To reduce switching noise large value power supply bypass capacitors must be used. This circuit uses a 0.1  $\mu\text{F}$  and 1.0  $\mu\text{F}$  ceramic capacitor as well as a 100  $\mu\text{F}$  low ESR tantalum capacitor between the VA\_HP supply rail and ground. Optimally these should be placed as close to the CS44L11 pins 12 and 13 as possible. If a DC-DC converter is used in the system its switching frequency should be locked to the CS44L11 PWM switching frequency to reduce switching noise.

Power supply source impedance has a direct affect on the output distortion. A DC-DC converter is a very low impedance source and will offer the best THD+N performance. Using a linear power supply offers the next lowest impedance, while running directly from batteries to the VA\_HP pins offers the highest impedance and therefore the highest distortion.

A 47  $\mu\text{H}$  inductor (L1) is used on the digital power supply of the CS44L11 to suppress noise. This may be omitted if system noise is not an issue in your design.

### 3. OPERATION INFORMATION

#### 3.1 Operating Instructions

- 1) Connect an optical or coaxial S/PDIF signal to the S/PDIF input (OPT1 or J5).
- 2) Connect the output to either headphones or an analog analyzer. If using the RCA test jacks (J8 and J9) a 16  $\Omega$  dummy load is provided in circuit. If using the headphone jack (J3) please use a 16  $\Omega$  dummy load or 16  $\Omega$  headphones.
- 3) Verify that all power supplies are turned off and:
  - a. Connect +5.0 V to the terminal marked +5 V (J4).
  - b. Connect from +1.8 V to +2.4 V to the terminal marked VD\_HP (J6).
  - c. Connect from +1.8 V to +2.4 V to the terminal marked VA\_IN (J7).
  - d. Connect the power supply common ground to the terminal marked GND.
  - e. Verify that all power supply output voltages are set correctly to correspond to the setting on the CDB44L11 and apply power to the board.
- 4) Once power is applied the volume LEDs will illuminate. Adjust settings as required with buttons - note that the volume, bass, and treble buttons do not 'ramp' and must be pushed for each increment/decrement. The volume level will initialize at -24 dB.

## 4. CONTROL FUNCTIONS

### 4.1 Control Buttons

The function of the Control Buttons (Tables 1 and 2) is as follows:

- **Volume Up** - Adds 1 dB to current volume setting.
- **Volume Dn** - Subtracts 1 dB from current volume setting.
- **Treble Up** - Adds 1 dB to current treble setting.
- **Treble Dn** - Subtracts 1 dB from current treble setting.
- **Bass Up** - Adds 1 dB to current bass setting.
- **Bass Dn** - Subtracts 1 dB from current bass setting.
- **Mute** - Mutes audio and sets PWM to modulated 50% duty cycle.
- **Reset** - Upon release of the RESET Button, the microcontroller loads the default settings from the flash memory into RAM. The RST line is pulled HI and these default settings are written to the CS44L11 and the CS8420.

### 4.2 LED Status

The CDB44L11 has 5 LEDs (D20 - D24) to indicate volume, tone and mute settings and 1 fault LED (D25). The LED readout will normally indicate the volume level per Table 1. When one of the Treble Up/Down or Bass Up/Down buttons is pressed, the LEDs will show the Treble Boost or Bass Boost setting as depicted in Table 2. When the button is released the LEDs will continue to show the Treble/Bass Boost setting for a period of 2 seconds and will then return to indicating the volume setting. In Table 1 and Table 2, a “1” indicates that the LED is lit up.

The MUTE button toggles operation between mute and un-mute. When the amplifier is muted the LEDs flash at a 0.5 Hz rate.

D25 (LED near the CS8420 Receiver) indicates when there is a loss of input signal or any other problem in the receiver.

Volume [dB]	LED Pattern				
	D20	D21	D22	D23	D24
+12	1	1	1	1	1
+11	1	1	1	1	0
+10	1	1	1	0	1
+9	1	1	1	0	0
+8	1	1	0	1	1
+7	1	1	0	1	0
+6	1	1	0	0	1
+5	1	1	0	0	0
+4	1	0	1	1	1
+3	1	0	1	1	0
+2	1	0	1	0	1
+1	1	0	1	0	0
0	1	0	0	1	1
-1	1	0	0	1	0
-2	1	0	0	0	1
-3	1	0	0	0	0
-4	0	1	1	1	1
-5	0	1	1	1	0
-6	0	1	1	0	1
-7	0	1	1	0	0
-8	0	1	0	1	1
-9	0	1	0	1	0
-10	0	1	0	0	1
-11	0	1	0	0	0
-15 to -12	0	0	1	1	1
-18 to -16	0	0	1	1	0
-21 to -19	0	0	1	0	1
-24 to -22	0	0	1	0	0
-32 to -25	0	0	0	1	1
-36 to -33	0	0	0	1	0
-42 to -37	0	0	0	0	1
-48 to -43	0	0	0	0	0

**Table 1. Volume Status LED Decodes**

Treble or Bass Boost [dB]	LED Pattern				
	D20	D21	D22	D23	D24
0	1	1	1	1	1
1	1	1	1	1	0
2	1	1	1	0	1
3	1	1	1	0	0
4	1	1	0	1	1
5	1	1	0	1	0
6	1	1	0	0	1
7	1	1	0	0	0
8	1	0	1	1	1
9	1	0	1	1	0
10	1	0	1	0	1
11	1	0	1	0	0
12	1	0	0	1	1

**Table 2. Treble/Bass Boost Status LED Decodes**



### 4.3 CS44L11 Initialization

Table 3 shows the CS44L11 register settings at startup. Refer to the CS44L11 Data Sheet for more information.

Addr	Function	7	6	5	4	3	2	1	0
2h	Power and Muting Control default	SZC1 1	SZC0 0	PDN 1	FLT 0	RUPBYP 0	RDNBYP 0	Reserved 0	Reserved 0
3h	Channel A Volume Control default	VOLA7 1	VOLA6 1	VOLA5 1	VOLA4 0	VOLA3 1	VOLA2 0	VOLA1 0	VOLA0 0
4h	Channel B Volume Control default	VOLB7 0	VOLB6 0	VOLB5 0	VOLB4 0	VOLB3 0	VOLB2 0	VOLB1 0	VOLB0 0
5h	Tone Control default	BB3 0	BB2 0	BB1 0	BB0 0	TB3 0	TB2 0	TB1 0	TB0 0
6h	Mode Control 1 default	BBCF1 0	BBCF0 0	TBCF1 0	TBCF0 0	TC1 0	TC0 0	TC_EN 1	LIM_EN 0
7h	Limiter Attack Rate default	ARATE7 0	ARATE6 0	ARATE5 0	ARATE4 1	ARATE3 0	ARATE2 0	ARATE1 0	ARATE0 0
8h	Limiter Release Rate default	RRATE7 0	RRATE6 0	RRATE5 1	RRATE4 0	RRATE3 0	RRATE2 0	RRATE1 0	RRATE0 0
9h	Volume and Mixing Control default	IS1 0	IS0 0	RMP_SP1 0	RMP_SP0 0	ATAPI3 1	ATAPI2 0	ATAPI1 0	ATAPI0 1
Ah	Mode Control2 default	MCLKDIV 0	CLKDV1 0	CLKDV0 0	DBS 0	FRQSFT1 0	FRQSFT0 0	DEM1 0	DEM0 0
Bh	Mode Control 3 default	DIF1 0	DIF0 0	A=B 1	VCBYP 0	CP_EN 1	FREEZE 0	Reserved 0	Reserved 0
Ch	Revision Indicator default	Reserved 0	Reserved 0	Reserved 0	Reserved 0	REV3 Read Only	REV2 Read Only	REV1 Read Only	REV0 Read Only

**Table 3. Initial CS44L11 Register Settings**

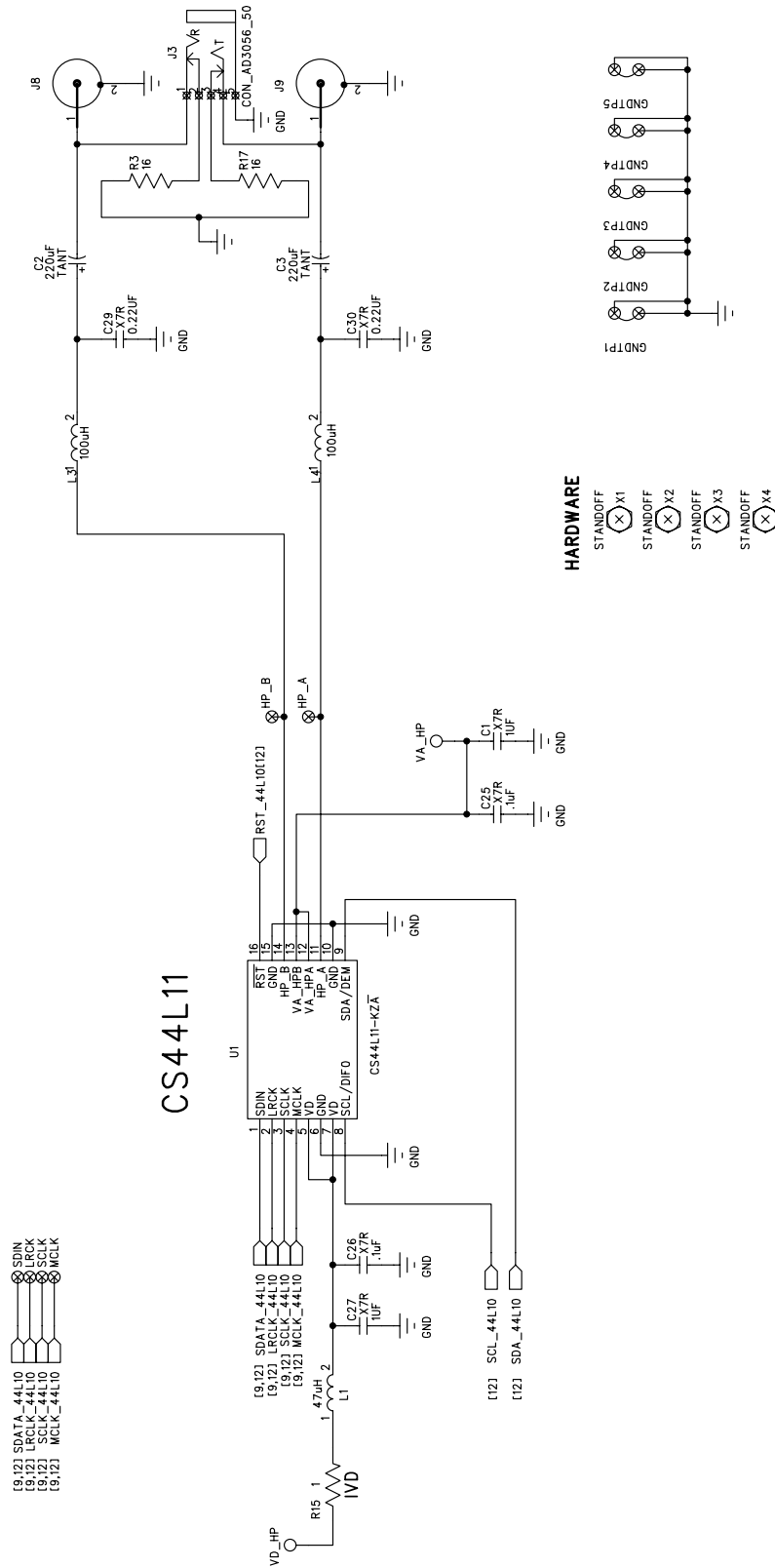

**Figure 1. CS44L11 PWM Headphone Amplifier**

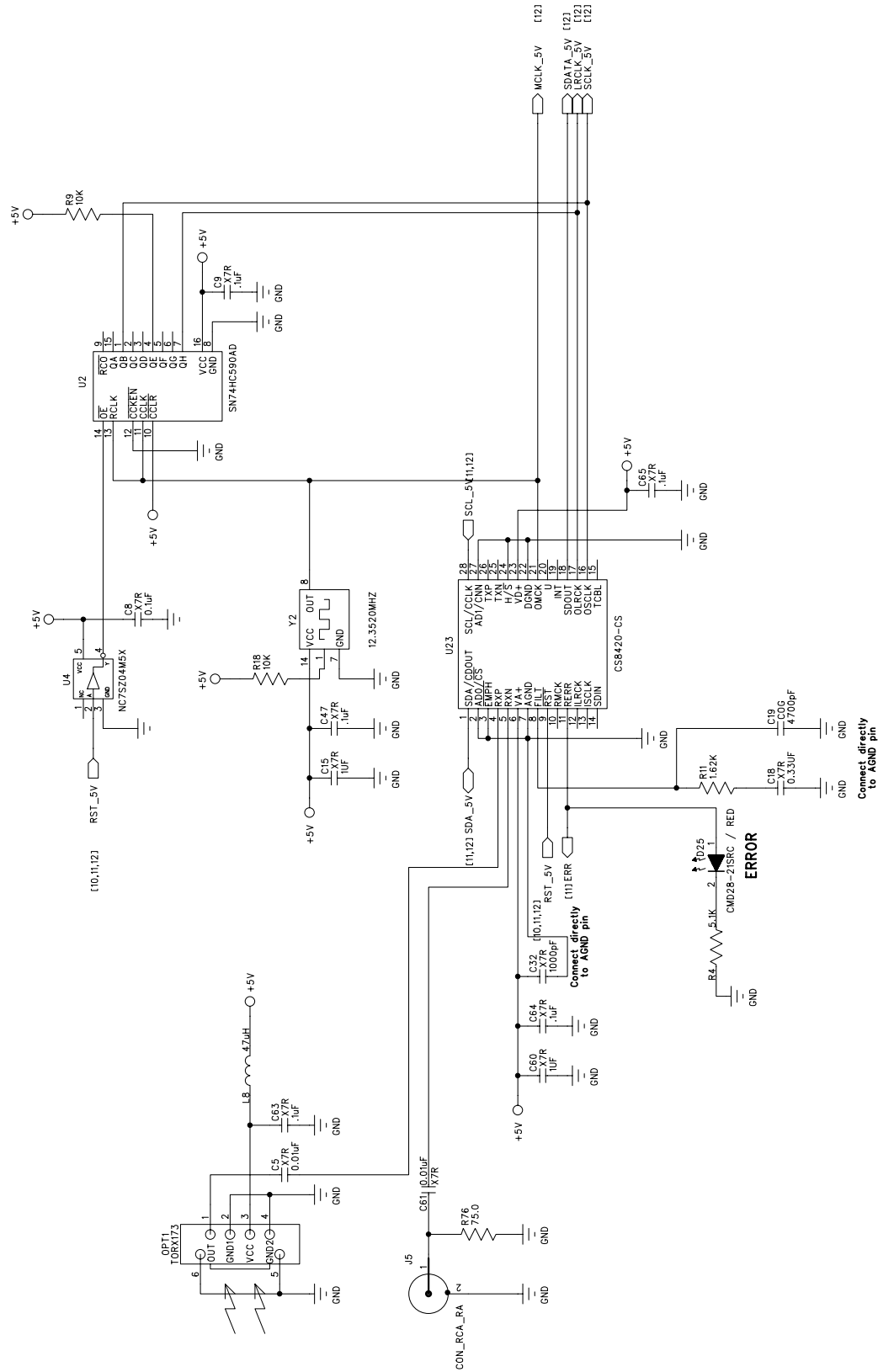
**Figure 2. CS8420 S/PDIF Receiver and Sample Rate Converter**

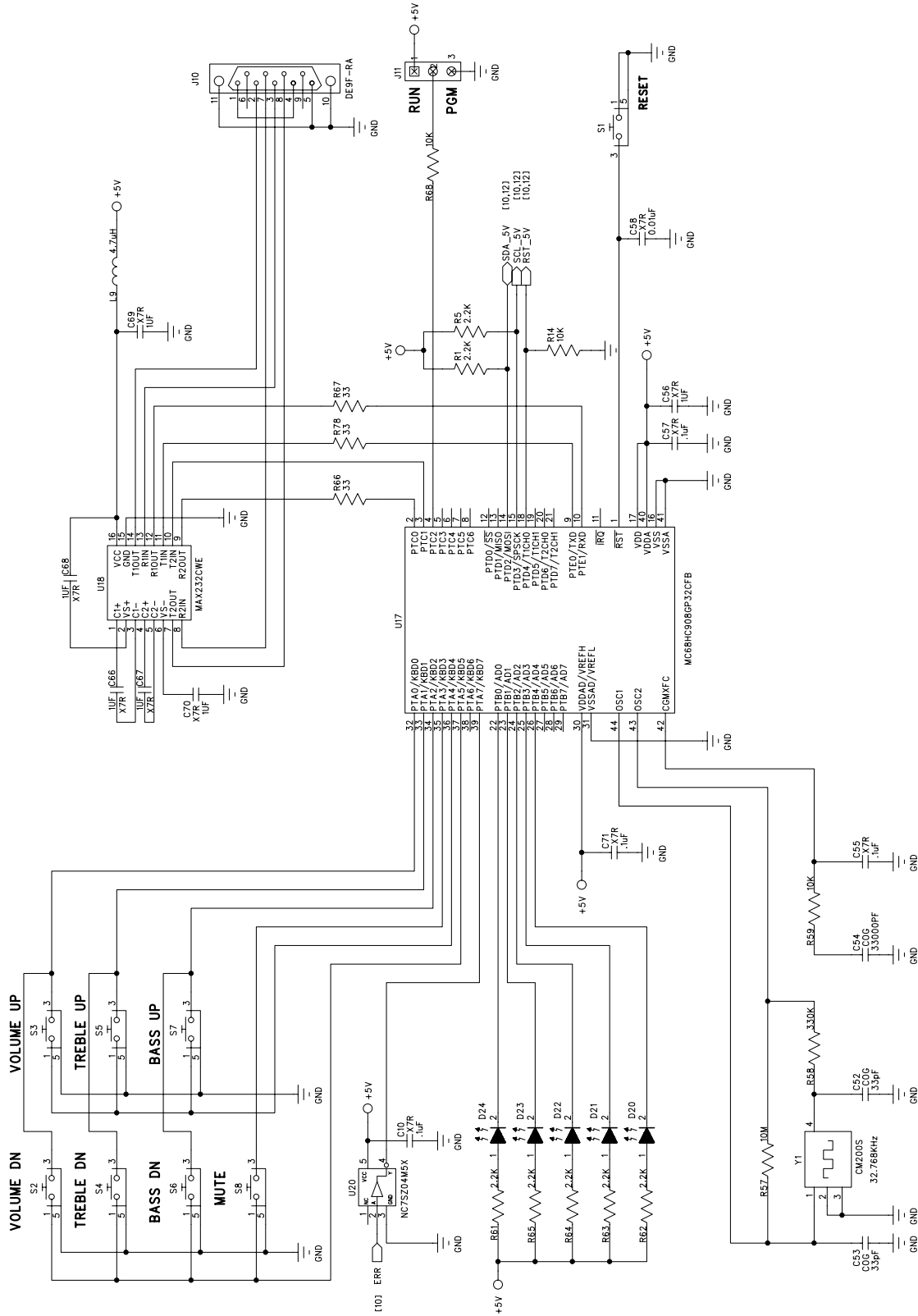
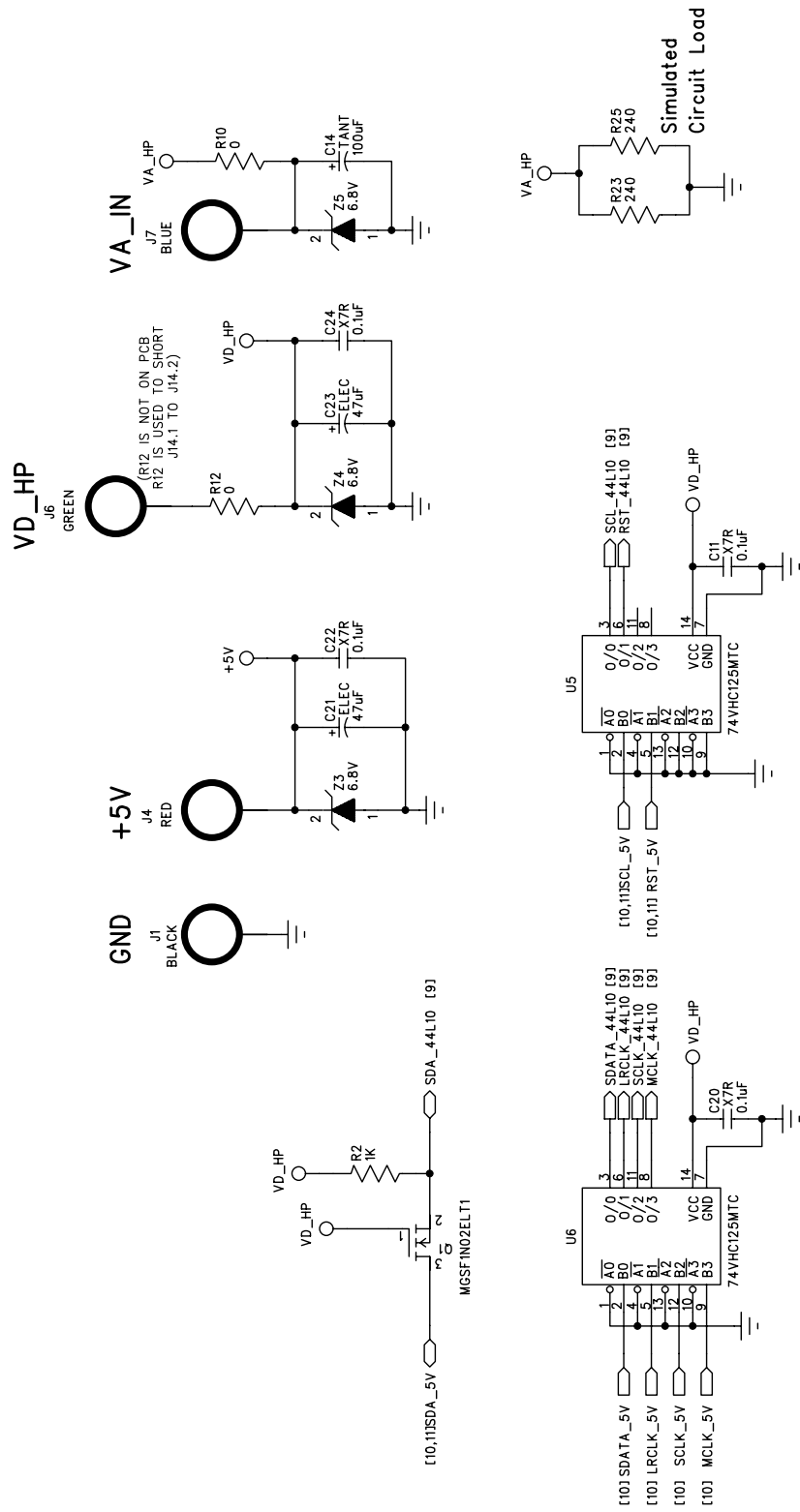

Figure 3. Microcontroller

**Figure 4. Power Supply**

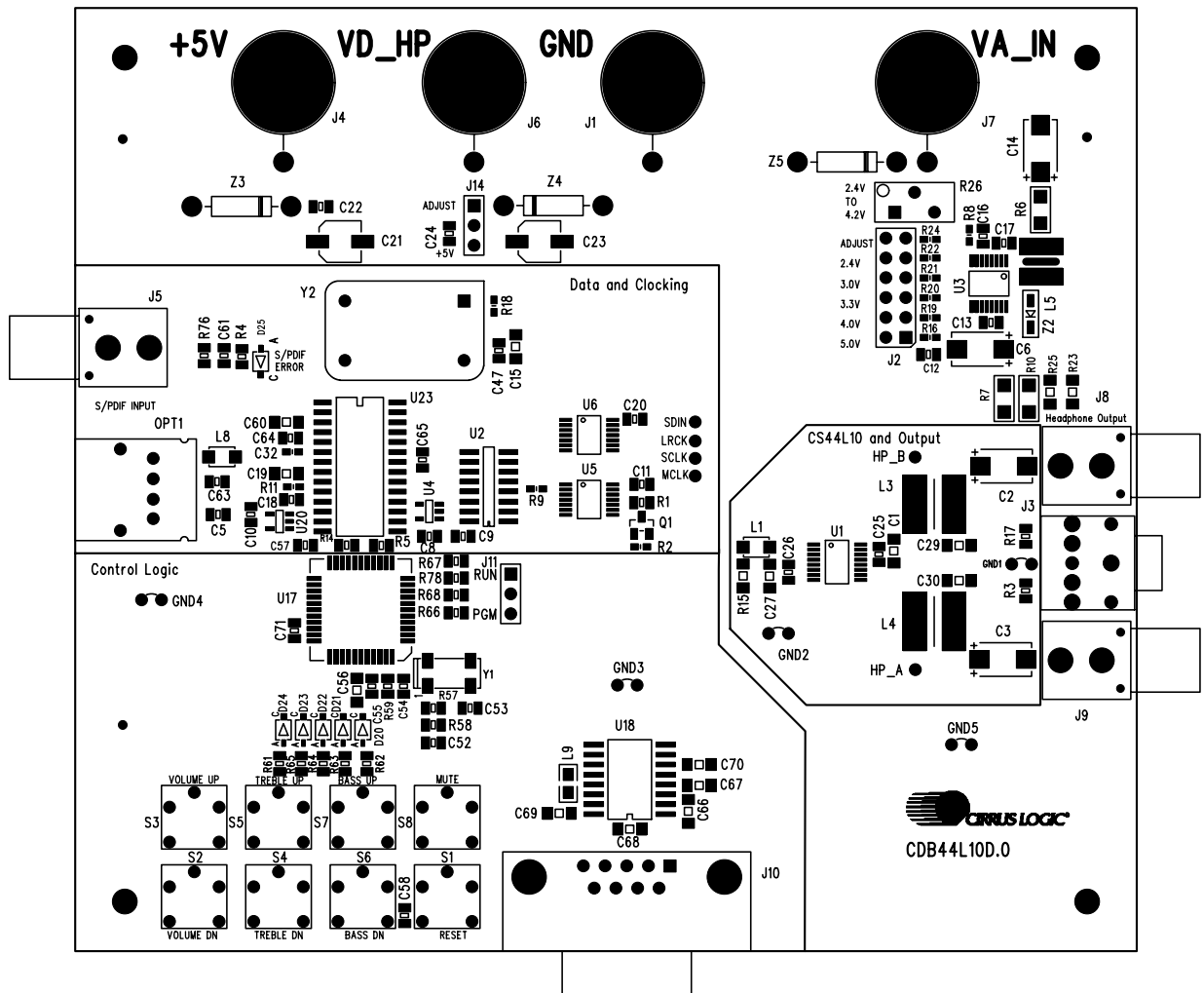

Figure 5. Assembly Drawing

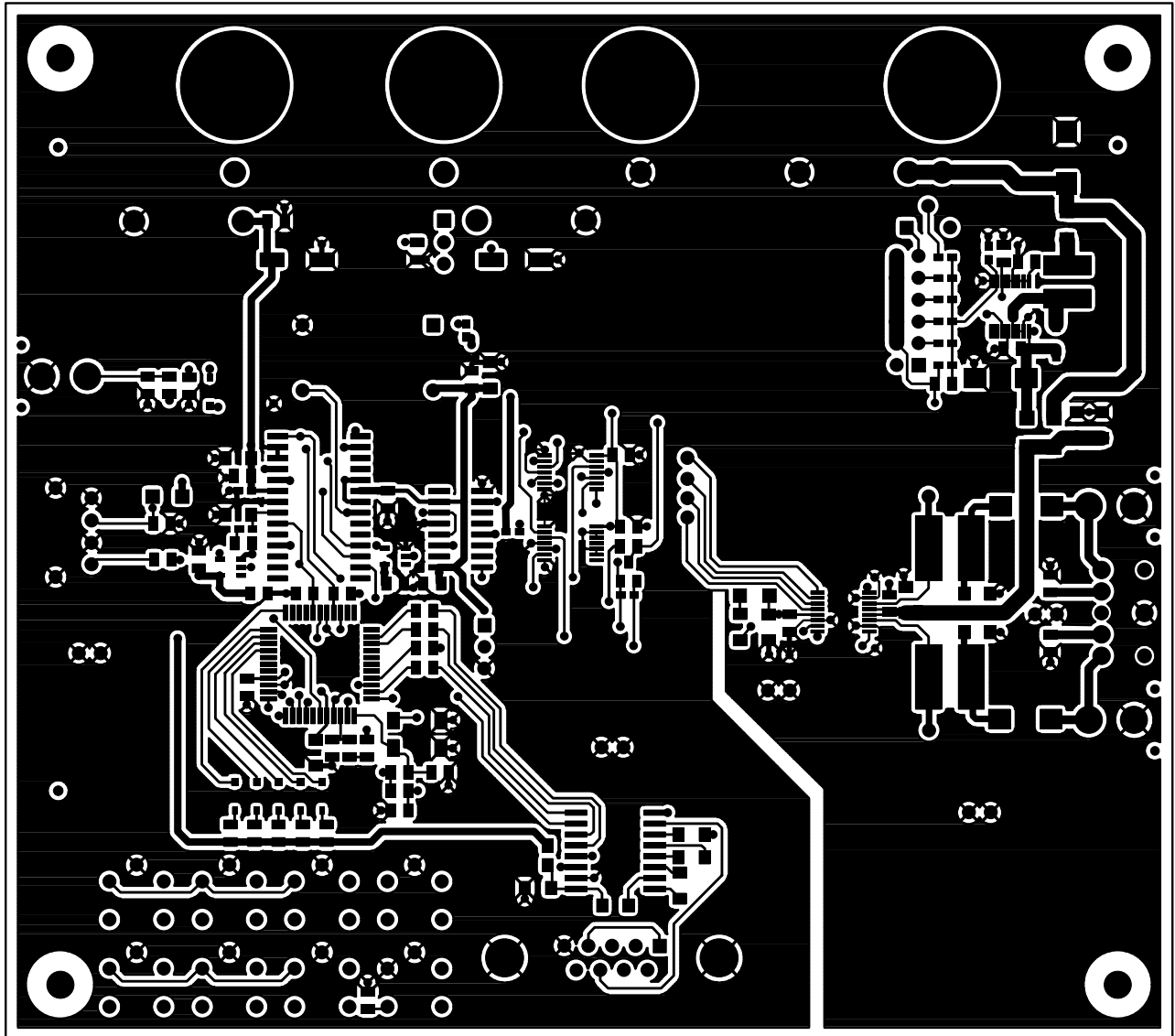

Figure 6. Top Layer

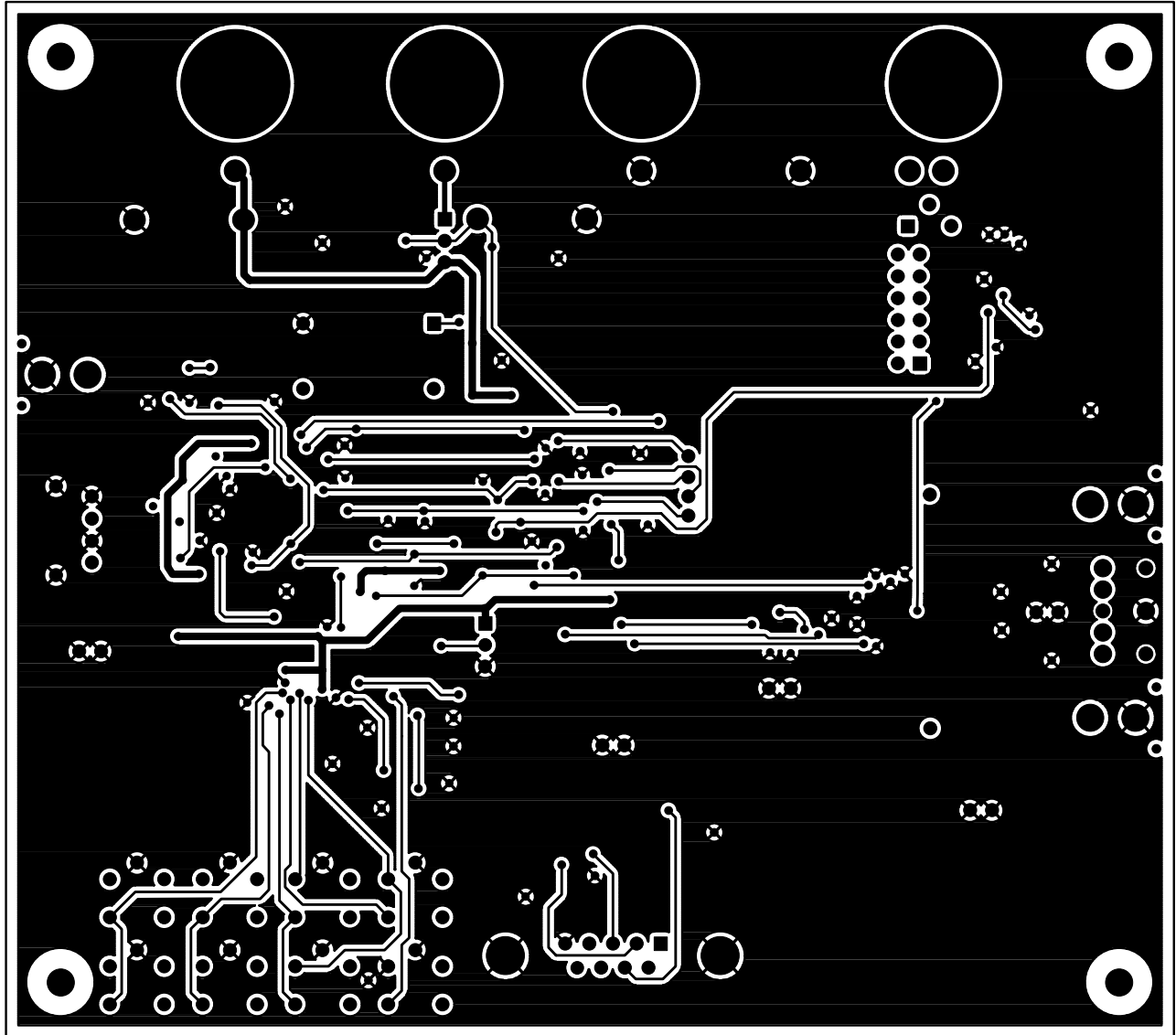
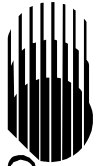

Figure 7. Bottom Layer



## 5. BILL OF MATERIALS

Item	Rev	Description	Qty	Reference Designator	MFG	MFG P/N
1	A	CAP 1 $\mu$ F 10% 16V X7R 0805	9	C1 C15 C56 C60 C66 C67 C68 C69 C70	KEMET	C0805C105K4RAC
2	A	CAP 220 $\mu$ F 10% 6V TANT CASE D	2	C2 C3	KEMET	T491D227K006AS
3	A	CAP 0.01 $\mu$ F 10% 50V X7R 0805	2	C5 C61	KEMET	C0805C103K5RAC
4	A	CAP 100 $\mu$ F 20% 6.3V TANT CASE C	0	C6	VISHAY SPRAGUE	595D107X06R3C2T
5	A	CAP 0.1 $\mu$ F 10% 50V X7R 0805	16	C8 C9 C10 C11 C20 C22 C24 C25 C26 C47 C55 C57 C63 C64 C65 C71	KEMET	C0805C104K5RAC
6	A	CAP 0.1 $\mu$ F 10% 50V X7R 0805	0	C12 C16	KEMET	C0805C104K5RAC
7	A	CAP 0.33 $\mu$ F 10% 16V X7R 0805	0	C13 C17	KEMET	C0805C334K4RAC
8	A	CAP, 100 $\mu$ F 20% 6.3V TANT CASE C	1	C14	VISHAY SPRAGUE	595D107X06R3C2T
9	A	CAP 0.33 $\mu$ F 10% 16V X7R 0805	1	C18	KEMET	C0805C334K4RAC
10	A	CAP 4700 pF 5% 50V C0G 1206	1	C19	KEMET	C1206C472J5GAC
11	A	CAP 47 $\mu$ F 20% 16V ELEC CASE C	2	C21 C23	PANASONIC	ECEV1CA470WR
12	A	CAP 1 $\mu$ F 10% 25V X7R 1206	1	C27	KEMET	C1206C105K3RAC
13	A	CAP 0.22 $\mu$ F 10% 50V X7R 1206	2	C29 C30	KEMET	C1206C224K5RAC
14	A	CAP 1000 pF 5% 50V X7R 0603	1	C32	KEMET	C0603C102J5RAC
15	A	CAP 33 pF 10% 50V C0G 0805	2	C52 C53	KEMET	C0805C330K5GAC
16	A	CAP 0.033 $\mu$ F 10% 50V X7R 0805	1	C54	KEMET	C0805C333K5RAC
17	A	CAP 0.01 $\mu$ F 5% 50V X7R 0805	1	C58	KEMET	C0805C103J5RAC
18	A	LED CLR GRN, 2.1V 1mA .16MCD, SMD	5	D20 D21 D22 D23 D24	CHICAGO MINIATURE	CMD28-21VGC/TR8/T1
19	A	LED CLR SRED, 1.7V 1mA 1.6MCD, SMD	1	D25	CHICAGO MINIATURE	CMD28-21SRC/TR8/T1
20	A	WIRE, JUMPER 2P, 0.1 <sup>mm</sup> CTR, BRASS	5	GNDTP1 GNDTP2 GNDTP3 GNDTP4 GNDTP5	COMPONENTS COR- PORATION	TP-101-10
21	A	CONN, TEST PT, .1 <sup>mm</sup> CTR TIN PLATE BLK	2	HP_A HP_B	KEYSTONE	5001
22	A	CONN, BPOST 2 <sup>mm</sup> SILV, NYLON INS, BLK	1	J1	JOHNSON COMPO- NENTS	111-0103-001
23	A	HDR 6x2, MLE .1 <sup>mm</sup> CTR, S GLD	0	J2	SAMTEC	TSW-106-07-G-D
24	A	JACK STEREO HEADPHONE	1	J3	A/D ELECTRONICS	3056-50
25	A	CONN, BPOST 2 <sup>mm</sup> SILV, NYLON INS, RED	1	J4	JOHNSON COMPO- NENTS	111-0102-001



Item	Rev	Description	Qty	Reference Designator	MFG	MFG P/N
26	A	JACK RCA, RA-BLK, PHONO, GLD TABS	3	J5 J8 J9	A/D ELECTRONICS	ARJ-2018-NIL-1-NIL
27	A	CONN, BPOST 2" SILV, NYLON INS, GRN	1	J6	JOHNSON COMPONENTS	111-0104-001
28	A	CONN, BPOST 2" SILV, NYLON INS, BLU	1	J7	JOHNSON COMPONENTS	111-0110-001
29	A	CONN, DE9 FMLE, RT. ANGL	1	J10	ADAM TECH	DE09-SL-24
30	A	HDR 3x1, MLE .1" CTR, S GLD	1	J11	SAMTEC	TSW-103-07-G-S
31	A	HDR 3x1, MLE .1" CTR, S GLD	0	J14	SAMTEC	TSW-103-07-G-S
32	A	IND 47 $\mu$ H, 10%, 1210	2	L1 L8	PANASONIC	ELJFA470KF
33	A	IND 100 $\mu$ H 20% CTGSR74B SERIES SM	2	L3 L4	CENTRAL TECHNOLOGIES	CTGSR74B-101M
34	A	IND 220 $\mu$ H 20% CTGS54 SERIES SM	0	L5	CENTRAL TECHNOLOGIES	CTGS54-220M
35	A	IND 4.7 $\mu$ H 10% 0805	1	L9	PANASONIC	ELJFD4R7KF
36	A	CONN, TEST PT, .1" CTR TIN PLATE BLK	0	LRCK MCLK SCLK SDIN	KEYSTONE	5001
37	A	OPTICAL RCVR, 6Mb/s, 7V 20MA 10M	1	OPT1	TOSHIBA	TORX173
38	A	TRAN, MOSFET nCHAN 750mA 20V SOT-23	1	Q1	MOTOROLA	MGSF1N02ELT1
39	A	RES 2.2k OHM 1/8W 5% 0805 FILM	7	R1 R5 R61 R62 R63 R64 R65	DALE	CRCW0805222J
40	A	RES 1k OHM 1/16W 1% 0603 FILM	1	R2	DALE	CRCW06031001F
41	A	RES 16 OHM 1/8W 5% 0805 FILM	2	R3 R17	DALE	CRCW0805160J
42	A	RES 5.1k OHM 1/8W 5% 0805 FILM	1	R4	DALE	CRCW0805512J
43	A	RES 0 OHM 1/8W 1% 1206 FILM	0	R6 R7	DALE	CRCW1206000Z
44	A	RES 51.1k OHM 1/16W 1% 0603 FILM	0	R8	DALE	CRCW06035112F
45	A	RES 10k OHM 1/16W 1% 0603 FILM	2	R9 R18	DALE	CRCW06031002F
46	A	RES 0 OHM 1/8W 1% 1206 FILM	1	R10	DALE	CRCW1206000Z
47	A	RES 1.62k OHM 1/16W 1% 0603 FILM	1	R11	DALE	CRCW06031621F
48	A	RES 0 OHM 1/10W 1% 0805 FILM	1	R12	DALE	CRCW0805000Z
49	A	RES 10k OHM 1/8W 5% 0805 FILM	3	R14 R59 R68	VISHAY	CRCW0805103J
50	A	RES 1 OHM 1/8W 5% 1206 FILM	1	R15	DALE	CRCW12061R0J
51	A	RES 158k OHM 1/16W 1% 0603 FILM	0	R16	DALE	CRCW06031583F
52	A	RES 432k OHM 1/16W 1% 0603 FILM	0	R19	DALE	CRCW06034323F



Item	Rev	Description	Qty	Reference Designator	MFG	MFG P/N
53	A	RES 191k OHM 1/16W 1% 0603 FILM	0	R20	DALE	CRCW06031913F
54	A	RES 137k OHM 1/16W 1% 0603 FILM	0	R21	DALE	CRCW06031373F
55	A	RES 69.8k OHM 1/16W 1% 0603 FILM	2	R22 R24	DALE	CRCW06036982F
56	A	RES 240 OHM 1/8W 5% 1206 FILM	2	R23 R25	DALE	CRCW1206241J
57	A	RES POT 500K 10%10TURN TOP-ADJ TH	0	R26	BOURNS	3266W-1-504
58	A	RES 10M OHM 1/10W 1% 0805 FILM	1	R57	DALE	CRCW08051005F
59	A	RES 330k OHM 1/8W 5% 0805 FILM	1	R58	DALE	CRCW0805334J
60	A	RES 33 OHM 1/8W 5% 0805 FILM	3	R66 R67 R78	PANASONIC	ERJ6GEYJ330V
61	A	RES 75 OHM 1/10W 1% 0805 FILM	1	R76	DALE	CRCW080575R0F
62	A	SWITCH 0/1 TACT, W/ESD	8	S1 S2 S3 S4 S5 S6 S7 S8	C&K	PTS645TL50
63	A	IC, DIGITAL PWM HEADPHONE MONITOR,T	1	U1	CIRRUS LOGIC	CS44L11-KZ/A
64	A	IC LOG 8-BIT W/3-ST OUT REG SOIC16	1	U2	TEXAS INSTRUMENTS	SN74HC590AD
65	A	IC LIN H-CUR L-NOISE CNVTR SSOP16	0	U3	MAXIM	MAX1706EEE
66	A	IC LOG, INVERT, 5P, UHS TINY, SOT23	2	U4 U20	FAIRCHILD SEMI-CONDUCTOR	NC7SZ04M5X
67	A	IC LOG, 4 BUF W/3ST 14P TSSOP	2	U5 U6	FAIRCHILD SEMI-CONDUCTOR	74VHC125MTC
68	A	IC PGM, mCNTR 32K PQFP44	1	U17	MOTOROLA	MC68HC908GP32CFB
69	A	IC LNR 5V MCH RS-232 DRV/RCV SOIC16	1	U18	MAXIM	MAX232CWE
70	D1	IC CRUS DIG AUD SAMP RTE CNV SOIC28	1	U23	CRYSTAL SEMICONDUCTOR	CS8420-CS/D1
71	A	SPCR, STANDOFF 4-40 THR, 0.875"L	4	X1 X2 X3 X4	KEYSTONE	1809
72	A	OSC 32.768KHZ 20ppm 8mm x 3.8mm SMT	1	Y1	CITIZEN	CM200S32.768KDZFT
73	A	OSC 12.352MHZ 50PPM 5V FULL DIP14	1	Y2	CAL CRYSTAL	CX21AF-12.3520MHZ
74	A	DIODE, SCHTKY POWER RECT, SOD123	0	Z2	MOTOROLA	MBR0520LT1
75	A	DIODE TRANS. SUPPRESSOR, 6.8V, 600W	3	Z3 Z4 Z5	MOTOROLA	P6KE6.8
76	D	CONN, SHUNT, 2P, .1"CTR, BLK	3	XJ2,XJ11,XJ14	MOLEX	15-29-1025



## 6. REVISION HISTORY

Release	Date	Changes
DB1	April 2004	Initial Release

Table 4. Revision History

---

### Contacting Cirrus Logic Support

For all product questions and inquiries contact a Cirrus Logic Sales Representative.

To find the one nearest to you go to [www.cirrus.com](http://www.cirrus.com)

---

#### IMPORTANT NOTICE

Cirrus Logic, Inc. and its subsidiaries ("Cirrus") believe that the information contained in this document is accurate and reliable. However, the information is subject to change without notice and is provided "AS IS" without warranty of any kind (express or implied). Customers are advised to obtain the latest version of relevant information to verify, before placing orders, that information being relied on is current and complete. All products are sold subject to the terms and conditions of sale supplied at the time of order acknowledgment, including those pertaining to warranty, patent infringement, and limitation of liability. No responsibility is assumed by Cirrus for the use of this information, including use of this information as the basis for manufacture or sale of any items, or for infringement of patents or other rights of third parties. This document is the property of Cirrus and by furnishing this information, Cirrus grants no license, express or implied under any patents, mask work rights, copyrights, trademarks, trade secrets or other intellectual property rights. Cirrus owns the copyrights associated with the information contained herein and gives consent for copies to be made of the information only for use within your organization with respect to Cirrus integrated circuits or other products of Cirrus. This consent does not extend to other copying such as copying for general distribution, advertising or promotional purposes, or for creating any work for resale.

CERTAIN APPLICATIONS USING SEMICONDUCTOR PRODUCTS MAY INVOLVE POTENTIAL RISKS OF DEATH, PERSONAL INJURY, OR SEVERE PROPERTY OR ENVIRONMENTAL DAMAGE ("CRITICAL APPLICATIONS"). CIRRUS PRODUCTS ARE NOT DESIGNED, AUTHORIZED OR WARRANTED FOR USE IN AIRCRAFT SYSTEMS, MILITARY APPLICATIONS, PRODUCTS SURGICALLY IMPLANTED INTO THE BODY, LIFE SUPPORT PRODUCTS OR OTHER CRITICAL APPLICATIONS (INCLUDING MEDICAL DEVICES, AIRCRAFT SYSTEMS OR COMPONENTS AND PERSONAL OR AUTOMOTIVE SAFETY OR SECURITY DEVICES). INCLUSION OF CIRRUS PRODUCTS IN SUCH APPLICATIONS IS UNDERSTOOD TO BE FULLY AT THE CUSTOMER'S RISK AND CIRRUS DISCLAIMS AND MAKES NO WARRANTY, EXPRESS, STATUTORY OR IMPLIED, INCLUDING THE IMPLIED WARRANTIES OF MERCHANTABILITY AND FITNESS FOR PARTICULAR PURPOSE, WITH REGARD TO ANY CIRRUS PRODUCT THAT IS USED IN SUCH A MANNER. IF THE CUSTOMER OR CUSTOMER'S CUSTOMER USES OR PERMITS THE USE OF CIRRUS PRODUCTS IN CRITICAL APPLICATIONS, CUSTOMER AGREES, BY SUCH USE, TO FULLY INDEMNIFY CIRRUS, ITS OFFICERS, DIRECTORS, EMPLOYEES, DISTRIBUTORS AND OTHER AGENTS FROM ANY AND ALL LIABILITY, INCLUDING ATTORNEYS' FEES AND COSTS, THAT MAY RESULT FROM OR ARISE IN CONNECTION WITH THESE USES.

Cirrus Logic, Cirrus, and the Cirrus Logic logo designs and PopGuard are trademarks of Cirrus Logic, Inc. All other brand and product names in this document may be trademarks or service marks of their respective owners.

I<sup>2</sup>C is a registered trademark of Philips Semiconductor. Purchase of I<sup>2</sup>C Components of Cirrus Logic, Inc., or one of its sublicensed Associated Companies conveys a license under the Philips I<sup>2</sup>C Patent Rights to use those components in a standard I<sup>2</sup>C system.