

Right Angle Twist-On Plug - Field Installable - 1 Piece

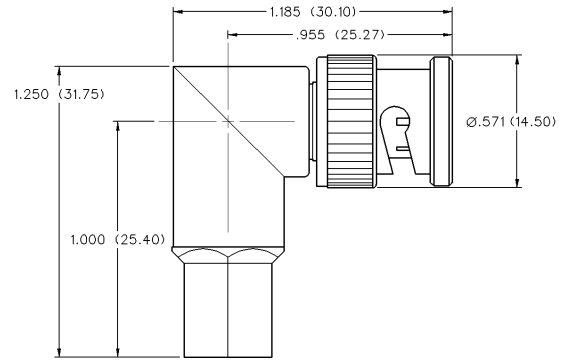

INCHES (MILLIMETERS)
CUSTOMER DRAWINGS AVAILABLE UPON REQUEST



PART NUMBER	CABLE TYPE	WIRE GAUGE	WIRE DECIMAL	JACKET O.D.
CPFI-RA-2	RG-59, 62	22	.025 (0.64)	.220 (5.59)-.250 (6.35)

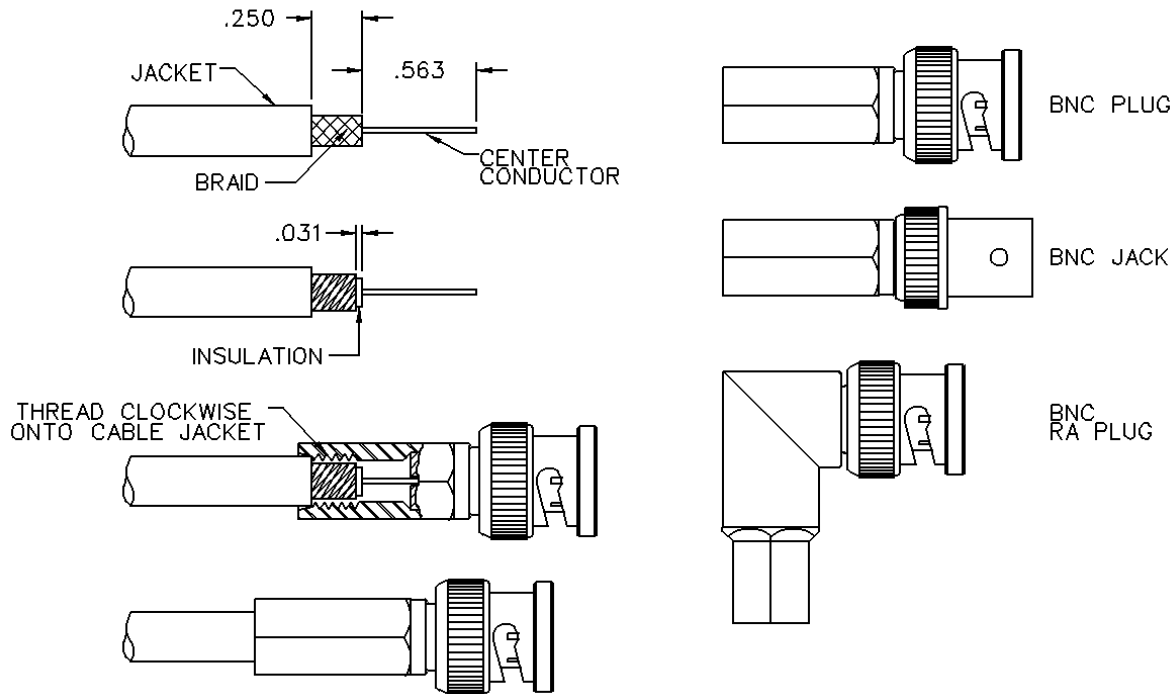

1. Identify connector parts. (1 piece)
2. Trim cable as shown. Taking care not to nick the center conductor or outer braid.
3. Use the fingernail to rotate the outer braids clockwise such that 1/32" of the insulation is bared. Then in the same direction rub the stray braids flat. (Stray or loose braids can cause shorts.)
4. Gently insert the center conductor down the back end of the connector, feeling it into the guide hole. (If the center conductor is not in place, approximately 1/8" of the center conductor - the part closest to the dielectric - will still be viewable.)
5. Firmly push the cable home (a slight clockwise twist may help with insertion). Then screw the connector on the cable in a clockwise direction until it is snugly attached to the jacket. (Right angle connectors provide a lever to aid in twist, therefore do not over twist, which may cause the jacket and braids to eventually wear out.)

CABLE ASSEMBLY CAUTIONS:

- Series are designed for solid center conductor wire. RG-58 cable will need the center conductor tin dipped (ONLY if it is not a solid center conductor). This is necessary to provide extra support for step 5.
- RG-MATV-59 cable will require caution when using the fingernail to rotate the braids on cable types that include aluminum foil for the outer conductor. DO NOT tear or rip the foil conductor to the 1/32" as suggested by step 3.
- RG-62 cable includes trimming the filament to 9/16" as well. Make sure that the filament does not unravel so that it protrudes past this dimension.

Part Number	Cable Type	Wire Gauge	Wire Decimal	Jacket O.D.
CPFI-RA-2	RG-59, 62	20	.025 (0.64)	.220 (5.59)-.250 (6.35)

BNC Connectors

Specifications



INCHES (MILLIMETERS)
CUSTOMER DRAWINGS AVAILABLE UPON REQUEST

The BNC series connector is a commercial quality product that intermates with all standard double bayonet stud BNC designs. All contacts are captivated for ruggedness. The 50 ohm and 75 ohm interfaces are intermateable and provide quick, reliable connections for instrumentation, medical and LAN applications.

Specifications*

50 Ohm BNC

Electrical Characteristics

Impedance: 50 Ohm nominal

Frequency range: 0-4 GHz

Working voltage: 500 volts RMS at sea level

Dielectric withstanding voltage: 1500 volts RMS at sea level

Corona level: 375 volts minimum at 70,000 feet

Contact resistance: Outer - 0.2 milliohms maximum
Center - 2.1 milliohms maximum

Insulation resistance: 5000 megohms minimum

Environmental Characteristics

Recommended temperature range: -55°C to +85°C

Moisture resistance: MIL-STD-202

Mechanical Characteristics

Durability: 500 cycles

Force to engage/disengage: 3 lbs. maximum

Cable retention: 20 lbs., RG-58 C/U cable

Materials

Body: Zinc or brass

Contact: Brass, beryllium copper or phosphor bronze

Spring Washer: Beryllium copper

Crimp sleeve: Brass

Insulator: Delrin® or TPX Polymethylpentene

Plating: Body - Nickel (except where noted)

Crimp sleeve - Nickel

Contact - Gold

* These values are typical and may not apply to all connectors.