

Data Sheet

Description

The MSA-0770 is a high performance silicon bipolar Monolithic Microwave Integrated Circuit (MMIC) housed in a hermetic, high reliability package. This MMIC is designed for use as a general purpose 50Ω gain block. Typical applications include narrow and broad band IF and RF amplifiers in industrial and military applications.

The MSA-series is fabricated using Avago's 10 GHz f_T , 25 GHz f_{MAX} , silicon bipolar MMIC process which uses nitride self-alignment, ion implantation, and gold metallization to achieve excellent performance, uniformity and reliability. The use of an external bias resistor for temperature and current stability also allows bias flexibility.

70 mil Package

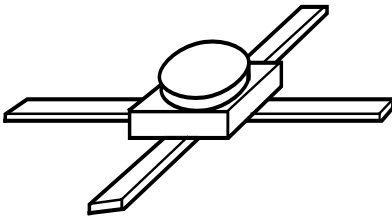

Features

- Cascadable 50Ω Gain Block
- Low Operating Voltage: 4.0 V Typical V_d
- 3 dB Bandwidth: DC to 2.5 GHz
- 13.0 dB Typical Gain at 1.0 GHz
- Unconditionally Stable ($k > 1$)
- Hermetic, Gold-ceramic Microstrip Package

Typical Biasing Configuration

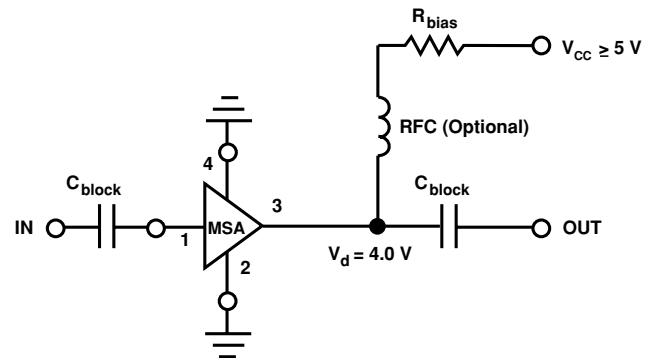

MSA-0770 Absolute Maximum Ratings

Parameter	Absolute Maximum ^[1]
Device Current	60 mA
Power Dissipation ^[2,3]	275 mW
RF Input Power	+13 dBm
Junction Temperature	200°C
Storage Temperature	-65 to 200°C

Thermal Resistance^[2,4]:

$$\theta_{jc} = 130^{\circ}\text{C/W}$$

Notes:

1. Permanent damage may occur if any of these limits are exceeded.
2. $T_{\text{CASE}} = 25^{\circ}\text{C}$.
3. Derate at 7.7 mW/°C for $T_C > 164^{\circ}\text{C}$.
4. This small spot size of this technique results in a higher, though more accurate determination of θ_{jc} than do alternate methods.

Electrical Specifications^[1], $T_A = 25^{\circ}\text{C}$

Symbol	Parameters and Test Conditions: $I_d = 22 \text{ mA}$, $Z_0 = 50 \Omega$	Units	Min.	Typ.	Max.
G_p	Power Gain ($ S_{21} ^2$) $f = 0.1 \text{ GHz}$	dB	12.5	13.5	14.5
ΔG_p	Gain Flatness $f = 0.1 \text{ to } 1.5 \text{ GHz}$	dB		± 0.6	± 1.0
$f_{3 \text{ dB}}$	3 dB Bandwidth	GHz		2.5	
VSWR	Input VSWR $f = 0.1 \text{ to } 2.5 \text{ GHz}$			2.0:1	
	Output VSWR $f = 0.1 \text{ to } 2.5 \text{ GHz}$			1.6:1	
NF	50 Ω Noise Figure $f = 1.0 \text{ GHz}$	dB		4.5	
$P_{1 \text{ dB}}$	Output Power at 1 dB Gain Compression $f = 1.0 \text{ GHz}$	dBm		5.5	
IP_3	Third Order Intercept Point $f = 1.0 \text{ GHz}$	dBm		19.0	
t_D	Group Delay $f = 1.0 \text{ GHz}$	psec		130	
V_d	Device Voltage	V	3.6	4.0	4.4
dV/dT	Device Voltage Temperature Coefficient	mV/°C		-7.0	

Note:

1. The recommended operating current range for this device is 15 to 40 mA.
Typical performance as a function of current is on the following page.

MSA-0770 Typical Scattering Parameters ($Z_0 = 50 \Omega$, $T_A = 25^\circ\text{C}$, $I_d = 22 \text{ mA}$)

Freq. GHz	S_{11}			S_{21}			S_{12}		S_{22}	
	Mag	Ang	dB	Mag	Ang	dB	Mag	Ang	Mag	Ang
0.1	.04	-7	13.5	4.74	175	-18.6	.118	2	.20	-10
0.2	.05	-11	13.5	4.72	170	-18.4	.120	2	.19	-18
0.4	.06	-24	13.4	4.70	160	-18.4	.121	6	.20	-34
0.6	.08	-38	13.4	4.65	151	-18.1	.124	7	.21	-50
0.8	.10	-48	13.2	4.58	141	-17.8	.133	9	.23	-76
1.0	.12	-58	13.0	4.47	131	-17.5	.133	9	.23	-76
1.5	.20	-82	12.3	4.12	107	-16.6	.148	10	.23	-101
2.0	.30	-107	11.6	3.82	85	-15.7	.163	8	.22	-116
2.5	.37	-123	10.4	3.33	70	-15.3	.171	7	.19	-116
3.0	.42	-140	9.0	2.83	52	-15.4	.170	3	.20	-111
3.5	.46	-154	7.7	2.42	37	-15.4	.170	1	.23	-107
4.0	.47	-167	6.4	2.08	23	-15.5	.169	-4	.29	-107
5.0	.47	163	4.2	1.63	-1	-15.5	.167	-9	.35	-116
6.0	.51	131	2.3	1.30	-23	-15.9	.160	-11	.38	-133

Typical Performance, $T_A = 25^\circ\text{C}$

(unless otherwise noted)

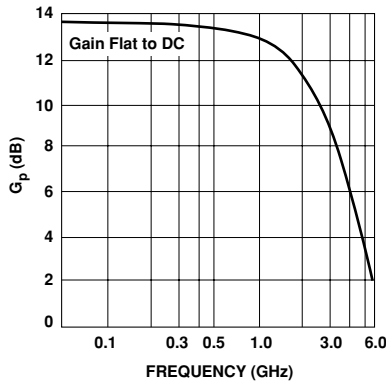

Figure 1. Typical Power Gain vs. Frequency, $I_d = 22 \text{ mA}$.

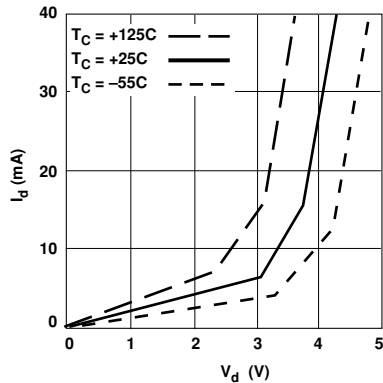

Figure 2. Device Current vs. Voltage.

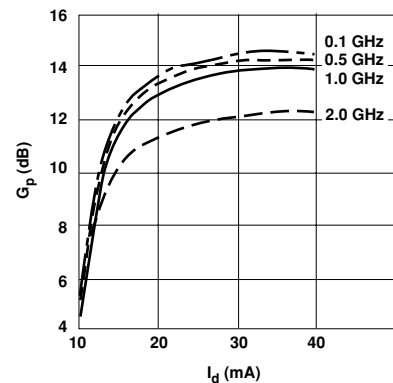

Figure 3. Power Gain vs. Current.

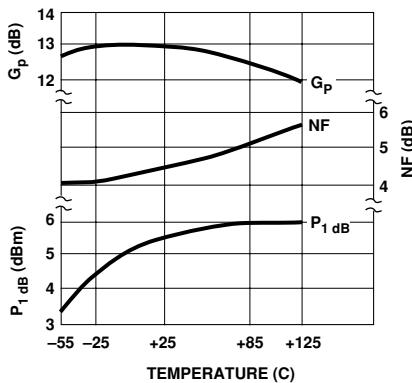

Figure 4. Output Power at 1 dB Gain Compression, NF and Power Gain vs. Case Temperature, $f = 1.0 \text{ GHz}$, $I_d = 22 \text{ mA}$.

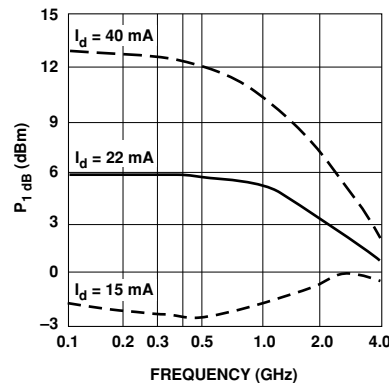

Figure 5. Output Power at 1 dB Gain Compression vs. Frequency.

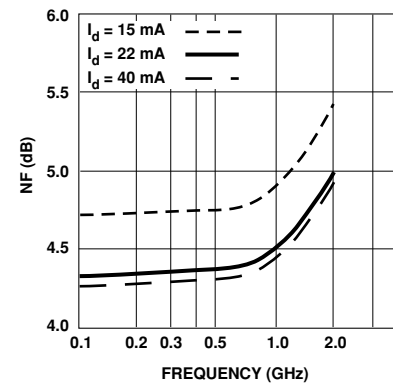
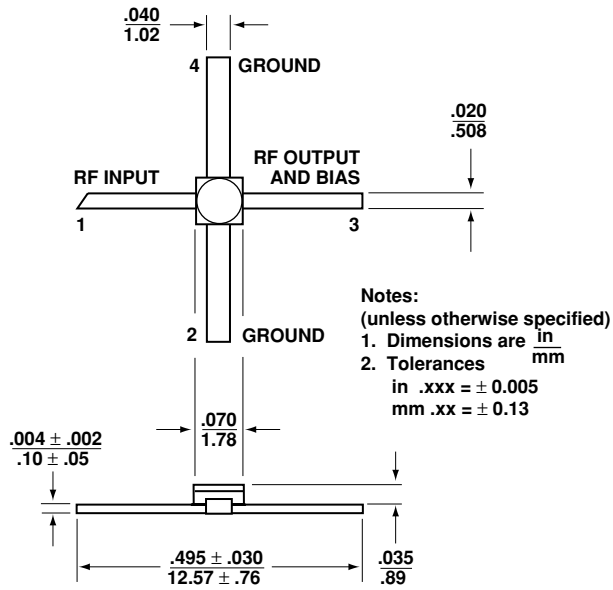

Figure 6. Noise Figure vs. Frequency.

Ordering Information

Part Numbers	No. of Devices	Comments
MSA-0770	100	Bulk

70 mil Package Dimensions



For product information and a complete list of distributors, please go to our web site: www.avagotech.com

Avago, Avago Technologies, and the A logo are trademarks of Avago Technologies, Limited in the United States and other countries. Data subject to change. Copyright © 2008 Avago Technologies, Limited. All rights reserved. Obsoletes 5989-2761EN AV02-1230EN - May 15, 2008

AVAGO
TECHNOLOGIES