

# AVAGO ASMT-CR00

AlInGaP Red

0.4mm Low Profile

Right Angle Surface Mount ChipLED

## Datasheet



### Description

The ASMT-CR00 of red color chip-type LEDs is designed with the smallest footprint to achieve high density of components on board. They have the industry standard footprint 1.6 mm x 1.0 mm and a height of only 0.4 mm. This makes them very suitable for cellular phone and mobile equipment backlighting and indication application where space is a constraint. In order to facilitate automated pick and place operation, these ChipLEDs are shipped in conductive tape and reel, with 4000 units per reel. These part are compatible with IR soldering.

### Features

- Small size right angle mount
- 0603 industry standard footprint
- 0.4 mm low profile type
- Operating temperature range of -40°C to +85 °C
- Compatible with IR reflow soldering process
- Available in 8mm tape on 178mm (7") diameter reels
- Reel sealed in zip locked moisture barrier bags

### Applications

- LCD Backlighting
- Keypad Side / Backlighting
- Pushbutton backlighting
- Symbol Indicator

### Package Dimension

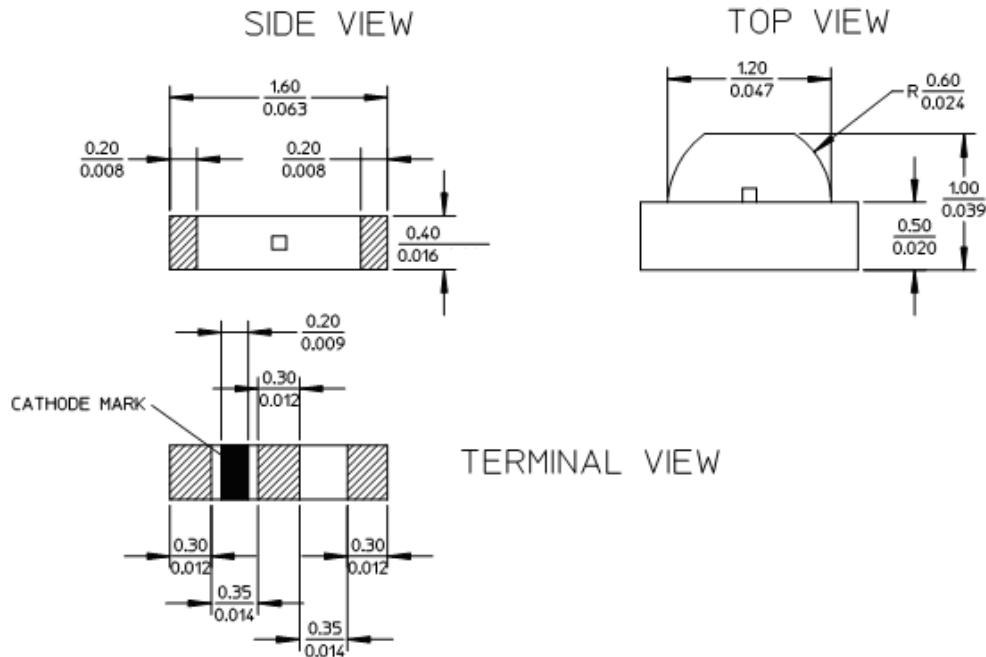

NOTES:  
1. ALL DIMENSIONS IN MILLIMETERS (INCHES).  
2. TOLERANCE IS  $\pm 0.1$  mm ( $\pm 0.004$  IN.) UNLESS OTHERWISE SPECIFIED.

### Device Selection Guide

Package Dimension (mm)	Parts per Reel	Package Description
1.6 (L) x 1.0 (W) x 0.4 (H)	4000	Untinted, Non-diffused

**CAUTION:** ASMT-CR00 LEDs are Class 1A ESD sensitive per JESD22-A114C.01. Please observe appropriate precautions during handling and processing. Refer to Application Note AN-1142 for additional details.

## Absolute Maximum Ratings at T<sub>A</sub> = 25°C

Parameter	ASMT-CR00	Unit
DC Forward Current <sup>[1]</sup>	25	mA
Power Dissipation	60	mW
Reverse Voltage (I <sub>R</sub> = 100μA)	5	V
LED Junction Temperature	95	°C
Operating Temperature Range	-40 to +85	°C
Storage Temperature Range	-40 to +85	°C
Soldering Temperature	See reflow soldering profile (Figure 6 & 7)	

### Note:

1. Derate linearly as shown in Figure 4.

## Electrical Characteristics at T<sub>A</sub> = 25°C

Part Number	Forward Voltage		Reverse Breakdown	Thermal Resistance
	V <sub>F</sub> (Volts) <sup>[1]</sup>		V <sub>R</sub> (Volts)	R <sub>θ</sub> J-PIN (°C/W)
	@ I <sub>F</sub> = 20mA		@ I <sub>R</sub> = 100μA	
	Typ.	Max.	Min.	Typ.
ASMT-CR00	1.9	2.4	5	400

### Notes:

1. V<sub>f</sub> tolerance : ±0.1V

## Optical Characteristics at T<sub>A</sub> = 25°C

Part Number	Luminous Intensity		Peak	Dominant	Viewing Angle
	I <sub>v</sub> <sup>[1]</sup> (mcd)		Wavelength	Wavelength	2 θ <sub>1/2</sub> <sup>[3]</sup>
	@ 20mA		λ <sub>peak</sub> (nm)	λ <sub>d</sub> <sup>[2]</sup> (nm)	(Degrees)
	Min.	Typ.	Typ.	Typ.	Typ.
ASMT-CR00	28.5	90.0	637.0	626.0	150

### Notes:

1. The luminous intensity I<sub>v</sub> is measured at the peak of the spatial radiation pattern which may not be aligned with the mechanical axis of the LED package.
2. The dominant wavelength, λ<sub>d</sub>, is derived from the CIE Chromaticity Diagram and represents the perceived color of the device.
3. θ<sub>1/2</sub> is the off-axis angle where the luminous intensity is ½ the peak intensity.

### Light Intensity (Iv) Bin Limits

Bin ID	Intensity (mcd)	
	Minimum	Minimum
N	28.50	45.00
P	45.00	71.50
Q	71.50	112.50
R	112.50	180.0

Tolerance :  $\pm 15\%$

#### Notes:

1. Bin categories are established for classification of products. Products may not be available in all categories. Please contact your Avago representative for information on current available bins.
2. The Iv binning specification set-up is for lowest allowable Iv binning only. There is no upper Iv bin limits.

### Color Bin Limits

Bin ID	Dominant Wavelength (nm)	
	Minimum	Maximum
-	620.0	635.0

Tolerance :  $\pm 1\text{nm}$

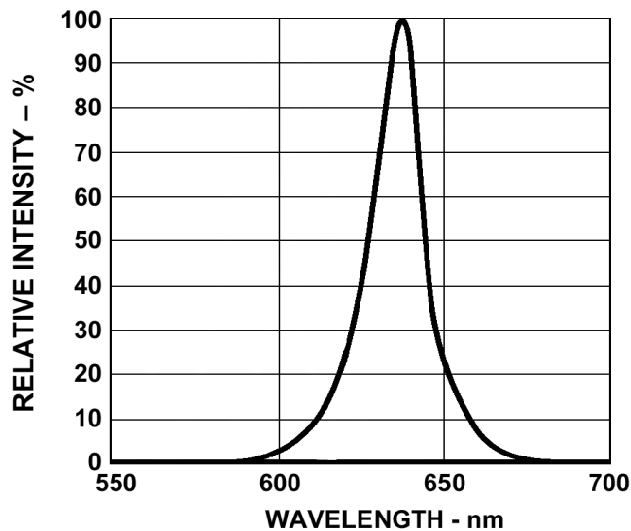

Figure 1. Relative intensity vs. wavelength

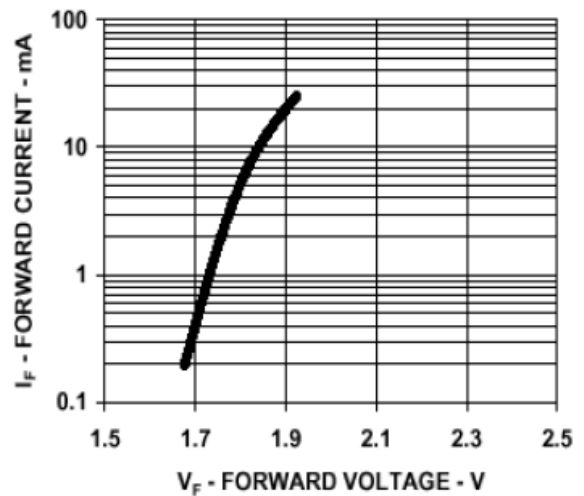

Figure 2. Forward current vs. forward voltage

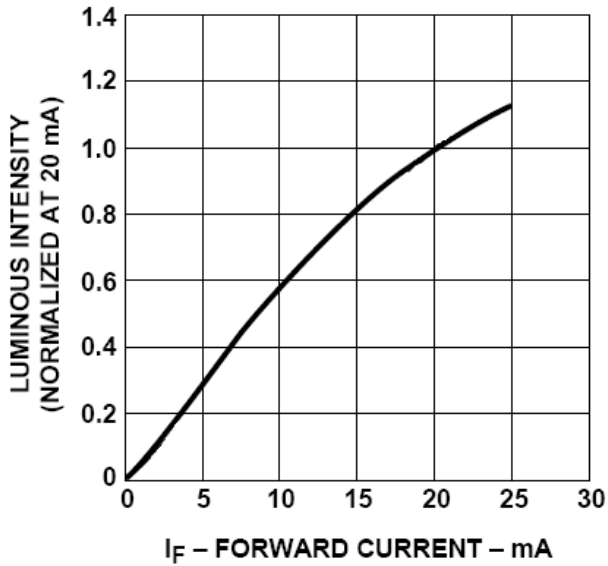

Figure 3. Luminous intensity vs. forward current

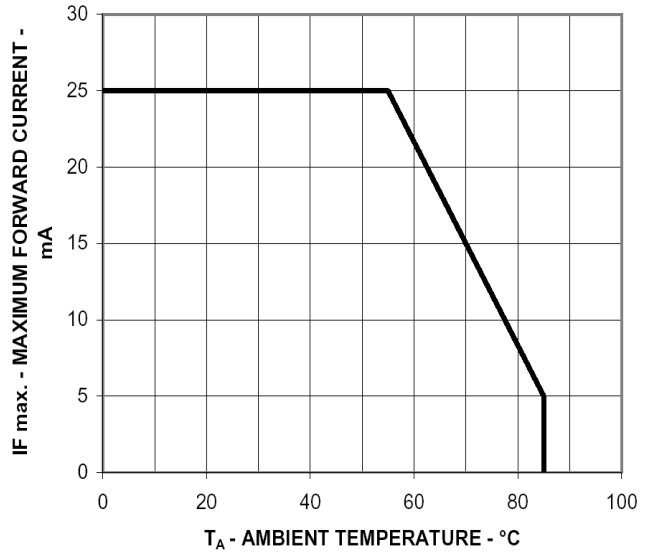

Figure 4. Maximum forward current vs. ambient temperature

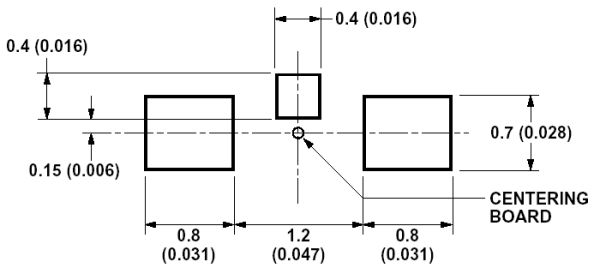
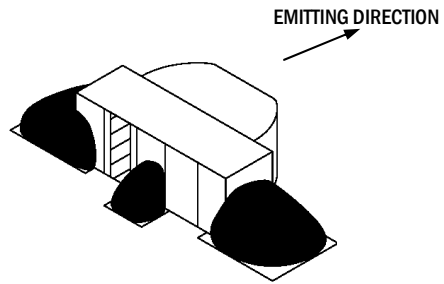

Figure 5. Recommended soldering land pattern.



**Notes:**

1. All dimensions are in millimeters (inches).
2. Tolerance is  $\pm 0.1\text{mm}$  ( $\pm 0.004\text{in.}$ ) unless otherwise specified.

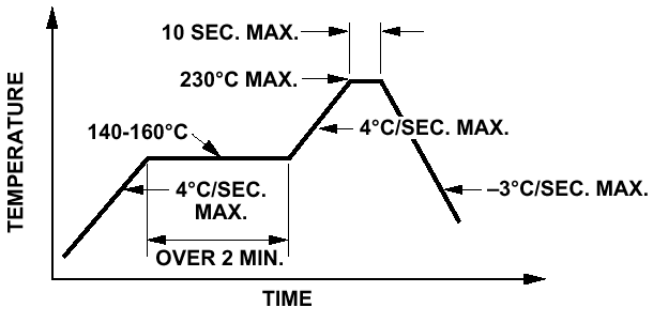

Figure 6. Recommended reflow soldering profile.

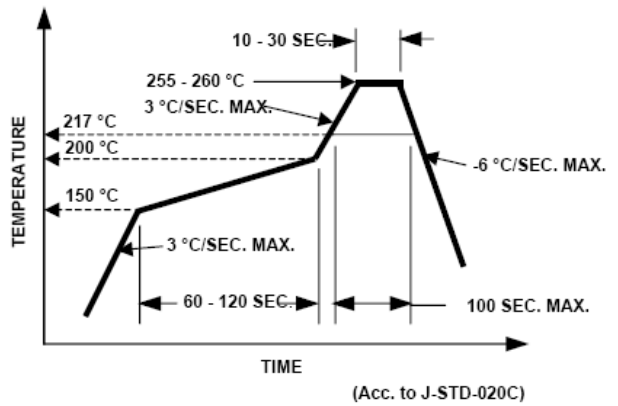

Figure 7. Recommended Pb-free reflow soldering profile.

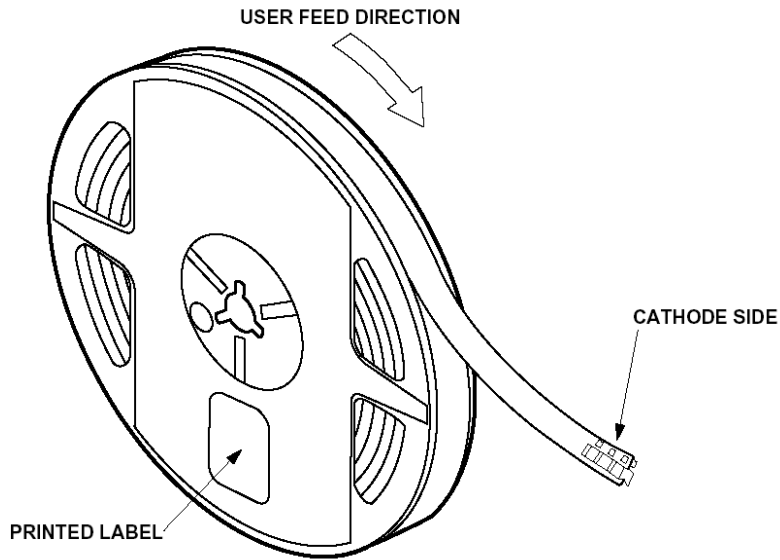

Figure 9. Reeling orientation.

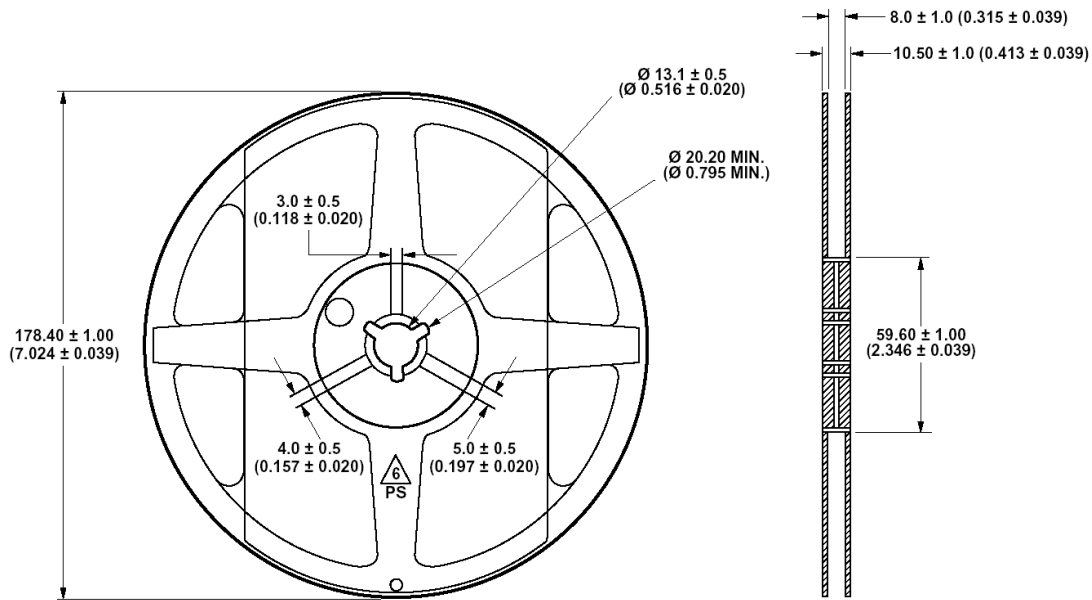
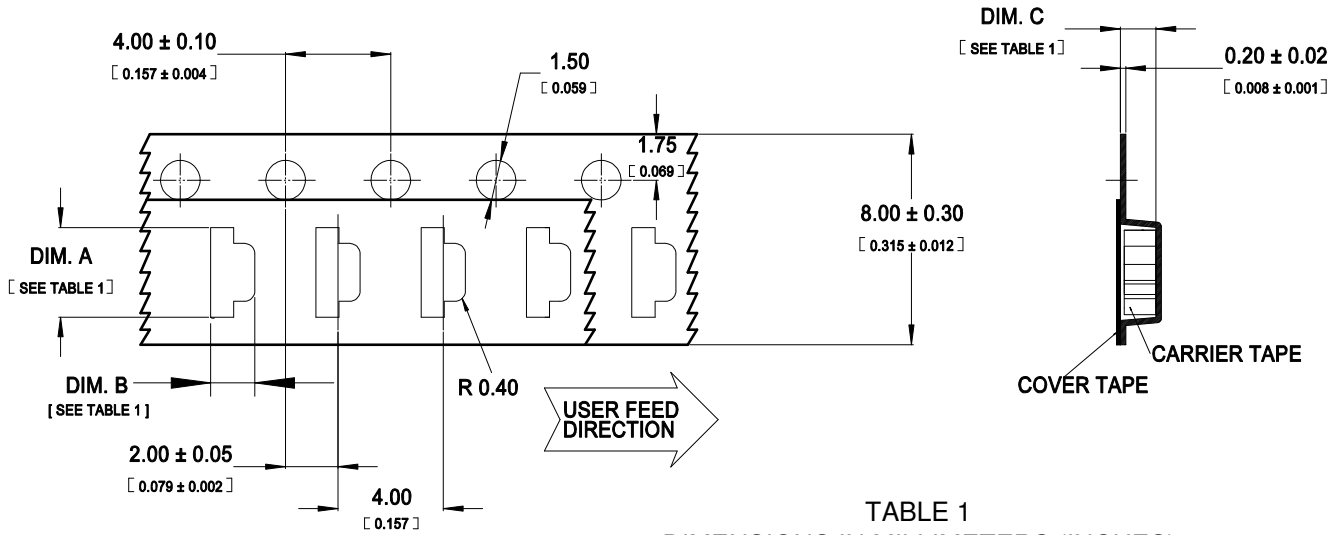

Figure 10. Reel dimensions.

**Notes:**

1. All dimensions are in millimeters (inches).
2. Tolerance is ±0.1mm (±0.004in.) unless otherwise specified.



**TABLE 1**  
**DIMENSIONS IN MILLIMETERS (INCHES)**

PART NUMBER	DIM.A ± 0.10 (0.004)	DIM.B ± 0.10 (0.004)	DIM.C ± 0.10 (0.004)
ASMT-CR00	1.75 (0.069)	1.10 (0.043)	0.60 (0.024)

**Figure 11. Tape dimensions.**

**Notes:**

1. All dimensions are in millimeters (inches).
2. Tolerance is ±0.1mm (±0.004in.) unless otherwise specified.

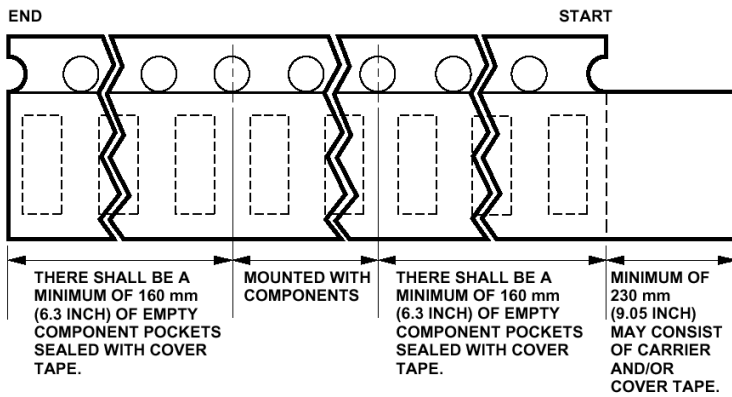

**Figure 12. Tape leader and trailer dimensions.**

**Reflow Soldering:**

For more information on reflow soldering, refer to Application Note AN-1060, *Surface Mounting SMT LED Indicator Components*.

**Storage Condition:**

5 to 30°C @ 60%RH max.

Baking is required before mounting, if:

1. Humidity Indicator Card is > 10% when read at 23 ± 5°C.
2. Device expose to factory conditions <30°C/60%RH more than 672 hours.

Recommended baking condition:

60±5°C for 20 hours.

**Handling Precaution**

Customer are advised to implement proper handling precaution as the thin package of 0.4mm will have high potential of crack epoxy during application. Stacking the PCBA is strictly prohibited.