



## INSTRUCTION MANUAL

Models: H100  
Light Meter



# Table of Content

<b>1. Product Introduction</b> .....	<b>3</b>
1-1 Features .....	3
1-2 Applications .....	3
<b>2. Safety Information</b> .....	<b>4</b>
2-1 Cautions .....	4
2-2 Safety Symbols .....	4
<b>3. Specifications</b> .....	<b>5</b>
<b>4. Operation Instructions</b> .....	<b>7</b>
4-1 Unit Diagram .....	7
4-2 Measuring Procedure .....	8
4-3 Zero Adjust .....	8
4-4 Data Hold .....	8
4-5 Peak Hold .....	8
4-6 Data Record .....	9
<b>5. Auto Power Off Disable</b> .....	<b>9</b>
<b>6. RS232 PC Serial Interface Information</b> .....	<b>10</b>
<b>7. Battery Replacement</b> .....	<b>11</b>
<b>8. Service Information</b> .....	<b>12</b>
<b>9. Warranty Information</b> .....	<b>13</b>

To see all available accessories and downloadable software, please visit  
[www.anaheimscientific.com](http://www.anaheimscientific.com)

# 1. Product Introduction

## 1-1 Features

- Two year warranty
- Large LCD display with bar graph
- Wide measurement ranges: 40.00/400.0/4,000/40,000/400,000lux
- Display resolution: 0.04lux to 100lux, 0.01ft-cd to 10ft-cd
- lux or foot-candle unit selection
- 4 light type select (Tungsten, Fluorescent, Sodium or Mercury)
- Sensor meet C.I.E. spectrum, 2 filters
- Data hold, Record (max., min.)
- DC 1.5V battery ( UM-4, AAA) x 6
- Longer battery life compared to 9V

## 1-2 Applications

- Science Experiments
- Photography
- Manufacturing
- Agriculture
- Artistry

## 2. Safety Information

Read the following safety information carefully before attempting to operate or service the meter. Only qualified personnel should perform repairs or servicing not covered in this manual.

### 2-1 Cautions!

- **DO NOT** submerge the products mentioned in this manual in water or any other types of liquids.
- This product is not designed for use in medical applications. The product can only be used to measure body temperature simply for reference.

### 2-2 Safety Symbols



Dangerous, refer to this manual before using the meter.



Conforms to requirements of European Union and European Free Trade Association (EFTA).



Battery level is low.



Don't dispose this product as unsorted municipal waste.

This instrument conforms to the following standards:

**EN61326:** Electrical equipment for measurement, control and laboratory use.

**IEC61000-4-2:** Electrostatic discharge immunity test.

**IEC61000-4-3:** Radiated, radio-frequency, electromagnetic field immunity test.

**IEC61000-4-8:** Power frequency magnetic field immunity test.

### 3. Specifications

Display	5 Digit LCD with bar graph indicator
Measurement Ranges	40.00/400.0/4,000/40,000/400,000lux
Unit of Measurement	lux or Foot-Candle (fc)
Measurable Lighting Sources	Tungsten, Fluorescent, Sodium or Mercury Lamps
Sensor	Photo diode & color correction filter, spectrum meets C.I.E. Cosine correction factor standards

Display values:

Unit	Range	In Range Display	Resolution
lux	40	0 to 40.00 Lux	0.01 Lux
	400	36.0 to 400.0 Lux	0.1 Lux
	4,000	360 to 4,000 Lux	1 Lux
	40,000	3,600 to 40,000 Lux	10 Lux
	400,000	10,000 to 400,000 Lux	100 Lux
fc (foot-candle)	4	0 to 3.720 Fc	0.001 Fc
	40	3.35 to 37.20 Fc	0.01 Fc
	400	33.5 to 372.0 Fc	0.1 Fc
	4,000	335 to 3,720 Fc	1 Fc
	40,000	930 to 37,200 Fc	10 Fc

Accuracies:

	Range	Accuracy**
lux	40	± ( 3% rdg + 0.5 % F.S. )
	400	
	4,000	
	40,000	
	400,000	
fc (foot-candle)	4	± ( 3% rdg + 0.5 % F.S. )
	40	
	400	
	4,000	
	40,000	

Zero Adjust	40.00lux range only
Peak Hold	Displays peak value
Data Hold	Display freeze
Memory	Saves MAX. or MIN values with recall
Power Off	Auto or manual control
Over and Under Range Indicator	Over range indicator: "----" (top of the display) Under range indicator: "----" (bottom of the display)

Data Output	RS-232 Serial data output
Operating Environment	32° to 122°F (0° to 50°C), <80% R.H.
Power Supply	6 Pieces of DC 1.5V Batteries (UM4, AAA or equivalent)
Weight (approx.)	0.79lbs. (357g)
Dimensions (approx.)	Main instrument: 6.9 x 2.7 x 1.7" (174 x 68 x 42mm)
	Sensor probe: 3.5 x 2.4 x 0.8" (89 x 61 x 20mm)
Included Accessories	Instruction manual, battery, carrying case

\* = Accuracies for lux over 100,000 and fc over 9,300 are not specified.  
 Readings are for reference only.

\*\* = Note : Accuracy tested by a standard parallel light tungsten lamp of  
 2856 K degree temperature.

Specifications and information are subject to change without notice  
 Please visit [www.anaheimscientific.com](http://www.anaheimscientific.com) for the most current product information.

### Spectrum for Light Sensor

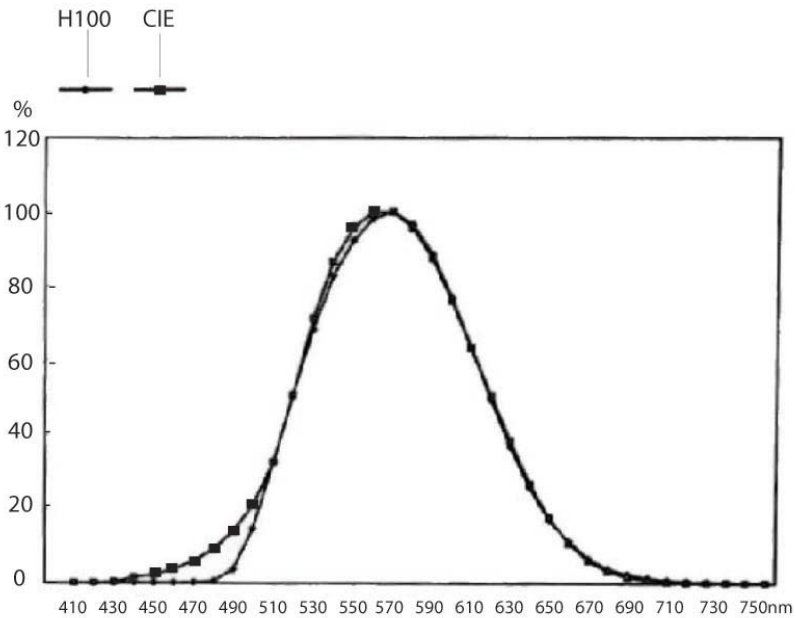

## 4. Operating Instructions

### 4-1 Unit Diagram

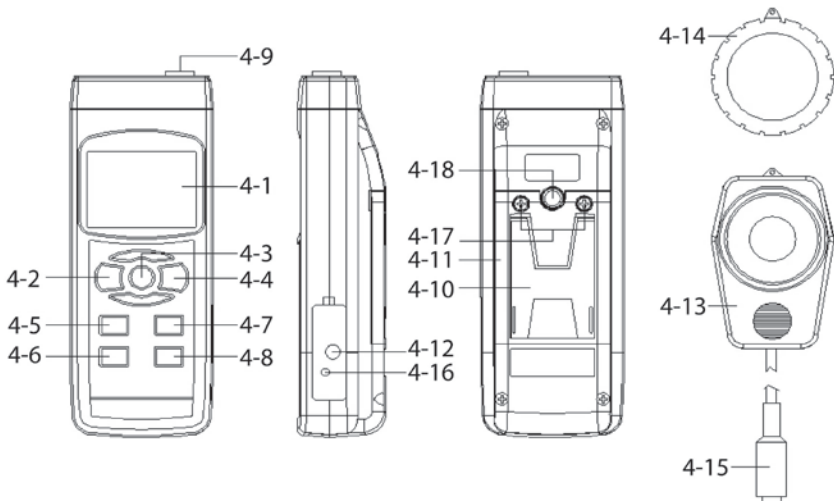

Fig. 1

- 4-1 Display
- 4-2 Power Button
- 4-3 Hold Button
- 4-4 REC (MAX/MIN) Button
- 4-5 Lux/Fc Button
- 4-6 Range Button
- 4-7 Zero Button
- 4-8 Light Source Button
- 4-9 Light Sensor Input Socket



- 4-10 Stand
- 4-11 Battery Compartment
- 4-12 RS232 Socket
- 4-13 Light Sensor
- 4-14 Sensor Protective Cover
- 4-15 Light Sensor Plug
- 4-16 LCD Display Contrast Adjust
- 4-17 Battery Cover Screw
- 4-18 Tripod Screw Mount



## 4-2 Measuring Procedure

1. Push the "Power Button" (4-2, Fig. 1) to power on the instrument. The meter will perform a short self-test before measurements can be taken.
2. Select the desired unit of measurement by pressing the "Lux/Fc Button" (4-5, Fig. 1). The display will indicate the selected unit of "Lux" or "Ft-cd".
3. Determine the lighting type (Tungsten, Fluorescent, Sodium or Mercury lamp) by pressing the "Light Source Select Button" (4-8, Fig. 1). For unknown light types we recommend you use Tungsten

Note: The LCD display will indicate the selected lighting type with the following symbols:

<i>Tungsten :</i>  No symbol	<i>Fluorescent :</i> 
<i>Mercury :</i> 	<i>Sodium :</i> 

4. Select the max range by using the "Range Button" (4-6, Fig. 1)
  - a. If the main display shows "----", it indicates overload condition. Select the next higher range.
  - b. If the main display shows " \_ \_ \_ \_ ", it indicates out-of-range. Select the next lower range.
  - c. To get the most accuracy from this unit, use the range that will both display the measured value with the highest resolution.
5. Position the "Light Sensor" (4-13, Fig. 1) directly under the light source.

## 4-3 Zero Adjust

- a. Cover the "Light Sensor" (4-13, Fig. 1) using the "Sensor Cover" (4-14, Fig. 1). **Do not** remove the "Sensor Cover".
- b. Set to 40.00 Lux range. (other ranges need not be zeroed)
- c. Pushing the "Zero Button" (4-7, Fig. 1) will zero out the LCD display.
- d. Upon completion, remove the sensor cover.

## 4-4 Data Hold

- a. During measurements, press the "Hold Button" (4-3, Fig. 1). The data on the LCD display will be held and the "HOLD" symbol will be displayed.
- b. Push the "Hold Button" again to release the data hold function and return the display to show current readings.

## 4-5 Peak Hold

- a. During a measurement press and hold the "Hold Button" (4-3, Fig. 1) for at least 3 seconds. The meter will now only display and hold the largest measured value along with the "Peak HOLD" indicator.
- b. To clear the peak value momentarily press the "Hold Button" (4-3, Fig. 1).
- c. To turn off the Peak Hold function, press and hold the "Hold Button" (4-3, Fig. 1) for at least 3 seconds.

#### **4-6 Data Record**

- a. The data record function records the maximum and minimum readings. Press the "REC Button" (4-4, Fig. 1) to start the data record function.
- b. With the "REC" symbol on the display momentarily pressing the "REC Button" (4-4, Fig. 1) will toggle between Max and Min recording.
- c. To exit the memory record function, press and hold the "REC Button" (4-4, Fig. 1) for at least 3 seconds.
- d. Note: To delete the displayed value while recording, just press the "Hold Button" (4-3, Fig. 1) until the display clears the data leaving the "REC" symbol.

#### **5. Auto Power Off Disable**

This instrument has a "Auto Power Off " function that can prolong battery life. The meter will shut off automatically if none of the buttons are pressed in approx. 10 min.

To disable this function, select the memory record function during a measurement by pressing the " REC. Button" (4-4, Fig. 1 ).

## 6. RS232 PC Serial Interface Information

This instrument has RS232 PC serial interface via a 3.5 mm terminal (4-12, Fig. 1).

The data output is a 16 digit stream which can be utilized for user's specific application.

A RS232 lead with the following connection will be required to link the instrument with the PC serial port.

Visit [www.anaheimscientific.com](http://www.anaheimscientific.com) to see any available downloadable software for your instrument.

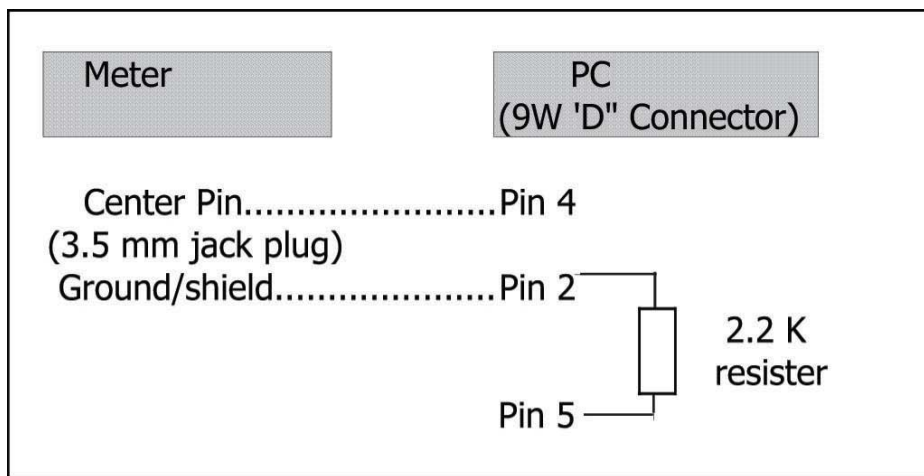

The 16 digit data stream will be displayed in the following format:

D15 D14 D13 D12 D11 D10 D9 D8 D7 D6 D5 D4 D3 D2 D1D0

Each digit indicates the following status:

D15	Start Word	
D14	4	
D13	When send the upper display data = 1 When send the lower display data = 2	
D12 & D11	Indicator for Display	
	Lux = 15	Fc = 16
D10	Polarity: 0 = Positive / 1 = Negative	
D9	Decimal Point (DP), position from right to left 0 = No DP, 1 = 1 DP, 2 = 2 DP, 3 = 3 DP	
D8 to D1	Display reading, D1 = LSD, D8 = MSD Example: If the display reading is 1234, then D8 to D1 is: 00001234	
D0	End Word	

### RS232 Setting

Baud Rate	9600
Parity	No Parity
Data bit #	8 Data bits
Stop bit	1 Stop bit

## 7. Battery Replacement

1. When the LCD display shows the  low battery symbol, It is necessary to replace the battery. The specifications listed for this instrument do not apply when the low battery symbol is displayed.
2. Open the "Battery Compartment" (4-11, Fig. 1) by first loosening the "Battery Cover Screws" (4-17, Fig. 1).
3. Replace the batteries with "good" batteries noting the correct polarity. Replace "Battery Compartment" (4-11, Fig. 1) and "Battery Cover Screws" (4-17, Fig. 1). Ensure the cover is securely fastened.

## 8. Service Information

**Warranty Service:** Please return the product in the original packaging with proof of purchase to the address below. Clearly state in writing the performance problem and return any leads, probes, connectors and accessories that you are using with the device.

**Non-Warranty Service:** Return the product in the original packaging to the address below. Clearly state in writing the performance problem and return any leads, probes, connectors and accessories that you are using with the device. Customers not on open account must include payment in the form of a money order or credit card. For the most current repair charges please visit [www.anaheimscientific.com](http://www.anaheimscientific.com) and click on “service/repair”.

Return all merchandise to Anaheim Scientific with pre-paid shipping. The flat-rate repair charge for Non-Warranty Service **does not** include return shipping. Return shipping to locations in North American is included for Warranty Service only. For overnight shipments and non-North American shipping fees please contact Anaheim Scientific.

Anaheim Scientific  
22820 Savi Ranch Parkway  
Yorba Linda, CA 92887  
[www.anaheimscientific.com](http://www.anaheimscientific.com)  
714-921-9095

**Include with the returned instrument your complete return shipping address, contact name, phone number and description of problem.**

## 9. Limited Two-Year Warranty

Anaheim Scientific warrants to the original purchaser that its products and the component parts thereof, will be free from defects in workmanship and materials for a period of two years from date of purchase from an authorized Anaheim Scientific distributor.

Anaheim Scientific will, without charge, repair or replace, at its option, defective product or component parts. Returned product must be accompanied by proof of the purchase date in the form of a sales receipt.

To obtain warranty coverage in the U.S.A., this product must be registered by completing the warranty registration form on [www.anaheimscientific.com](http://www.anaheimscientific.com) within fifteen (15) days of purchase.

**Exclusions: This warranty does not apply in the event of misuse or abuse of the product or as a result of unauthorized alterations or repairs. The warranty is void if the serial number is altered, defaced or removed.**

Anaheim Scientific shall not be liable for any consequential damages, including without limitation damages resulting from loss of use. Some states do not allow limitations of incidental or consequential damages. So the above limitation or exclusion may not apply to you.

This warranty gives you specific rights and you may have other rights, which vary from state-to-state.

Anaheim Scientific  
22820 Savi Ranch Parkway  
Yorba Linda, CA 92887  
[www.anaheimscientific.com](http://www.anaheimscientific.com)  
714-921-9095



**Anaheim Scientific**

22820 Savi Ranch Parkway  
Yorba Linda, CA 92887  
U.S.A.  
[www.anaheimscientific.com](http://www.anaheimscientific.com)