

# EKI-6310GN

IEEE 802.11 b/g/n Wi-Fi AP / CPE



## Features

- Compliant with IEEE802.11b/g/n
- IP66 waterproof certification
- High output power 27dBm
- Standard PoE (802.3af) support
- Support distances up to 5Km
- Support wireless data encryption with 64/128 bits WEP/WPA/WPA2/TKIP with IEEE 802.1X-Enterprise encryption for a highly secure wireless network
- WEP/WPA/WPA2/ IEEE 802.1x authentication support
- Support WPS by software

## Introduction

The EKI-6310GN is a feature rich wireless AP/ CPE which provides a reliable wireless connectivity for industrial environments. The standard PoE input enhances flexibility in deployment of this AP/ CPE even where the DC power supply is hard to fulfill. As an 802.11n compliant device, EKI-6310GN provides 3 times higher data rates than legacy 802.11g devices. EKI-6310GN, with an integrated Type N RF connector that can be directly plugged in to any antenna to create a robust outdoor AP/CPE, effectively improves the reliability of wireless connectivity, especially in applications that need high reliability and high throughput data transmission. To secure wireless connections, EKI-6310GN implements the latest encryption technologies including WEP/WPA/WPA2/802.1x for powerful security authentication.

## Specifications

### Standard Support

- **Wireless** IEEE802.11b/g/n
- **Ethernet** IEEE802.3u MDI / MDIX 10/100 Fast Ethernet
- **LAN** IEEE802.11b/g wireless LAN interface IEEE 802.11n wireless LAN standard Standard PoE 802.3af
- **Data Rates** 802.11b 11, 5.5, 2, 1 Mbps, auto-fallback, 802.11g 54, 48, 36, 24, 18, 12, 9, 6 Mbps, auto-fallback
- **802.11n** 6M, 6.5M, 13M, 13.5M, 19.5M, 26M, 27M, 39M, 40.5M, 53M, 54M, 58.5M, 65M, 78M, 81M, 104M, 108M, 117M, 121.5M, 130M, 135M, 150Mbps

### Physical Specifications

- **Power** Standard PoE 802.3af
- **Dimensions (W x H x D)** 61.7 x 206.2 x 47.7 mm (2.43" x 8.12" x 1.88")
- **Mounting** DIN-rail, Wall, Pole
- **Weight** 0.5 Kg

### Environment

- **Operating Temp.** Non Heater: -30 ~ 70°C (-22 ~ 158°F)
- **Storage Temperature** -30 ~ 80°C (-22 ~ 176°F)
- **Humidity** 10% ~ 95% non-condensing

### Interface Operation Modes

- Access Point (AP) / Customer Premise Equipment (CPE)

### Antenna

- **Antenna Configuration** 1x1 ( 1 Tx, 1 Rx)
- Reserve N-type Connector (Plug)

\*Equipped N-to-RSMA adaptor and 5dBi dipole antenna for indoor AP applications.

### Other Features

- Telnet, FTP, SNMP, Password Changes, Firmware updates, Configuration Files
- Output Power Control, Bandwidth Control, Distance Adjustment, Site survey
- Open System , Shared Key, Radius 802.1X , WPA, WPA2, WPA-PSK (TKIP)

### Modulation Techniques

- **802.11n** OFDM(BPSK, QPSK, 16-QAM, 64-QAM)
- **802.11b** DSSS (DBPSK, DQPSK, CCK)
- **802.11g** OFDM (BPSK, QPSK, 16-QAM, 64-QAM)

### Channel Support

- **802.11b/g/n** HT20  
FCC: CH1 ~ CH11; ETSI: CH1 ~ CH13
- **802.11gn** HT40  
FCC: CH3 ~ CH9; ETSI: CH3 ~ CH11

### Wireless Transmission Rates

- **Transmitted Power** Max. 27 dBm

### Receiver Sensitivity

- **802.11b Sensitivity** -95dBm @ 11Mbps
- **802.11g Sensitivity** -92dBm @ 54Mbps
- **802.11n Sensitivity** -90dBm @ HT20

## Dimensions

Unit: [mm]

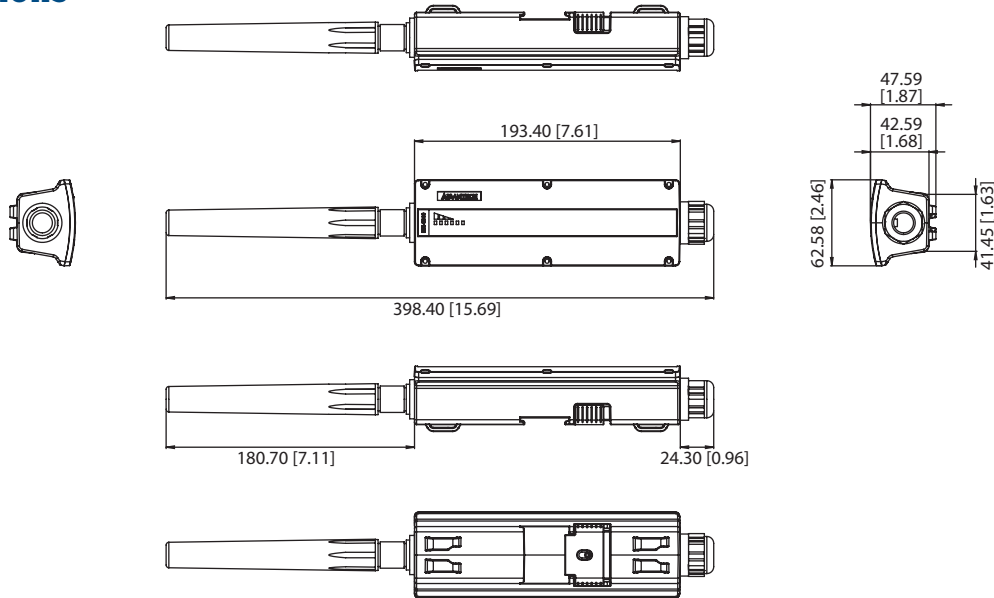

**Panel Cut-out Dimensions: 398.4 x 62.58 x 47.59 mm (15.69" x 2.46" x 1.87")**

## Ordering Information

- EKI-6310GN 802.11 b/g/n Wireless Access Point/CPE (US)
- EKI-6310GN-EU 802.11 b/g/n Wireless Access Point/CPE (EU)