

# NovaHood™ Connector Covers

## The Ultimate in Versatility

The NovaHood can be used for any style connector.... crimp-snap, solder and insulation displacement. A connector can be fitted in one or both ends. Cables may be routed from either side or end. Hoods are available for DB-9, DB-15 and DB-25 connectors.



NovaHoods-clockwise from top left: black DB-25, Metalized DB-25, black DB-9, black DB-15

## Simplified Assembly and Inventory

The NovaHood is designed for maximum productivity in cable and interface adapter production while maintaining consistent high quality and low cost. The snap-lock case minimizes assembly time. No screws are required to hold the case together. And the two interlocking shells for each size are identical, simplifying inventory.



## The Economy of PLASTIC with the Quality and Security of METAL

The standard NovaHood is rugged ABS plastic. If you need to meet FCC computer emissions restrictions, Tempest requirements or other applications requiring shielding, the 25-pin NovaHood can be purchased with an optional conductive metal plating to help achieve that goal.

## Gender-Menders and More

In addition to use as a connector backshell, NovaHood can also be used to build gender changers, converters or anything else that requires two D-subminiature connectors. It can be used to build loop-back test plugs or jumper plugs in modem eliminators. Because of its sturdy, integrated design, the cable or system integrity is not compromised by these applications.

## NovaHoods "Your Way"

NovaHoods may be purchased in bulk or in kits. Bulk prices are for two hood halves and a strain relief. Kits contain two hood halves, a strain relief, tie wrap and two 4-40 screws and saddle washers in a plastic bag. Standard color is black. Custom colors or metalizing on other sizes are available on quantity orders. Inquire about NovaHoods to suit your special needs, and for specific quantity order prices. Min. order: 20 pcs.

Part Number	Configuration	Description	Color	PRICES*			In stock at	
							B&B USA	B&B Europe
BP0925AK3011	DB-25/DB-9	Adapter - Kit	Gray				Yes	Yes
BP25AB0020	DB-25	Hood - Bulk	Black				Yes	Yes
BP25AK0020	DB-25	Hood - Kit	Black				Yes	Yes
BP25DK0010	DB-25	Double-length Hood - Kit	Black				Yes	Yes
BP25AB0030	DB-25	Hood - Bulk	Metalized				Yes	Yes
SR25AB0030	DB-25	Strain Relief	Metalized				Yes	Yes
BP15AB0010	DB-15	Hood - Bulk	Black				Yes	Yes
BP15AK0010	DB-15	Hood - Kit	Black				Yes	Yes
BP09AB0010	DB-9	Hood - Bulk	Black				Yes	Yes
BP09AB0030	DB-9	Hood - Bulk	Metalized				Yes	Yes
BP09AK0010	DB-9	Hood - Kit	Black				Yes	Yes

See page 2 for product drawings.

\*Intermediate and extended quantity price breaks available. Inquire.

© B&B Electronics – Revised January 2002

This product designed and manufactured in USA of domestic and imported parts by

**B & B Electronics Mfg. Co.**

707 Dayton Road - P.O. Box 1040 - Ottawa, IL 61350 USA

Phone: (815) 433-5100 - Fax: (815) 433-5105

Home Page: [www.bb-elec.com](http://www.bb-elec.com)

Sales e-mail: [orders@bb-elec.com](mailto:orders@bb-elec.com) - Fax: (815) 433-5109

Technical Support e-mail: [support@bb-elec.com](mailto:support@bb-elec.com) - Fax: (815) 433-5104

**B & B Electronics Ltd**

Westlink Commercial Park - Oranmore, Co. Galway - Ireland

Phone: +353 91 792444 - Fax: +353 91 792445

Home Page: [www.bb-europe.com](http://www.bb-europe.com)

Sales e-mail: [orders@bb-europe.com](mailto:orders@bb-europe.com)

Technical Support e-mail: [support@bb-europe.com](mailto:support@bb-europe.com)

# NovaHood™ Connector Covers

From B&B Electronics Manufacturing Co.

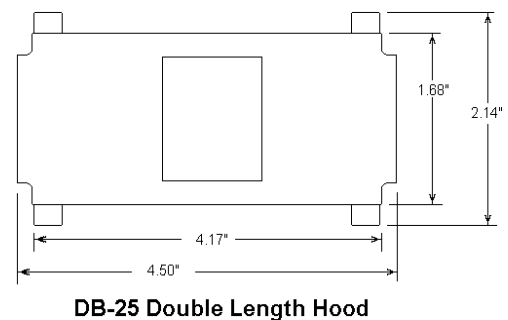
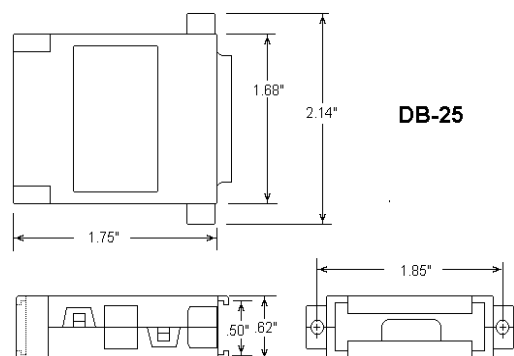
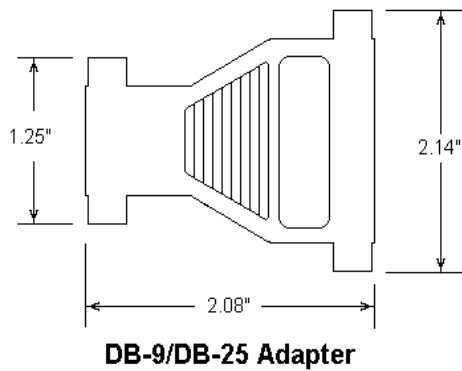
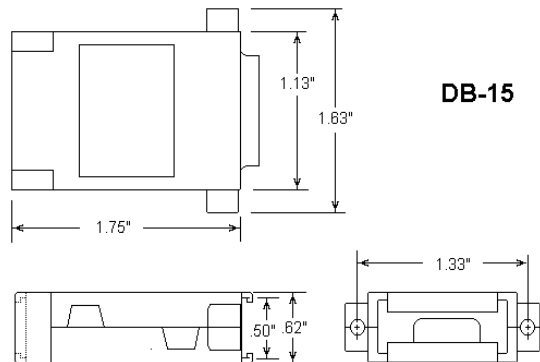
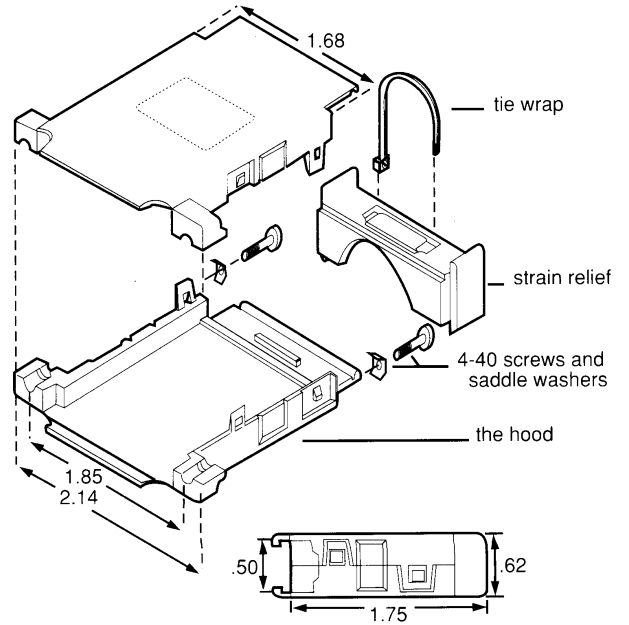
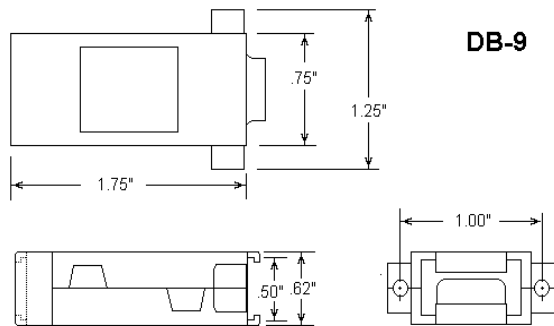

© B&B Electronics – Revised January 2002

*This product designed and manufactured in USA of domestic and imported parts by*

**B & B Electronics Mfg. Co.**

707 Dayton Road - P.O. Box 1040 - Ottawa, IL 61350 USA

Phone: (815) 433-5100 - Fax: (815) 433-5105

Home Page: [www.bb-elec.com](http://www.bb-elec.com)

Sales e-mail: [orders@bb-elec.com](mailto:orders@bb-elec.com) - Fax: (815) 433-5109

Technical Support e-mail: [support@bb-elec.com](mailto:support@bb-elec.com) - Fax: (815) 433-5104

**B & B Electronics Ltd**

Westlink Commercial Park - Oranmore, Co. Galway - Ireland

Phone: +353 91 792444 - Fax: +353 91 792445

Home Page: [www.bb-europe.com](http://www.bb-europe.com)

Sales e-mail: [orders@bb-europe.com](mailto:orders@bb-europe.com)

Technical Support e-mail: [support@bb-europe.com](mailto:support@bb-europe.com)