

AGQ300-48S1V2 DC/DC Converter

Technical Reference Notes

Industry standard quarter brick: 36V~75V input, 1.2V single output

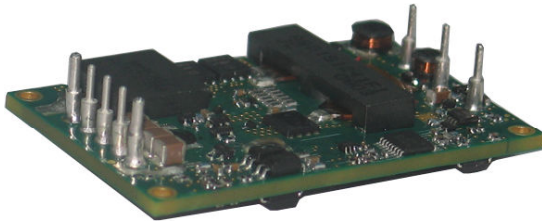

Industry standard quarter brick (open-frame)
2.28" × 1.45" × 0.4" (open-frame)
2.28" × 1.45" × 0.5" (with baseplate)

Options

- Choice of positive logic or negative logic for CNT function
- Choice of short pins or long pins

Description

AGQ300-48S1V2 is a new open-frame DC/DC converter for optimum efficiency and power density. AGQ300-48S1V2 is an industry standard quarter brick, which makes it an ideal choice for small space, high current and low voltage applications. The package size is 57.9mm × 36.8mm × 10.1mm (2.28" × 1.45" × 0.4") for open-frame and 57.9mm × 36.8mm × 12.7mm (2.28" × 1.45" × 0.5") with baseplate, and standard pinout configuration provides CNT and trim functions. AGQ300-48S1V2 can provide 1.2@60A single output that is isolated from inputs. The module can achieve ultra high efficiency, for most applications a heatsink is not required.

Features

- Industry standard quarter brick
- Basic isolation
- Ultra high efficiency
- Improved thermal performance
- High power density
- Low output noise
- Industry standard pinout
- 2:1 wide input voltage of 36V~75V
- CNT function
- Remote sense
- Trim function
- Over-temperature protection
- Output over-current protection (hiccup)
- Output over-voltage protection (hiccup)
- RoHS compliant

Module Numbering

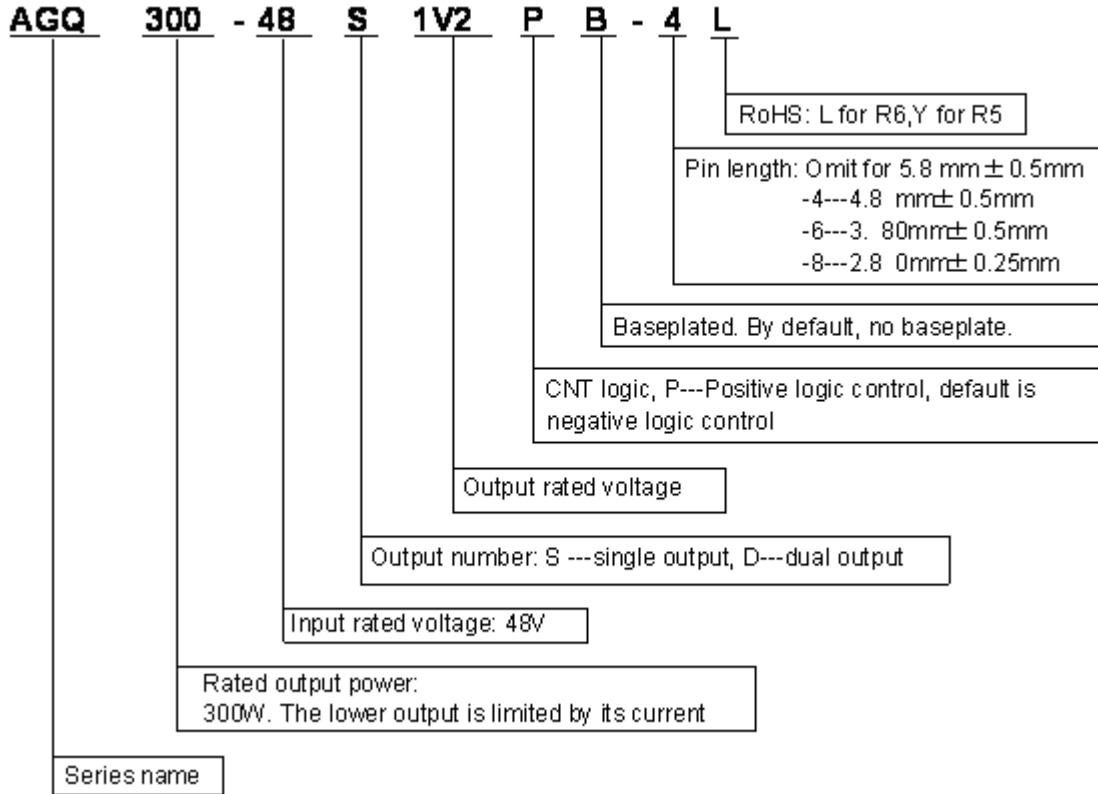

Electrical Specifications

Unless otherwise indicated, specifications apply over all operating input voltage and temperature conditions. Standard test condition on a single unit is as follows:

| | |
|---------------------------|---|
| T _c (board): | 25°C |
| +V _{in} : | 48V±2% |
| -V _{in} : | Return pin for +V _{in} |
| CNT: | Connect to -V _{in} for negative logic Open for positive logic |
| +V _{out} : | Connect to load |
| -V _{out} : | Connect to load (return) |
| +Sense: | Connect to +V _{out} |
| -Sense: | Connect to -V _{out} |
| Trim (V _{adj}): | Open |

Input Specifications

| Parameter | Symbol | Min | Typ | Max | Unit |
|--|--------------------|-----|-----|-----|-------|
| Operating input voltage | V _I | 36 | 48 | 75 | Vdc |
| Maximum input current (V _I =0 to V _{I,max} , I _o =I _{o,max}) | I _{I,max} | - | - | 2.5 | A |
| Input reflected-ripple current (rated input and output) | I _r | - | 10 | 20 | mAp-p |
| Supply voltage rejection (120Hz) | - | 50 | 60 | - | dB |

CAUTION: This power module is not internally fused. An input line fuse must always be used.

Absolute Maximum Ratings

Stresses in excess of the absolute maximum ratings can cause permanent damage to the device. These are absolute stress ratings only. Functional operation of the device is not implied at these or any other conditions in excess of those given in the operational sections of the IPS. Exposure to absolute maximum ratings for extended periods can adversely affect device reliability.

| Parameter | | Symbol | Min | Typ | Max | Unit |
|---|-------------------|----------------|-----|-----|------|--------------------|
| Input voltage | Continuous | V_I | - | - | 80 | Vdc |
| | Transient (100ms) | $V_{I, trans}$ | - | - | 100 | Vdc |
| Operating ambient temperature (See <i>Thermal Consideration</i>) | | T_a | -40 | - | 85 | °C |
| Operating board temperature | | T_c | - | - | - | °C |
| Storage temperature | | T_{STG} | -55 | - | 125 | °C |
| Operating humidity | | - | 5 | - | 95 | RH% |
| Basic input-output isolation | | - | | | 2000 | Vdc |
| Output power | | $P_{o,max}$ | - | - | 72 | W |
| Output ripple & noise (T_a : 25°C, air velocity: 200LFM, V_{in} : 48V, $V_{o,nom}$, $I_{o,nom}$, 10 μ tantalum (ESR \leq 100m Ω)/1 μ ceramic capacitor) | | - | - | - | 100 | mVp-p (f<20MHz) |
| Output ripple & noise (whole range) | | - | - | | 100 | mVp-p (f<20MHz) |

Output Specifications

| Parameter | | Symbol | Min | Typ | Max | Unit |
|--|-----------------------------|--------------------|------|-----|-------|------------------------|
| External load capacitance | | - | 470 | - | 30000 | μF |
| Output voltage setpoint ($V_I=V_{I,\text{min}}$ to $V_{I,\text{max}}$; $I_o=I_{o,\text{max}}$; $T_a=25^\circ\text{C}$) | | $V_{o,\text{set}}$ | 1.18 | 1.2 | 1.22 | Vdc |
| Output regulation | Line | - | - | 3 | 5 | mV |
| | Load | - | - | 5 | 10 | mV |
| | Temperature (whole range) | - | - | - | 0.02 | $\%V_o/^\circ\text{C}$ |
| Rated output current | | I_o | 0 | - | 60 | A |
| Output current-limit inception (hiccup) | | I_o | 66 | - | 84 | A |
| Over temperature protection (auto-recovery) | Board (for open-frame) | - | 110 | 120 | 135 | $^\circ\text{C}$ |
| | Hysteresis (for open-frame) | - | 5 | - | - | $^\circ\text{C}$ |
| Efficiency ($V_I=V_{I,\text{nom}}$; $I_o=I_{o,\text{max}}$; $T_a=25^\circ\text{C}$) | | - | - | 85 | - | % |

Output Specifications (Cont)

| Parameter | | Symbol | Min | Typ | Max | Unit |
|---|---|--------|-----|-----|-----------|---------------------|
| Dynamic response: ($V_I=V_{I,\text{nom}}$; $T_a=25^\circ\text{C}$; additional 470 μF load capacitor) | 25% $I_{o,\text{nom}}$ step from 50% $I_{o,\text{nom}}$, 0.1A/ μs | - | - | - | 90 400 | mV μs |
| | 75% $I_{o,\text{nom}}$ step from 50% $I_{o,\text{nom}}$, 0.1A/ μs | - | - | - | 140 | mV |
| | 10% $I_{o,\text{nom}}$ to 100% $I_{o,\text{nom}}$, 0.1A/ μs | - | - | - | 200 | mV |
| Turn-on time ($I_o=I_{o,\text{max}}$; V_o within 1%) | | - | - | 10 | 20 | ms |
| Output voltage overshoot ($I_o=I_{o,\text{max}}$; $T_a=25^\circ\text{C}$) | | - | - | - | 5 | $\%V_o$ |
| Switching frequency | | - | | 300 | | kHz |

Feature Specifications

| Parameter | | Symbol | Min | Typ | Max | Unit |
|---|---------------------------------------|---|------|---------|-----|-----------------|
| Enable pin voltage | Logic low | - | -0.7 | - | 1.2 | V |
| | Logic high | - | 3.5 | - | 12 | V |
| Enable pin current | Logic low | - | - | - | 1.0 | mA |
| | Logic high (leakage current, @10v) | - | - | - | - | μA |
| Output voltage trim range | | - | 80 | - | 110 | %V _o |
| Isolation capacitance | | - | - | - | - | PF |
| Isolation resistance | | - | 10 | - | - | MΩ |
| Calculated MTBF (V _{in} : 48V, load: I _{o,nom} , board@25°C) | | - | - | 2000000 | - | Hours |
| Weight (open-frame) | | - | - | 28 | - | g(oz.) |
| Vibration (sine wave) | | Vibration level: 3.5mm (2Hz ~ 9Hz), 10m/s ² (9Hz ~ 200Hz), 15m/s ² (200Hz ~ 500Hz) Directions and time: 3 axes (X, Y, Z), 30min each Sweep velocity: 1oct/min | | | | |
| Shock (half-sine wave) | | Peak acceleration: 300m/s ² Duration time: 6ms Continuous shock 3 times at each of 6 directions (±X, ±Y, ±Z) | | | | |

Characteristic Curves

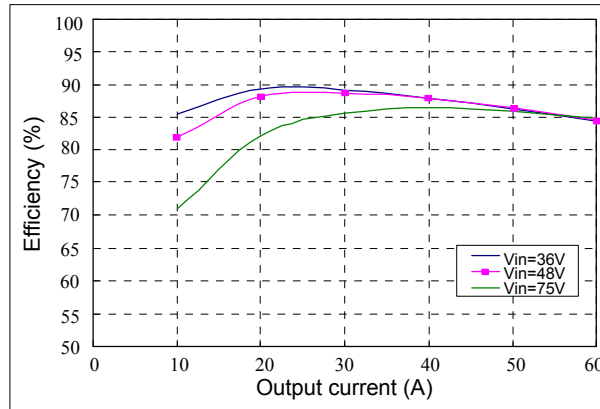

Figure 1 AGQ300 typical efficiency

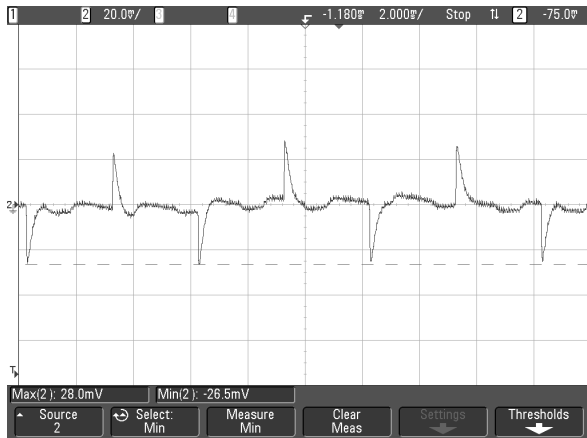

Figure 2 AGQ300 transient response to step in load from 25%~50%~25% ($\Delta I_o/\Delta t = 0.1A/1\mu s$)



Figure 3 AGQ300 transient response to step in load from 10%~100%~10% ($\Delta I_o/\Delta t = 0.1A/1\mu s$)

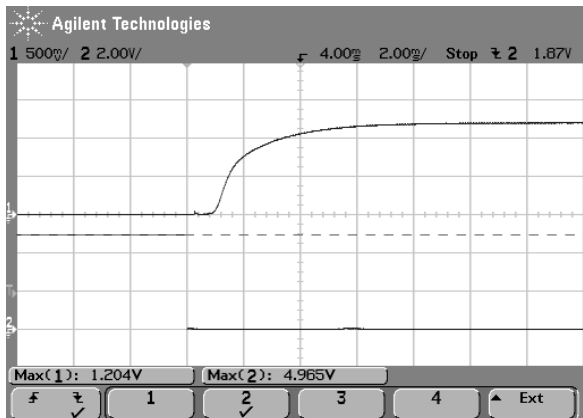

Figure 4 AGQ300 typical start-up from power on
ch1=Vout, ch2=CNT

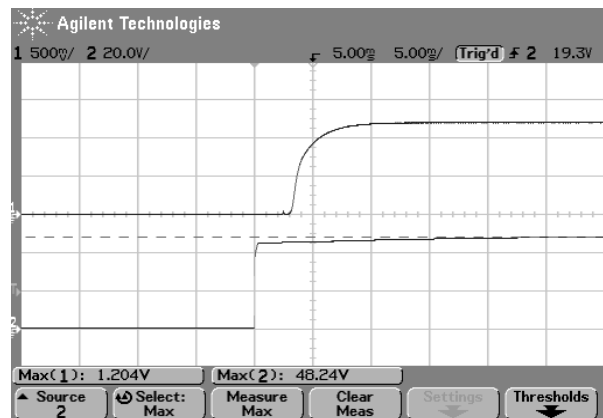

Figure 5 AGQ300 typical start-up from power on
ch1=Vout, ch2=Vin

Feature Description

CNT Function

Two CNT logic options are available. The CNT logic, CNT voltage and the module working state are as listed in the following table.

| | L | H | OPEN |
|---|-----|-----|------|
| N | ON | OFF | OFF |
| P | OFF | ON | ON |

N: negative logic

P: positive logic

L: low voltage, $-0.7V \leq L \leq 1.2V$

H: high voltage, $3.5V \leq H \leq 12V$

ON: module is on

OFF: module is off

Open: CNT pin is left open

Note: Normally, $V_{CNT} \leq 12V$.

The following figure shows a few simple CNT circuits.

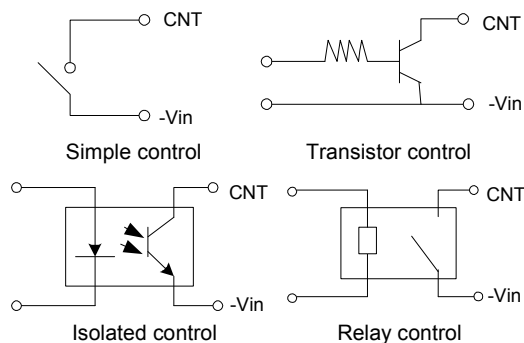

Figure 6 CNT circuit

Remote Sense

AGQ300-48S1V2 can remotely sense both lines of its output which moves the effective output voltage regulation point from the output terminals of the unit to the point of connection of the remote sense pins. This feature

automatically adjusts the real output voltage of AGQ300-48S1V2 in order to compensate for voltage drops in distribution and maintain a regulated voltage at the point of load.

When the converter is supporting loads far away, or is used with undersized cabling, significant voltage drop can occur at the load. The best defense against such drops is to locate the load close to the converter and to ensure adequately sized cable is used. When this is not possible, the converter can compensate for a drop of up to $10\%V_o$, through use of the sense leads.

When used, the +Sense and -Sense leads should be connected from the converter to the point of load as shown in Figure 7, using twisted pair wire, or parallel pattern to reduce noise effect. The converter will then regulate its output voltage at the point where the leads are connected. Care should be taken not to reverse the sense leads. If reversed, the converter will trigger over-voltage protection (OVP).

When not used, the +Sense lead must be connected with $+V_o$, and -Sense with $-V_o$. Although the output voltage can be increased by both the remote sense and the trim, the maximum increase for the output voltage is not the sum of both.

The maximum increase is the larger of either the remote sense or the trim.

Note that at elevated output voltages the maximum power rating of the module remains the same, and the output current capability will decrease correspondingly.

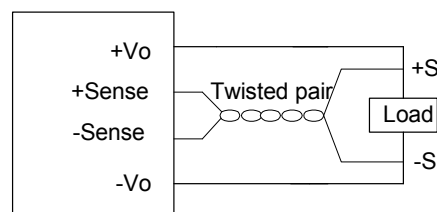

Figure 7 Sense connections

Trim

The +V_o output voltage of AGQ300-48S1V2 can be trimmed using the trim pin provided. Applying a resistor to the trim pin through a voltage divider from the output will cause the +V_o output to increase by up to 10% or decrease by up to 20%. Trimming up by more than 10% of the nominal output may activate the OVP circuit or damage the converter. Trimming down more than 20% can cause the converter to regulate improperly. If the trim pin is not needed, it should be left open.

Trim up

With an external resistor connected between the Trim and +Sense pins, the output voltage set point increases (see Figure 8).

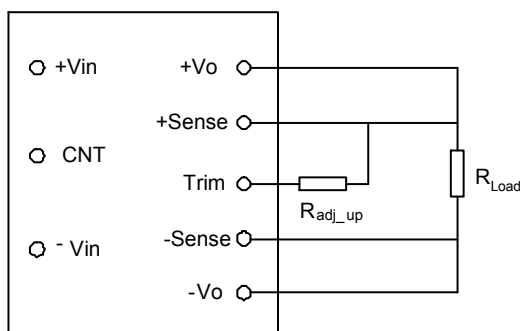

Figure 8 Trim up circuit

The following equation determines the required external-resistor value to obtain a percentage output voltage change of %.

$$R_{adj-up} = \frac{9.769 \times V_{nom} \times (100 + \Delta)}{0.6 \times \Delta} - \frac{1299.1}{\Delta} - 33.49 (k\Omega)$$

Note: $\Delta = (V_o - V_{nom}) \times 100 / V_{nom}$

Trim down

With an external resistor between the Trim and -Sense pins, the output voltage set point decreases (see Figure 9).

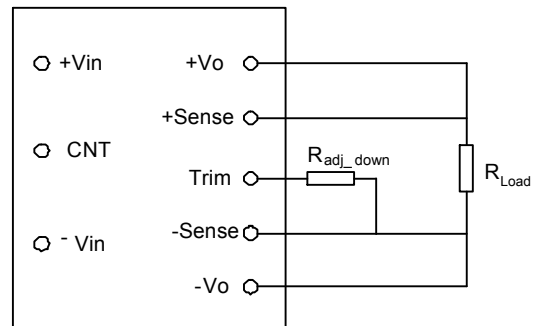

Figure 9 Trim down circuit

The following equation determines the required external-resistor value to obtain a percentage output voltage change of %.

$$R_{adj-down} = \frac{1299.1}{\Delta} - 33.49 (k\Omega)$$

Note: $\Delta = (V_{nom} - V_o) \times 100 / V_{nom}$

Although the output voltage can be increased by both the remote sense and the trim, the maximum increase for the output voltage is not the sum of both. The maximum increase is the larger of either the remote sense or the trim. Note that at elevated output voltages the maximum power rating of the module remains the same, and the output current capability will decrease correspondingly.

Minimum Load Requirements

There is no minimum load requirement for AGQ300-48S1V2.

Output Capacitance

High output current transient rate of change (high di/dt) loads may require high values of output capacitance to supply the instantaneous energy requirement to the load. To minimize the output voltage transient drop during this transient, low equivalent series resistance (ESR) capacitors may be required, since a high ESR will produce a correspondingly higher voltage drop during the current transient.

When the load is sensitive to ripple and noise, an output filter can be added to minimize the effects. A simple output filter to reduce output ripple and noise can be made by connecting a capacitor C1 across the output as shown in Figure 10. The recommended value for the output capacitor C1 is 470 μ F.

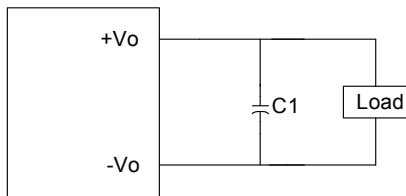

Figure 10 Output ripple filter

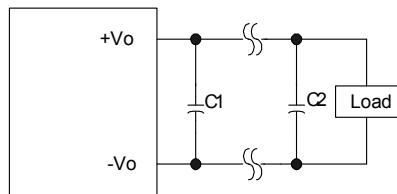

Figure 11 Output ripple filter for a distant load

Extra care should be taken when long leads or traces are used to provide power to the load. Long lead lengths increase the chance for noise to appear on the lines. Under these conditions C1 can be added across the load, with a 1 μ F ceramic capacitor C2 in parallel generally as shown in Figure 11.

Decoupling

Noise on the power distribution system is not always created by the converter. High speed analog or digital loads with dynamic power demands can cause noise to cross the power inductor back onto the input lines. Noise can be reduced by decoupling the load. In most cases, connecting a 10 μ F tantalum or ceramic capacitor in parallel with a 0.1 μ F ceramic capacitor across the load will decouple it. The capacitors should be connected as close to the load as possible.

Ground Loops

Ground loops occur when different circuits are given multiple paths to common or earth ground, as shown in Figure 12. Multiple ground points have slightly different potential and cause current flow through the circuit from one point to another. This can result in additional noise in all the circuits. To eliminate the problem, circuits should be designed with a single ground connection as shown in Figure 13.

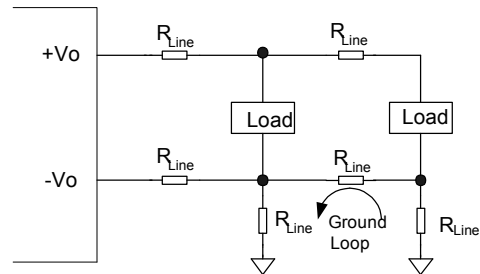

Figure 12 Ground loops

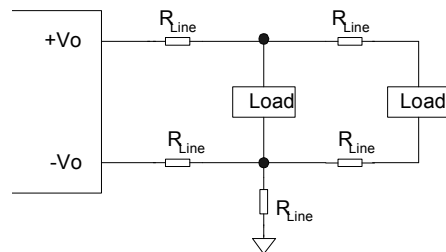

Figure 13 Single point ground

Output Over-Current Protection

AGQ300-48S1V2 features foldback current limiting as part of their over-current protection (OCP) circuits. When output current exceeds 110% to 140% of the rated current, such as during a short circuit condition, the module will shut down and attempt to restart normally after about 500ms.

Output Over-Voltage Protection

The output over-voltage protection consists of circuitry that monitors the voltage on the output terminals. If the voltage on the output terminals exceeds the over voltage protection threshold (120%~140% of the nominal output voltage), the module will shut down and attempt to restart normally after about 500ms.

Over-Temperature Protection

These modules feature an over-temperature protection circuit to safeguard against thermal damage. The module will work on intermittent mode when the maximum device reference temperature is exceeded. When the over-temperature condition is removed, the converter will automatically restart.

Input Reverse Voltage Protection

Under installation and cabling conditions where reverse polarity across the input may occur, reverse polarity protection is recommended. Protection can easily be provided as shown in Figure 14. In both cases the diode used is rated for 10A/100V. Placing the diode across the inputs rather than in-line with the input offers an advantage in that the diode only conducts in a reverse polarity condition, which increases circuit efficiency and thermal performance.

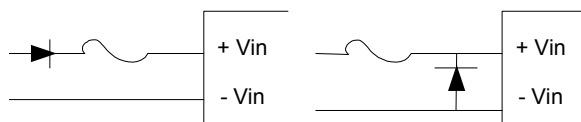

Figure 14 Reverse polarity protection circuit

Safety Consideration

For safety-agency approval of the system in which the power module is used, the power module must be installed in compliance with the spacing and separation requirements of the end-use safety agency standards, i.e., UL1950 and EN60950. AGQ300-48S1V2 input-to-output isolation is a basic insulation. The DC/DC power module should be installed in end-use equipment, in compliance with the requirements of the ultimate application, and is intended to be supplied by an isolated secondary circuit. When the supply to the DC/DC power module meets all the requirements for SELV (<60Vdc), the output is considered to remain within SELV limits (level 3). If connected to a 60Vdc power system, double or reinforced insulation must be provided in the power supply that isolates the input from any hazardous voltages, including the AC mains. One input pin and one output pin are to be grounded or both the input and output pins are to be kept floating. Single fault testing in the power supply must be performed in combination with the DC/DC power module to demonstrate that the output meets the requirement for SELV. The input pins of the module are not operator accessible.

Note: Do not ground either of the input pins of the module, without grounding one of the output pins. This may allow a non-SELV voltage to appear between the output pin and ground.

Fusing

AGQ300-48S1V2 has no internal fuse. An external fuse must always be employed! To meet international safety requirements, a 250 Volt rated fuse should be used. If one of the

input lines is connected to chassis ground, then the fuse must be placed in the other input line.

Standard safety agency regulations require input fusing. Recommended rating is 10A for AGQ300-48S1V2.

Note: The fuse is fast blow type.

EMC

For conditions where EMI is a concern, a different input filter can be used. Figure 15 shows the filter designed to reduce EMI effects for AGQ300-48S1V2.

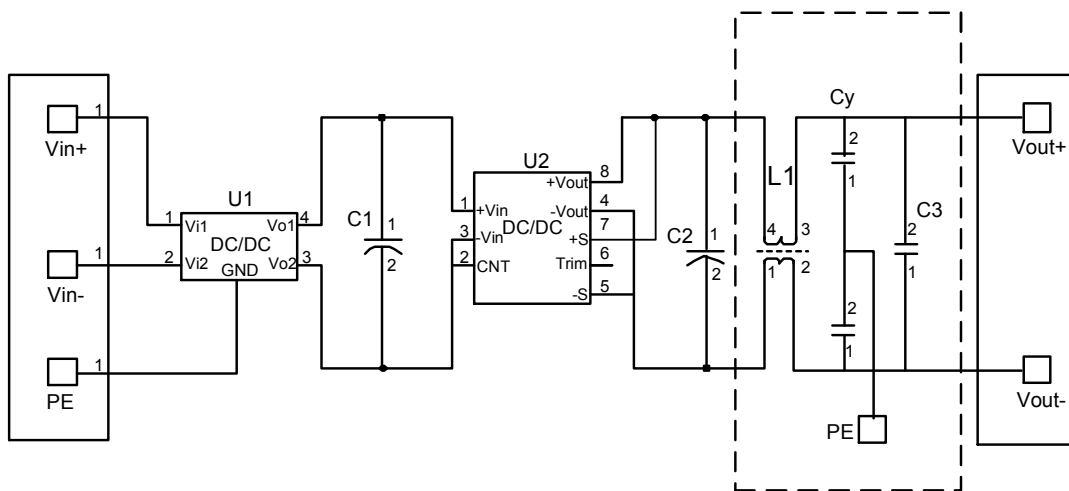

Figure 15 EMI reduction filter

| Component | Value/rating | Type | Description | Price |
|-----------|--------------|-----------------------|--|-------|
| C1 | 100uF/100V | Aluminum Electrolytic | 08010262: alum capacitor -100V-100μF-±20%-10*20-105°C-RoHS | - |
| C2 | 470uF/10V | Aluminum Electrolytic | 08010373: alum capacitor -10V-470μF-±20%-10*12.5-105°C-5000hrs-RoHS | - |

U1: 5A input filter module

Dashed part output filter: not needed

Thermal Consideration

Technologies

AGQ300-48S1V2 has ultra high efficiency at full load. With less heat dissipation and temperature-resistant components such as ceramic capacitors, these modules exhibit

good performance during pro-longed exposure to high temperatures. Maintaining the operating board temperature within the specified range helps keep internal component temperatures within their specifications, which in turn helps keep MTBF from falling below the specified rating. Proper cooling of the power modules is also necessary for reliable and consistent operation.

Thermal Management

Measuring the board temperature of the module as the method shown in Figure 16 can verify the proper cooling. If the module has a baseplate, the measurement location is at the center of the baseplate.

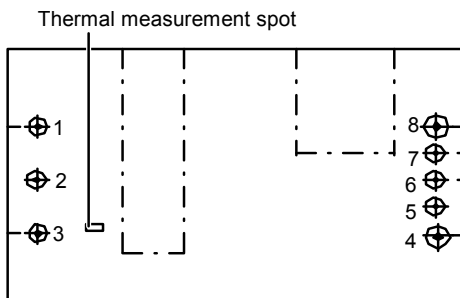

Figure 16 Temperature measurement spot

The module should work under 70°C ambient for the reliability of operation and the board temperature must not exceed 105°C while operating in the final system configuration. The measurement can be made with a surface probe after the module has reached thermal equilibrium. No heatsink is mounted, make the measurement as close as possible to the indicated position. It makes the assumption that the final system configuration exists and can be used for a test environment. Note that the board temperature of module must always be checked in the final system configuration to verify proper operation due to the variation in test conditions. Thermal management acts to transfer the heat dissipated by the module to the surrounding environment. The amount of power dissipated by the module as heat (PD) is got by the equation below:

$$PD = PI - PO$$

Where: PI is input power; PO is output power; PD is dissipated power.

Also, module efficiency (η) is defined as the following equation:

$$\eta = PO/PI$$

By eliminating the input power term, we can get the equation below from the above two equations:

$$PD = PO (1-\eta)/\eta$$

The module power dissipation then can be calculated through the equation.

Module Derating

With 48V input, 25°C ambient temperature, and 200LFM airflow, AGQ300-48S1V2 is rated for full power. The board temperature should be used to determine maximum temperature limits. The module cannot work continuously when the board temperature is over 100°C. The minimum operating temperature for AGQ300-48S1V2 is -40°C. The derating curve for open-frame is shown in Figure 17 and the derating curve with baseplate is shown in Figure 18.

Increasing airflow over the module enhances heat transfer via convection.

The module is not designed to operate for a long time with the baseplate temperature being above 100°C.

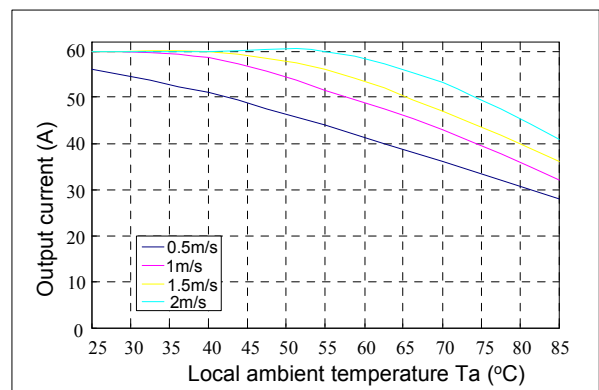

Figure 17 Derating curve of the module for open-frame, airflow rate from -Vin to +Vin

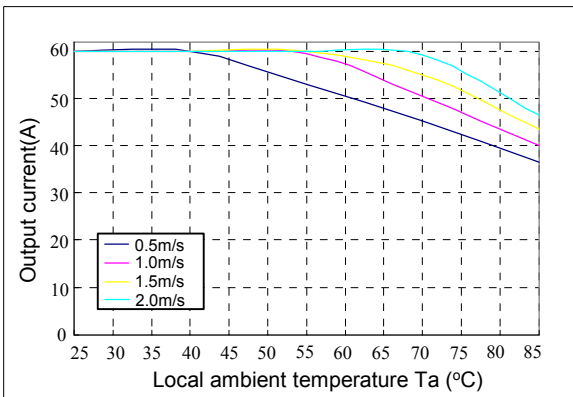

Figure 18 Derating curve of the module with baseplate, airflow rate from -Vin to +Vin

MTBF

The MTBF, calculated in accordance with Bellcore TR-NWT-000332, is 2,500,000 hours. Obtaining this MTBF in practice is entirely possible. If the board temperature is expected to exceed +25°C, then we also advise to orient the module for the best possible cooling in the air stream.

Emerson Network Power can supply replacements for converters from other manufacturers, or offer custom solutions. Please contact the factory for details.

Mechanical Considerations

Installation

Although AGQ300-48S1V2 can be mounted in any orientation, free air-flowing must be taken. Normally power components are always put at the end of the airflow path or have separate airflow paths. This can keep other system equipment cooler and increase component life spans.

Note:

1. There should be no electrical connection between the case and the PE or any module ports.
2. The fixing screw of the heatsink should not be too long. Please refer to the mechanical chart for detail.

Soldering

AGQ300-48S1V2 is compatible with standard wave soldering techniques. When wave soldering, the converter pins should be preheated for 20~30 seconds at 110°C, and wave soldered at 260°C for less than 10 seconds.

When hand soldering, the iron temperature should be maintained at 425°C and applied to the converter pins for less than 3 seconds. Longer exposure can cause internal damage to the converter. Cleaning can be performed with cleaning solvent IPA or with water.

Mechanical Chart (Top & Side View)

Open-Frame Product

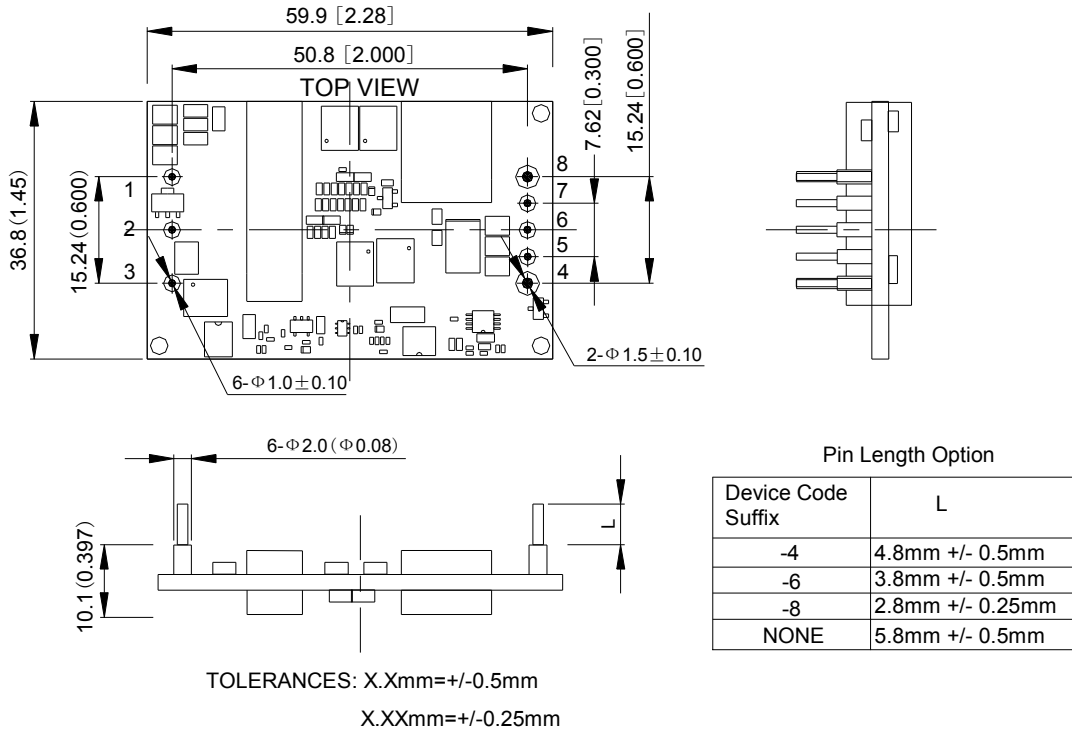

Baseplate Product

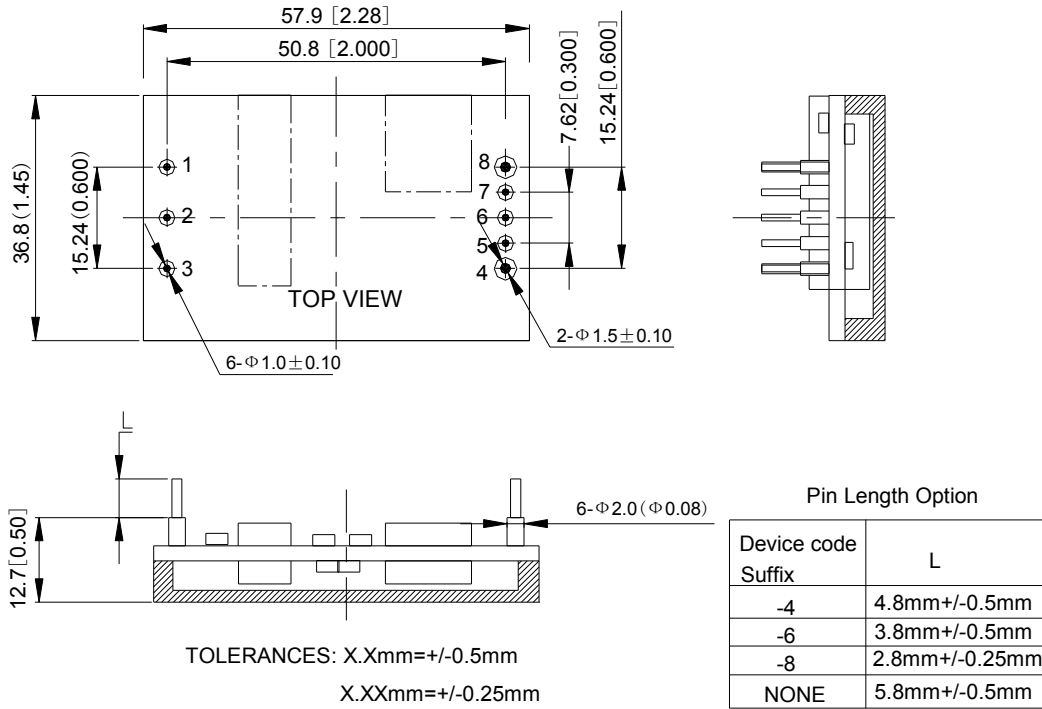

Pin Designations

| Pin number | Function | Pin number | Function |
|------------|----------|------------|----------|
| P1 | Vin (+) | P5 | -Sense |
| P2 | CNT | P6 | Trim |
| P3 | Vi (-) | P7 | +Sense |
| P4 | Vo (-) | P8 | Vo (+) |

Ordering Information

| Model number | Input voltage (V) | Output voltage (V) | Output current (A) | Ripple and noise (mV pp) | Efficiency (%) Typ. |
|--------------------|-------------------|--------------------|--------------------|--------------------------|---------------------|
| AGQ300-48S1V2-4L | 36 ~ 75 | 1.2 | 60 | Negative | 85 |
| AGQ300-48S1V2P-4L | 36 ~ 75 | 1.2 | 60 | Positive | 85 |
| AGQ300-48S1V2B-4L | 36 ~ 75 | 1.2 | 60 | Negative | 85 |
| AGQ300-48S1V2PB-4L | 36 ~ 75 | 1.2 | 60 | Positive | 85 |
| AGQ300-48S1V2-4Y | 36 ~ 75 | 1.2 | 60 | Negative | 85 |

有毒有害物质或元素标识表

| 部件名称 | 有毒有害物质或元素 | | | | | |
|--|-----------|----|----|------------------|------|-------|
| | 铅 | 汞 | 镉 | 六价铬 | 多溴联苯 | 多溴联苯醚 |
| | Pb | Hg | Cd | Cr ⁶⁺ | PBB | PBDE |
| 制成板 | ○ | ○ | ○ | ○ | ○ | ○ |
| ○：表示该有毒有害物质在该部件所有均质材料中的含量在 SJ/T-11363-2006 规定的限量要求以下。 ×：表示该有毒有害物质至少在该部件的某一均质材料中的含量超出 SJ/T-11363-2006 规定的限量要求 艾默生网络能源有限公司一直致力于设计和制造环保的产品，我们会通过持续的研究来减少和消除产品中的有毒有害物质。以下部件或应用中含有有毒有害物质是限于目前的技术水平无法实现可靠的替代或者没有成熟的解决方案： | | | | | | |
| 1. 器件的高温焊料中含有铅。 2. 电子器件的玻璃中含有铅。 3. 插针的铜合金中含有铅 | | | | | | |
| 适用范围：R6 产品 | | | | | | |

有毒有害物质或元素标识表

| 部件名称 | 有毒有害物质或元素 | | | | | |
|--|-----------|----|----|------------------|------|-------|
| | 铅 | 汞 | 镉 | 六价铬 | 多溴联苯 | 多溴联苯醚 |
| | Pb | Hg | Cd | Cr ⁶⁺ | PBB | PBDE |
| 制成板 | × | ○ | ○ | ○ | ○ | ○ |
| ○：表示该有毒有害物质在该部件所有均质材料中的含量在 SJ/T-11363-2006 规定的限量要求以下。 ×：表示该有毒有害物质至少在该部件的某一均质材料中的含量超出 SJ/T-11363-2006 规定的限量要求 艾默生网络能源有限公司一直致力于设计和制造环保的产品，我们会通过持续的研究来减少和消除产品中的有毒有害物质。以下部件或应用中含有有毒有害物质是限于目前的技术水平无法实现可靠的替代或者没有成熟的解决方案： | | | | | | |
| 1. 焊料（含器件的高温焊料）中含有铅。 2. 电子器件的玻璃中含有铅。 3. 插针的铜合金中含有铅 | | | | | | |
| 适用范围：R5 产品 | | | | | | |