

SPECIFICATIONS

Material: HEXSEALS: Silicone rubber conforms to A-A-59588, Class III, GR50 (unless otherwise specified).
Mounting Nut: HEXSEALS: Brass, nickel-plated
Temperature Range: HEXSEALS: -94° F to +400° F (-70° C to +204° C).
Pressure Range: Exceeds 15 psi internal and 1500 psi external.
Operational Life: 50,000 actuations (minimum).
Shelf Life: Excess of 25 years.
Resistant to: Salt spray, sunlight, ozone, weather, fungus, and most acids and lubricating oils.
Agency Recognition: UL & ULC Recognized to UL Std. 50

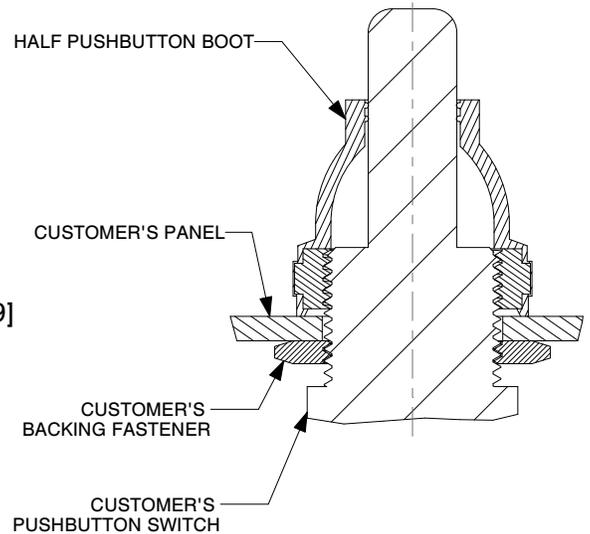
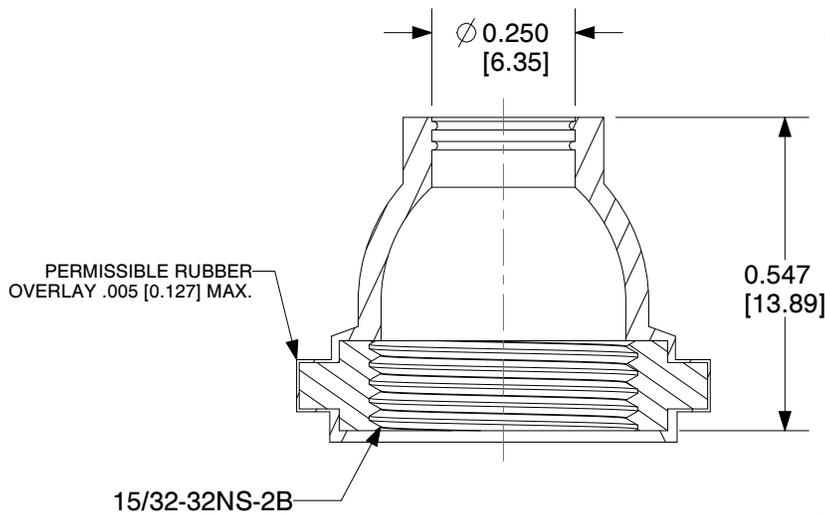
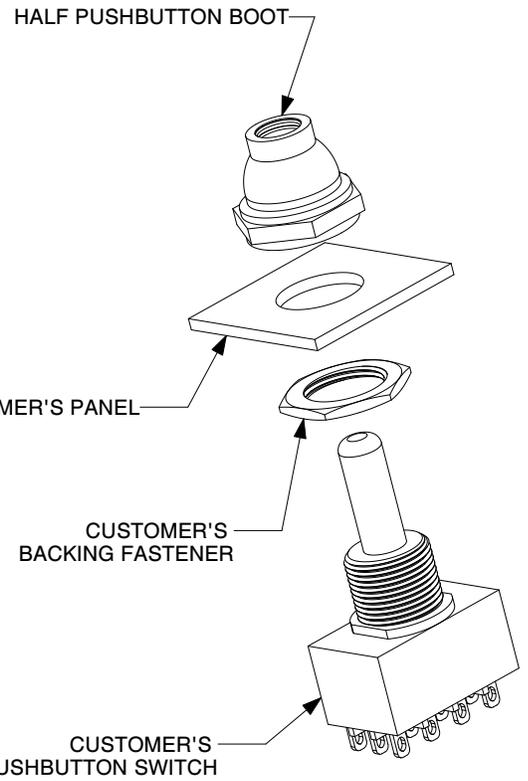
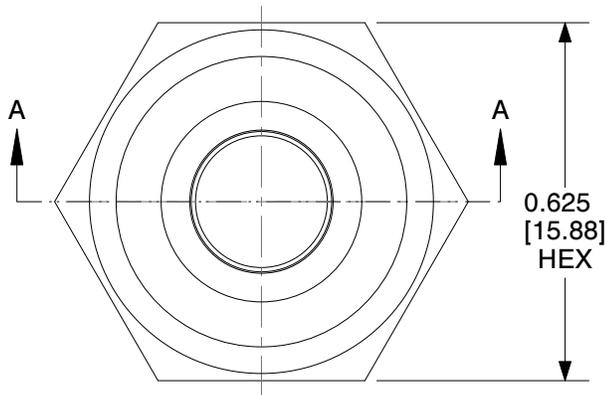

G	MAT'L CHANGED and REDRAWN	S.GOK	06.15.09
F	CAD COMPUTER GENERATED		09.23.02
E	UPDATED	R.C.	08.27.74
REV.	DESCRIPTION		DATE
MAXIMUM AND MINIMUM MEASUREMENTS ARE STATED DIRECTLY ON EACH DIMENSION.		ENG.	S. GOK 06.15.09
MAT'L: Silicone Rubber A-A-59588, GR.60		DWN:	B. FLAMCE 05.12.59
		CHKD.	J. CELLA 06.15.09
FINISH: CLEAR		SCALE	DWG.NO.
APM-HEXSEAL CORPORATION		1:1	N3030B

THIS DRAWING COVERS PROPRIETARY ITEM AND IS THE PROPERTY OF THE APM-HEXSEAL CORPORATION.
 THIS DRAWING IS NOT TO BE COPIED OR USED WITHOUT THE WRITTEN APPROVAL OF AN OFFICER OF THE APM-HEXSEAL CORPORATION.