

Power Operational Amplifier

FEATURES

- ◆ LOW COST
- ◆ HIGH VOLTAGE - 200 VOLTS
- ◆ HIGH OUTPUT CURRENT - 20 AMPS
- ◆ 170 WATT DISSIPATION CAPABILITY

APPLICATIONS

- ◆ MOTOR DRIVE
- ◆ MAGNETIC DEFLECTION
- ◆ PROGRAMMABLE POWER SUPPLIES
- ◆ INDUSTRIAL AUDIO AMPLIFIER

GENERAL DESCRIPTION

The MP240 operational amplifier is a surface mount constructed component that provides a cost effective solution in many industrial applications. The MP240 offers outstanding performance that rivals much more expensive hybrid components yet has a footprint of only 4.7 sq in. The MP240 has many optional features such as four-wire current limit sensing, a shut-down control and external compensation. In addition, the class A/B output stage biasing can be turned off for lower quiescent current with class C operation in applications where crossover distortion is less important such as when driving motors, for example. A boost voltage feature biases the output stage for close linear swings to the supply rail for extra efficient operation. The MP240 is built on a thermally conductive but electrically insulating substrate that can be mounted to a heat sink.

EQUIVALENT CIRCUIT DIAGRAM

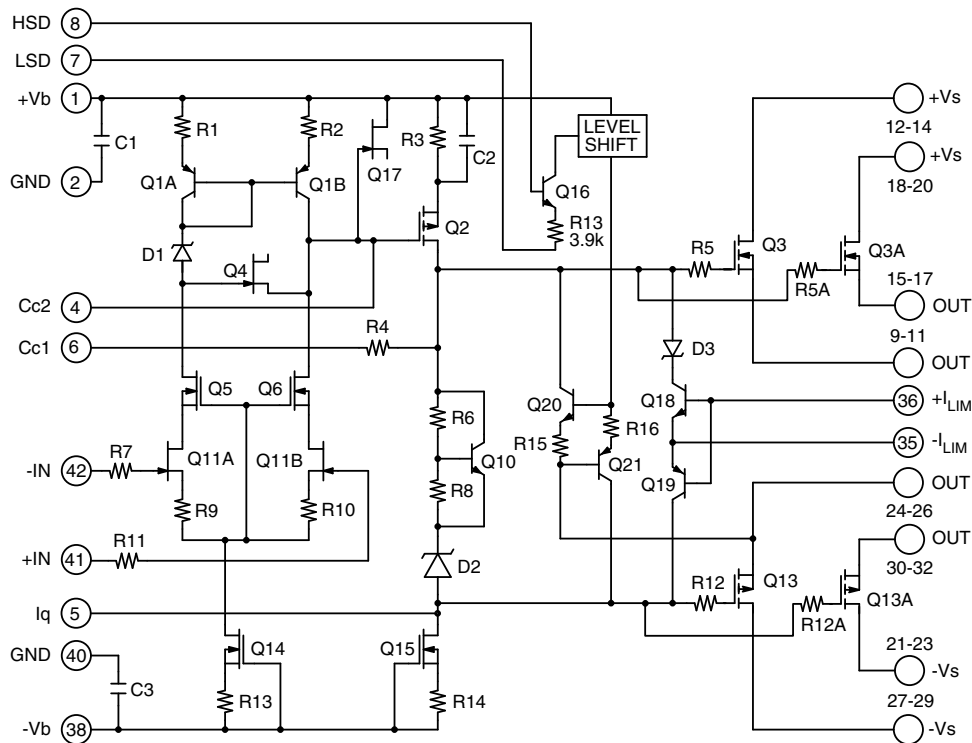

CHARACTERISTICS AND SPECIFICATIONS

ABSOLUTE MAXIMUM RATINGS

Parameter	Symbol	Min	Max	Units
SUPPLY VOLTAGE, $+V_S$ to $-V_S$			200	V
OUTPUT CURRENT, $+V_B$ (Note 6)			$+V_S + 15V$	V
POWER DISSIPATION, $-V_B$ (Note 6)			$-V_S - 15V$	V
OUTPUT CURRENT, peak, within SOA			25	A
POWER DISSIPATION, internal, DC			170	W
INPUT VOLTAGE			$+V_B$ to $-V_B$	V
TEMPERATURE, pin solder, 10s			225	°C
TEMPERATURE, junction (Note 2)			150	°C
TEMPERATURE RANGE, storage		-40	105	°C
OPERATING TEMPERATURE, case		-40	85	°C

SPECIFICATIONS

Parameter	Test Conditions	Min	Typ	Max	Units
INPUT					
OFFSET VOLTAGE			1	5	mV
OFFSET VOLTAGE vs. temperature	Full temperature range		20	50	$\mu V/^\circ C$
OFFSET VOLTAGE vs. supply				20	$\mu V/V$
BIAS CURRENT, initial (Note 3)				100	pA
BIAS CURRENT vs. supply				0.1	pA/V
OFFSET CURRENT, initial				50	pA
INPUT IMPEDANCE, DC			100		G Ω
INPUT CAPACITANCE			4		pF
COMMON MODE VOLTAGE RANGE				$+V_B - 15$	V
COMMON MODE VOLTAGE RANGE				$-V_B + 15$	V
COMMON MODE REJECTION, DC		92			dB
DIFFERENTIAL INPUT VOLTAGE				± 25	V
NOISE	1MHz bandwidth, 1k Ω R _s		5		μV RMS
SHUTDOWN, active	HSD - LSD	4.5	5	5.5	V
SHUTDOWN, inactive	HSD - LSD	-0.5	0	0.25	V
GAIN					
OPEN LOOP @ 15Hz	R _L = 1K Ω , C _c = 100pF	96			dB
GAIN BANDWIDTH PRODUCT @ 1MHz	C _c = 100pF		1.8		MHz
PHASE MARGIN	Full temperature range	60			°
OUTPUT					
VOLTAGE SWING	I _o = 20mA	$+V_S - 10$	$+V_S - 7$		V
VOLTAGE SWING	I _o = -20mA	$-V_S + 10$	$-V_S + 8$		V
VOLTAGE SWING	I _o = 20A, $+V_B = +V_S + 10V$	$+V_S - 3.0$	$+V_S - 2.0$		V
VOLTAGE SWING	I _o = -20A, $-V_B = -V_S - 10V$	$-V_S + 6.0$	$-V_S + 5.0$		V
CURRENT, continuous, DC		20			A
SLEW RATE, A _v = -10	C _c = 100pF	12	14		V/ μS

Parameter	Test Conditions	Min	Typ	Max	Units
SETTLING TIME, to 0.1%	$A_V = -1$, 10V Step, $C_C = 680\text{pF}$		5		μS
RESISTANCE, open loop	DC, 10A Load		0.2		Ω
POWER SUPPLY					
VOLTAGE		± 15	± 75	± 100	V
CURRENT, quiescent, total			16.5	25	mA
CURRENT, shutdown or class C quiescent			8.5		mA
CURRENT, boost supply			8.5		mA
THERMAL					
RESISTANCE, AC, junction to case (Note 5)	Full temp range, $f \geq 60\text{Hz}$			0.58	$^{\circ}\text{C/W}$
RESISTANCE, DC, junction to case	Full temp range, $f < 60\text{Hz}$			0.73	$^{\circ}\text{C/W}$
RESISTANCE, junction to air	Full temp range			14	$^{\circ}\text{C/W}$
TEMPERATURE RANGE, case		-40		85	$^{\circ}\text{C}$

NOTES:

1. Unless otherwise noted: $T_C = 25^{\circ}\text{C}$, compensation $C_C = 680\text{pF}$, DC input specifications are \pm value given, power supply voltage is typical rating. Amplifier operated without boost feature.
2. Long term operation at the maximum junction temperature will result in reduced product life. Derate internal power dissipation to achieve high MTBF.
3. Doubles for every 10°C of case temperature increase.
4. $+V_S$ and $-V_S$ denote the + and - output stage supply voltages. $+V_B$ and $-V_B$ denote the + and - input stage supply voltages (boost voltages).
5. Rating applies if the output current alternates between both output transistors at a rate faster than 60Hz.
6. Power supply voltages $+V_B$ and $-V_B$ must not be less than $+V_S$ and $-V_S$ respectively.

EXTERNAL CONNECTIONS

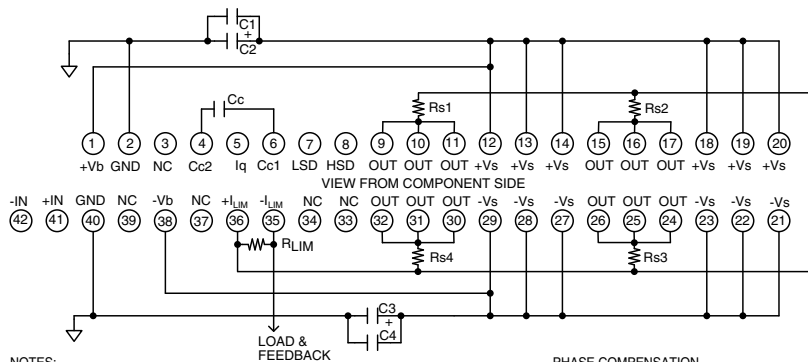

NOTES:

C_C IS NPO (COG) RATED FOR FULL SUPPLY VOLTAGE $+V_S$ TO $-V_S$. BOTH PINS 2 AND 40 REQUIRED CONNECTED TO SIGNAL GROUND. C_2 AND C_3 ELECTROLYTIC $\leq 10\mu\text{F}$ PER AMP OUTPUT CURRENT. C_1 AND C_4 HIGH QUALITY CERAMIC $\leq 0.1\mu\text{F}$. SEE TEXT FOR SELECTION OF VALUES FOR $R_{s1} - R_{s4}$.

PHASE COMPENSATION

C_C	GAIN W/O BOOST	GAIN W/BOOST	TYP. SLEW RATE
680pF	≤ 1	≤ 3	3V/ μS
330pF	≤ 3	≤ 6	6V/ μS
100pF	≤ 10	≤ 13	14V/ μS

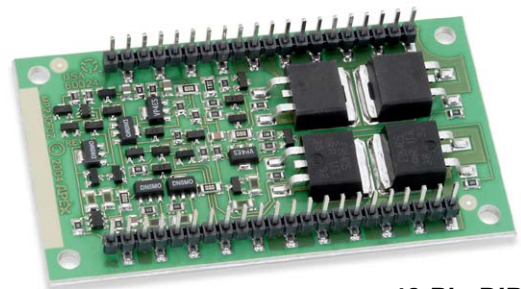

**42-Pin DIP
Package Style FC**

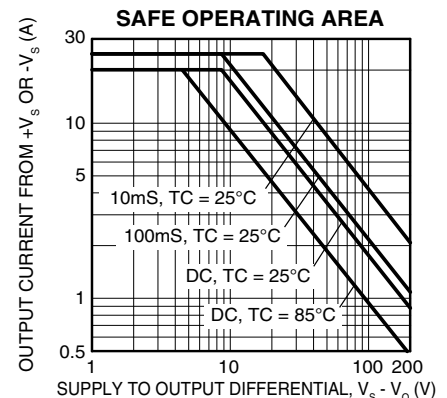
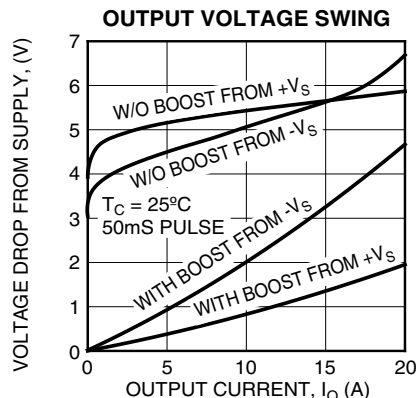
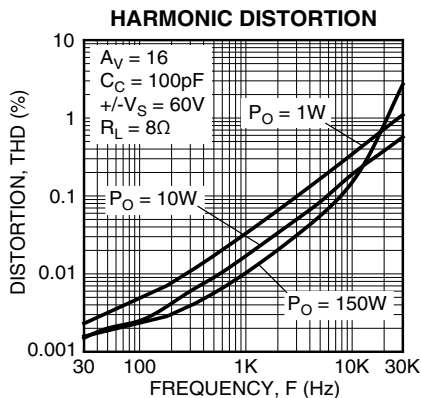
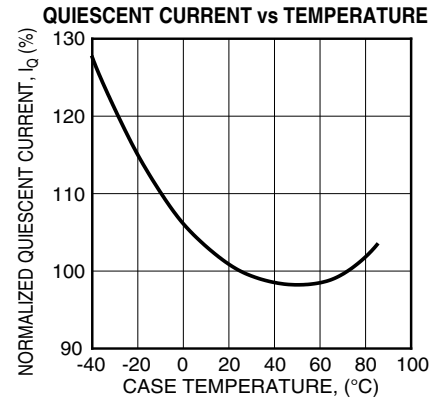
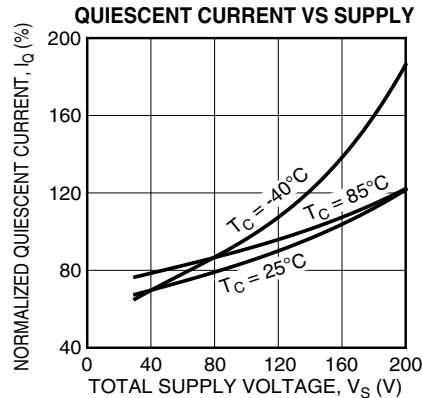
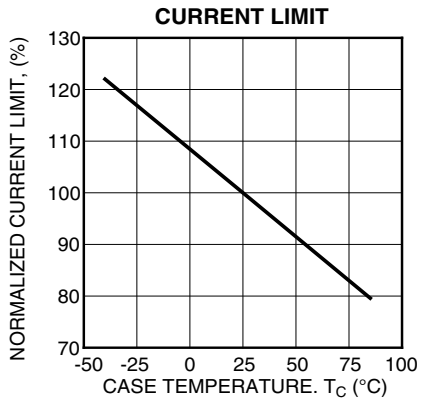
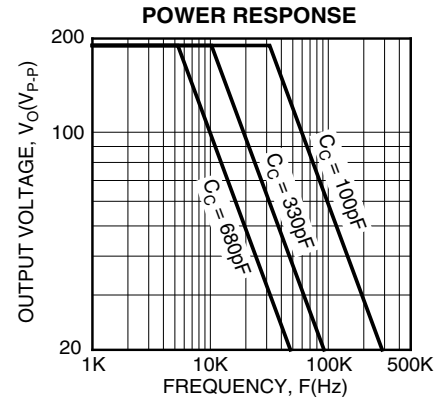
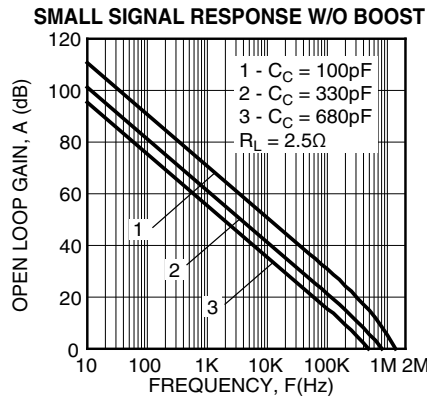
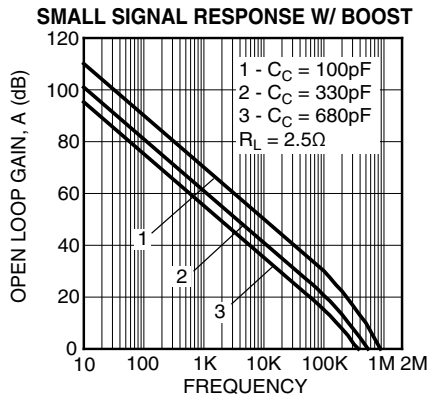
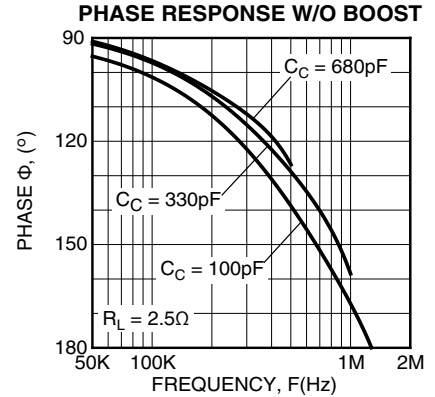
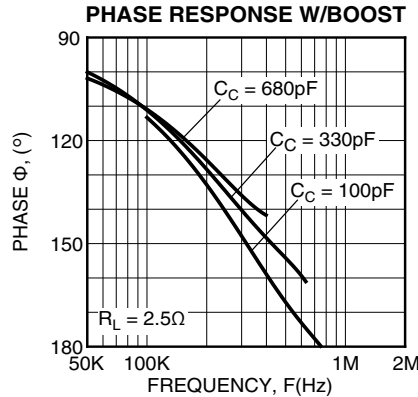
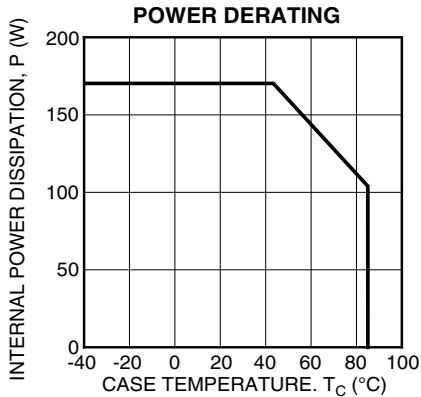

TYPICAL APPLICATION

MOTOR POSITION CONTROL

The MOSFET output stage of the MP240 provides superior SOA performance compared to bipolar output stages where secondary breakdown is a concern. The extended SOA is ideal in motor drive applications where the back EMF of the motor may impose simultaneously both high voltage and high current across the output stage transistors. In the figure above a mechanical to electrical feedback position converter allows the MP240 to drive the motor in either direction to a set point determined by the DAC voltage.

The MP400 is ideally suited to driving both piezo actuation and deflection applications off of a single low voltage supply. The circuit above boosts a system 24V buss to 350V to drive an ink jet print head. The MP400s high speed deflection amplifier is biased for single supply operation by external resistors R2 – R6, so that a 0 to 5V DAC can be used as the input to the amplifier to drive the print head from 0 to >300V.

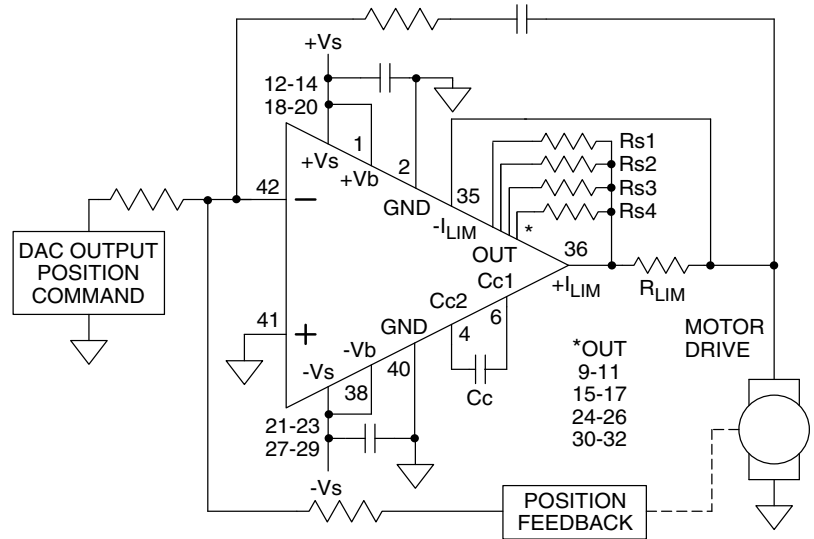

GENERAL

Please read Application Note 1 “General Operating Considerations” which covers stability, power supplies, heat sinking, mounting, current limit, SOA interpretation, and specification interpretation. Visit www.cirrus.com for design tools that help automate tasks such as calculations for stability, internal power dissipation, current limit, heat sink selection, Cirrus’s complete Application Notes library, Technical Seminar Workbook and Evaluation Kits.

GROUND PINS

The MP240 has two ground pins (pins 2, 40). These pins provide a return for the internal capacitive bypassing of the small signal stages of the MP240. The two ground pins are not connected together on the substrate. Both of these pins are required to be connected to the system signal ground.

BALANCING RESISTOR SELECTION (R_{S1} - R_{S4})

The MP240 uses parallel sets of output transistors. To ensure that the load current is evenly shared among the transistors external balancing resistors R_{S1} - R_{S4} are required. To calculate the required value for each of the resistors use: $R = 4.5/I^2$, where I is the maximum expected output current. For example, with a maximum output current of 10A each balancing resistor should be 0.045 ohms. Each resistor dissipates 1.125W at the maximum current. Use a non-inductive 2W rated resistor. A ready source for such resistors is the IRC resistor series LR available from Mouser Electronics.

SAFE OPERATING AREA

The MOSFET output stage of the MP240 is not limited by second breakdown considerations as in bipolar output stages. Only thermal considerations and current handling capabilities limit the SOA (see Safe Operating Area graph on previous page). The output stage is protected against transient flyback by the parasitic diodes of the output stage MOSFET structure. However, for protection against sustained high energy flyback external fast-recovery diodes must be used.

COMPENSATION

The external compensation capacitor C_c is connected to pins 4 and 6. Unity gain stability can be achieved with $C_c = 680\text{pF}$ for a minimum phase margin of 60 degrees. At higher gains more phase shift can usually be tolerated and C_c can be reduced resulting in higher bandwidth and slew rate. Use the typical operating curves as a guide to

select C_c . A 200V NPO (COG) type capacitor is required. Boost operation requires more compensation or higher gains than with normal operation due to the increased capacitance of the output transistors when the output signal swings close to the supply rails.

OVERVOLTAGE PROTECTION

Although the MP240 can withstand differential input voltages up to $\pm 25V$, in some applications additional external protection may be needed. 1N4148 signal diodes connected anti-parallel across the input pins is usually sufficient. In more demanding applications where bias current is important diode connected JFETs such as 2N4416 will be required. See Q1 and Q2 in Figure 1. In either case the differential input voltage will be clamped to $\pm 0.7V$. This is sufficient overdrive to produce the maximum power bandwidth. Some applications will also need over-voltage protection devices connected to the power supply rails. Unidirectional zener diode transient suppressors are recommended. The zeners clamp transients to voltages within the power supply rating and also clamp power supply reversals to ground. Whether the zeners are used or not the system power supply should be evaluated for transient performance including power-on overshoot and power-off polarity reversals as well as line regulation. See Z1 and Z2 in Figure 1.

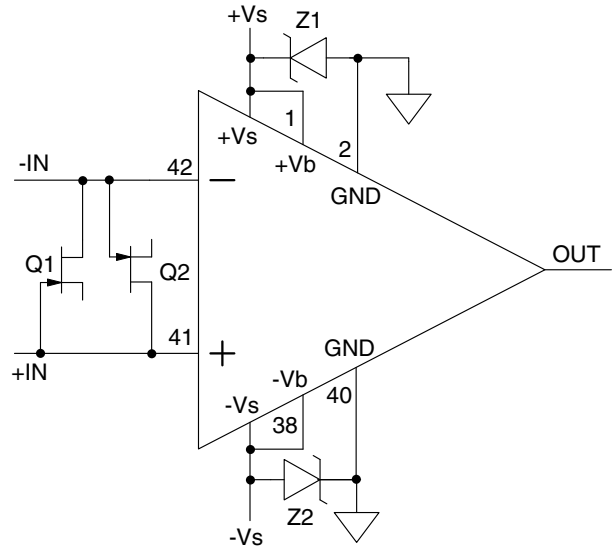

FIGURE 1: OVERVOLTAGE PROTECTION

POWER SUPPLY BYPASSING

Bypass capacitors to power supply terminals $+V_s$ and $-V_s$ must be connected physically close to the pins to prevent local parasitic oscillation in the output stage of the MP240. Use electrolytic capacitors at least $10\mu F$ per output amp required. Bypass the electrolytic capacitors with high quality ceramic capacitors $0.1\mu F$ or greater. In most applications power supply terminals $+V_b$ and $-V_b$ will be connected to $+V_s$ and $-V_s$ respectively. Although $+V_b$ and $-V_b$ are bypassed internally it is recommended to bypass $+V_b$ and $-V_b$ with $0.1\mu F$ externally. Additionally ground pins 2 and 40 must be connected to the system signal ground.

CURRENT LIMIT

The two current limit sense lines are to be connected directly across the current limit sense resistor. For the current limit to work correctly pin 36 must be connected to the amplifier output side and pin 35 connected to the load side of the current limit resistor R_{LIM} as shown in Figure 2. This connection will bypass any parasitic resistances R_p , formed by socket and solder joints as well as internal amplifier losses. The current limiting resistor may not be placed anywhere in the output circuit except where shown in Figure 2. The value of the current limit resistor can be calculated as follows: $R_{LIM} = .65/I_{LIMIT}$

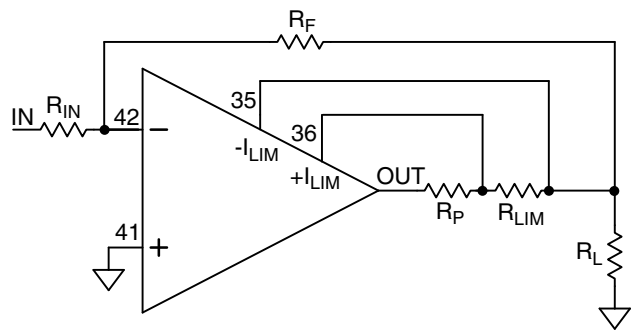

FIGURE 2: 4 WIRE CURRENT LIMIT

BOOST OPERATION

With the boost feature the small signal stages of the amplifier are operated at a higher supply voltages than the amplifier's high current output stage. $+V_b$ (pin 1) and $-V_b$ (pin 38) are connected to the small signal stages. An additional 10V on the $+V_b$ and $-V_b$ pin is sufficient to allow the small signal stages to drive the output stage into the triode region and improve the output voltage swing for extra efficient operation when required. When the boost feature is not needed $+V_s$ and $-V_s$ are connected to $+V_b$ and $-V_b$ respectively. $+V_b$ and $-V_b$ must not be operated at supply voltages less than $+V_s$ and $-V_s$ respectively.

SHUTDOWN

The output stage is turned off by applying a 5V level to HSD (pin 8) relative to LSD (pin 7). This is a non-latching circuit. As long as HSD remains high relative to LSD the output stage will be turned off. LSD will normally be tied to signal ground but LSD may float from $-V_B$ to $+V_B - 15V$. Shutdown can be used to lower quiescent current for standby operation or as part of a load protection circuit.

BIAS CLASS OPTION

Normally pin 5 (Iq) is left open. But when pin 5 is connected to pin 6 (Cc1) the quiescent current in the output stage is disabled. This results in lower quiescent power, but also class C operation of the output stage and the resulting crossover distortion. In many applications, such as driving motors, the distortion may be unimportant and lower standby power dissipation is an advantage.

CONTACTING CIRRUS LOGIC SUPPORT

For all Apex Precision Power product questions and inquiries, call toll free 800-546-2739 in North America.

For inquiries via email, please contact tucson.support@cirrus.com.

International customers can also request support by contacting their local Cirrus Logic Sales Representative.

To find the one nearest to you, go to www.cirrus.com

IMPORTANT NOTICE

Cirrus Logic, Inc. and its subsidiaries ("Cirrus") believe that the information contained in this document is accurate and reliable. However, the information is subject to change without notice and is provided "AS IS" without warranty of any kind (express or implied). Customers are advised to obtain the latest version of relevant information to verify, before placing orders, that information being relied on is current and complete. All products are sold subject to the terms and conditions of sale supplied at the time of order acknowledgment, including those pertaining to warranty, indemnification, and limitation of liability. No responsibility is assumed by Cirrus for the use of this information, including use of this information as the basis for manufacture or sale of any items, or for infringement of patents or other rights of third parties. This document is the property of Cirrus and by furnishing this information, Cirrus grants no license, express or implied under any patents, mask work rights, copyrights, trademarks, trade secrets or other intellectual property rights. Cirrus owns the copyrights associated with the information contained herein and gives consent for copies to be made of the information only for use within your organization with respect to Cirrus integrated circuits or other products of Cirrus. This consent does not extend to other copying such as copying for general distribution, advertising or promotional purposes, or for creating any work for resale.

CERTAIN APPLICATIONS USING SEMICONDUCTOR PRODUCTS MAY INVOLVE POTENTIAL RISKS OF DEATH, PERSONAL INJURY, OR SEVERE PROPERTY OR ENVIRONMENTAL DAMAGE ("CRITICAL APPLICATIONS"). CIRRUS PRODUCTS ARE NOT DESIGNED, AUTHORIZED OR WARRANTED TO BE SUITABLE FOR USE IN PRODUCTS SURGICALLY IMPLANTED INTO THE BODY, AUTOMOTIVE SAFETY OR SECURITY DEVICES, LIFE SUPPORT PRODUCTS OR OTHER CRITICAL APPLICATIONS. INCLUSION OF CIRRUS PRODUCTS IN SUCH APPLICATIONS IS UNDERSTOOD TO BE FULLY AT THE CUSTOMER'S RISK AND CIRRUS DISCLAIMS AND MAKES NO WARRANTY, EXPRESS, STATUTORY OR IMPLIED, INCLUDING THE IMPLIED WARRANTIES OF MERCHANTABILITY AND FITNESS FOR PARTICULAR PURPOSE, WITH REGARD TO ANY CIRRUS PRODUCT THAT IS USED IN SUCH A MANNER. IF THE CUSTOMER OR CUSTOMER'S CUSTOMER USES OR PERMITS THE USE OF CIRRUS PRODUCTS IN CRITICAL APPLICATIONS, CUSTOMER AGREES, BY SUCH USE, TO FULLY INDEMNIFY CIRRUS, ITS OFFICERS, DIRECTORS, EMPLOYEES, DISTRIBUTORS AND OTHER AGENTS FROM ANY AND ALL LIABILITY, INCLUDING ATTORNEYS' FEES AND COSTS, THAT MAY RESULT FROM OR ARISE IN CONNECTION WITH THESE USES.

Cirrus Logic, Cirrus, and the Cirrus Logic logo designs, Apex Precision Power, Apex and the Apex Precision Power logo designs are trademarks of Cirrus Logic, Inc. All other brand and product names in this document may be trademarks or service marks of their respective owners.