

SPECIFICATIONS

ELECTRICAL

(@28VDC, 115VAC, 60/400Hz)
1 million life cycles @ 1A

MECHANICAL

MECHANICAL LIFE	1 million operations
ACTUATION FORCE	700g (6.9 Newtons)
OPERATING TEMPERATURE	-40° to +85°C
CONTACT RESISTANCE	Less than 0.5 ohms

WIRING

GRAY	Switch
PURPLE	Switch
BLACK	Common

RoHS compliant

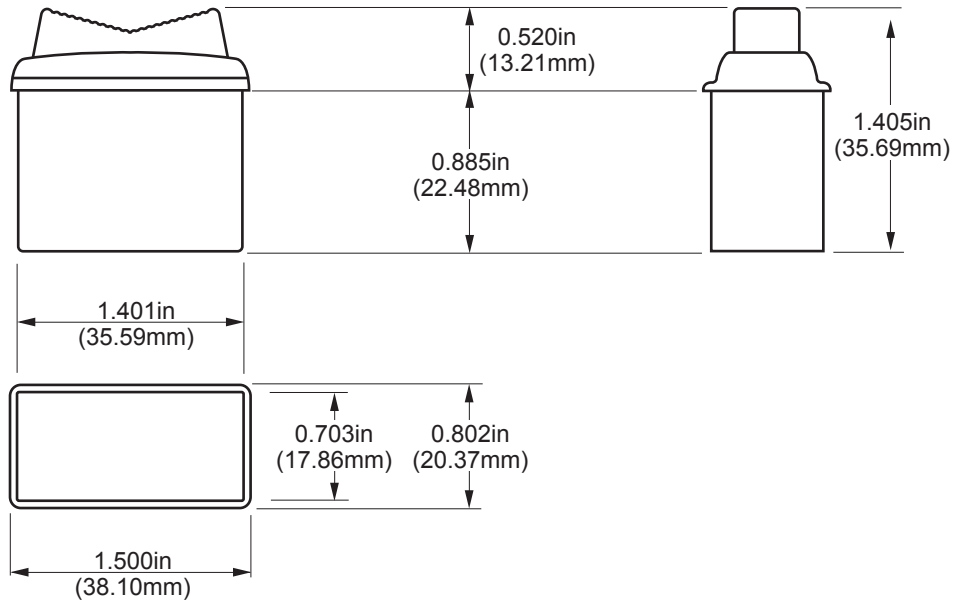

MOUNTING CUT-OUT DIMENSIONS

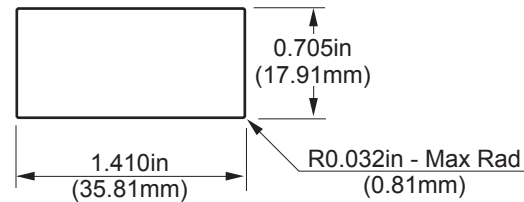

STEEL SPRING RETAINER *

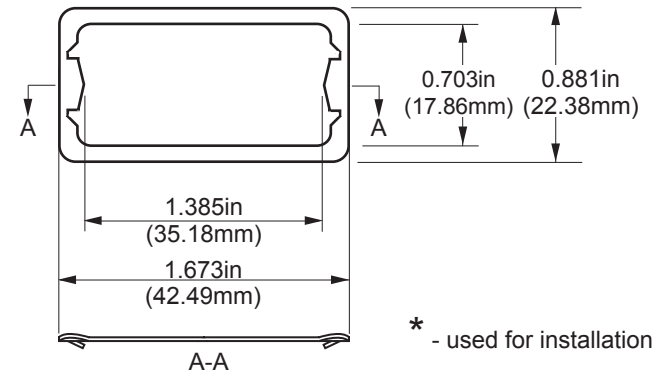

P/N	500-252	REV	A
DESCRIPTION	CH Rocker Switch		
PROPRIETARY AND CONFIDENTIAL THE INFORMATION CONTAINED IN THIS DRAWING IS THE SOLE PROPERTY OF CH PRODUCTS. ANY REPRODUCTION IN PART OR AS WHOLE WITHOUT THE WRITTEN PERMISSION OF CH PRODUCTS IS PROHIBITED.			