

ADIS16IMU1/PCBZ Breakout Board Wiki-Guide

OVERVIEW

The ADIS1613x, ADIS1636x, ADIS16375, ADIS16407 and ADIS1648x IMU products all use a 24-pin, dual-row, 1mm connector for their electrical interface. This mating connector for their interface supports surface-mount solder attachment but does not support direct attachment with ribbon cables. For those who would like to connect to these IMU/gyroscope products to an existing processor board, using a ribbon cable, the ADIS16IMU1/PCBZ provides a simple connector translation for this purpose.

Here is a picture of the contents that come with the ADIS16IMU1/PCBZ.



IMU/GYROSCOPE MOUNTING HOLES

The ADIS16IMU1/PCBZ provides several sets of mounting holes that line up with mounting holes and tabs on the following products: ADIS1613x, ADIS1636x, ADIS16375, ADIS1640x and ADIS1648x products. Please see the following picture for device mounting hole locations.

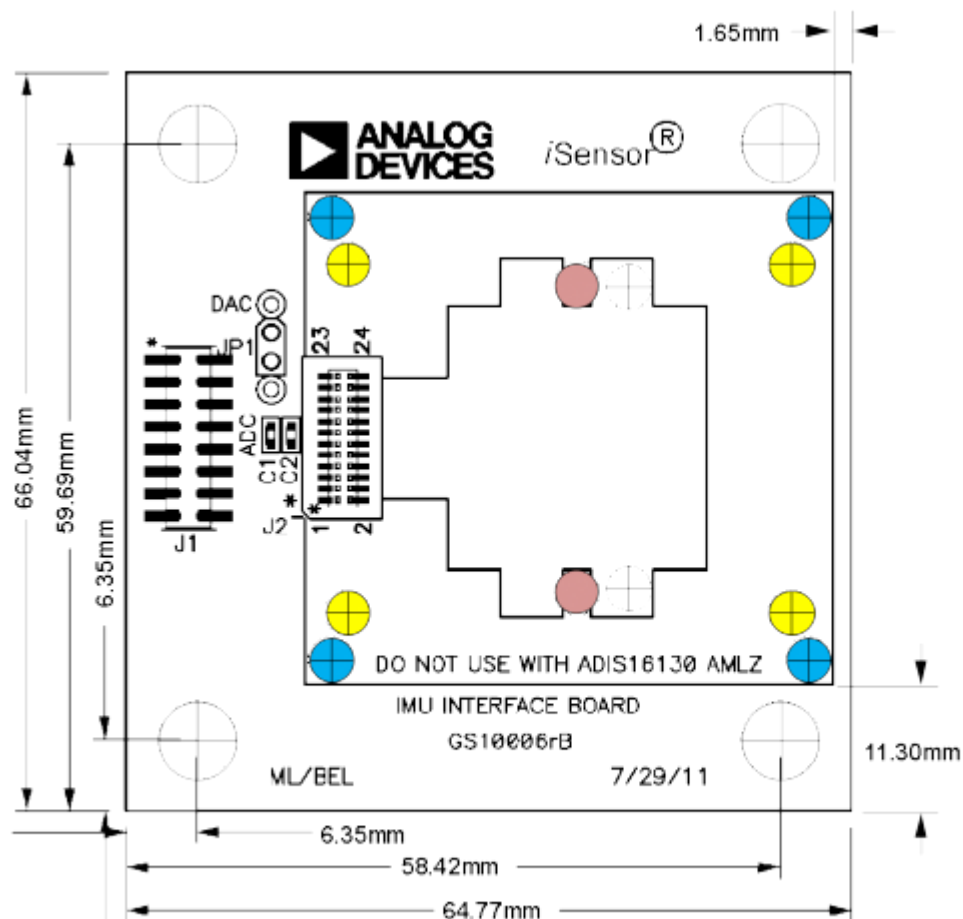

ADIS16133, ADIS16135, ADIS1636 Mounting

Use the M2x0.4x16mm machine screws (provided in pink bag) for mounting these products to the ADIS16IMU1/PCBZ and set their torque for 20 inch-ounces. The yellow-highlights in the top-view picture illustrate the location of the mounting holes for these products.



ADIS16360, ADIS16362, ADIS16364, ADIS16365, ADIS16367, ADIS16400, ADIS16405, ADIS16407 Mounting

Use the M2x0.4x4mm machine screws (provided in pink bag) for mounting these products to the ADIS16IMU1/PCBZ and set their torque for 20 inch-ounces. The pink-highlights in the top-view picture illustrate the location of the mounting holes for these products. For high-vibration environments, consider using more than 2 screws, per [AN-1045](#)



ADIS16375, ADIS16480, ADIS16485, ADIS16488 Mounting

Use the M2x0.4x16mm machine screws (provided in pink bag) for mounting these products to the ADIS16IMU1/PCBZ and set their torque for 20 inch-ounces. The blue-highlights in the top-view picture illustrate the location of the mounting holes for these products. Here is an example of the ADIS16IMU1/PCBZ, with an ADIS16485 AMLZ mounted to it.



Make sure that the connector pins are in alignment with J2 on the ADIS16IMU1/PCBZ, before pressing it into place.

Here is a close-up view, which shows the **correct connector alignment**.

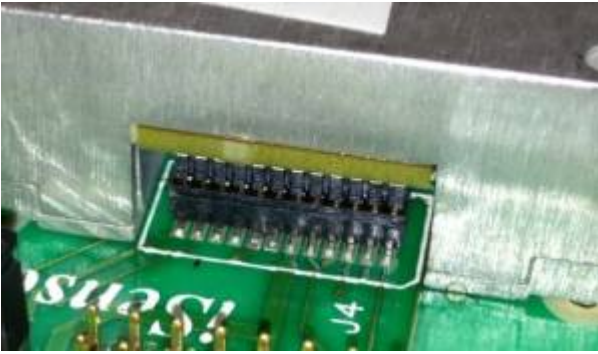

This picture provides an example of the an **incorrect connector alignment**. Note that this view is on the EVAL-ADISZ board, not the ADIS16IMU1/PCBZ.



INTERFACE CONNECTOR

J1 is the electrical connector that provides direct access to power, ground and critical digital I/O pins on the devices. It is a 16-pin, dual-row, 2-mm pitch connector that support 1mm ribbon cable systems.

Pin Assignments

Here is the pin assignments for J1, which is the connector that will interface with an embedded processor board.



Ribbon Cable Options

Check out the following link for ideas on how to make or purchase 16-pin, 1mm ribbon cables that can mate to J1 on the ADIS16IMU1/PCBZ.

[Acquiring 1mm ribbon cables](#)

ELECTRICAL SCHEMATIC

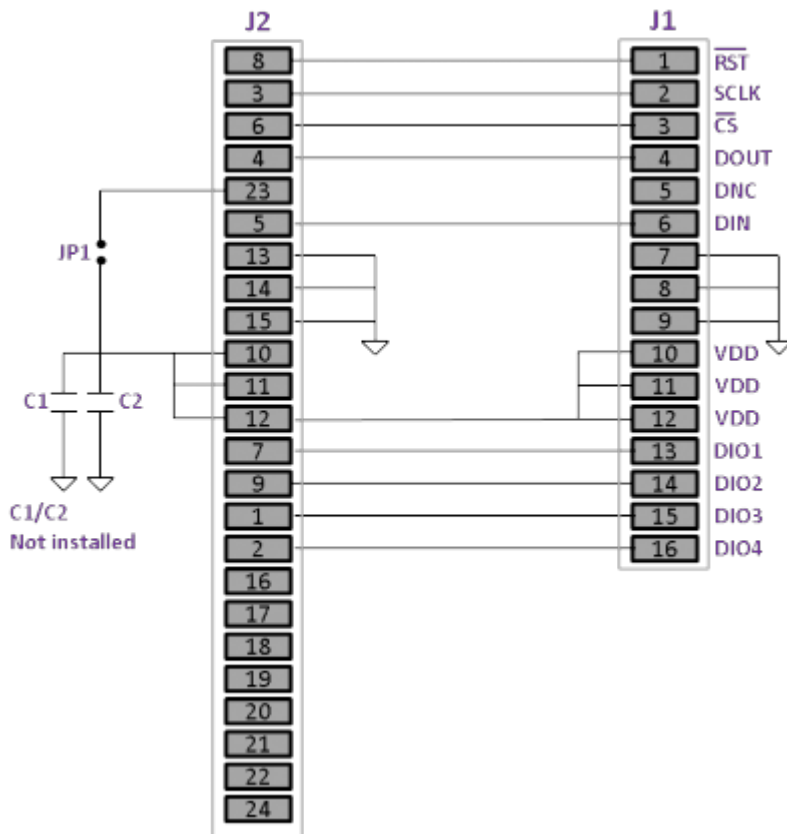



© Analog Devices, Inc. All rights reserved. Trademarks and registered trademarks are the property of their respective owners.



www.analog.com