

# Evaluation Board for the AD8479 Precision Difference Amplifier

## Features

- Enables quick breadboarding/prototyping**
- User-defined circuit configuration**
- Edge-mounted SMA connector provisions**
- Easy connection to test equipment**
- RoHS compliant**

## General Description

The AD8479R-EBZ is specifically designed to aid in the evaluation of the AD8479, a very high common-mode voltage precision difference amplifier. The evaluation board is a bare board (that is, there are no components soldered to the board; these must be ordered separately). Figure 1 and Figure 2 show component side and circuit side of the bare evaluation board. Figure 3 shows the evaluation board schematic.

The evaluation board is fabricated in a 4-layer printed circuit board (PCB). It accepts edge-mounted Subminiature A (SMA) connectors on the inputs and outputs, which allows efficient connection to test equipment and other circuits. The evaluation board components are primarily SMT 1206 case size, with the exception of the tantalum bypass capacitors (C3, C4), which are D (C7343) size.

Figure 4 and Figure 5 show the component side and circuit side of the evaluation board assembly drawing. Figure 6 and Figure 7 show the metal layout pattern for connecting the board to the current sense amplifier and to the supporting circuitry.

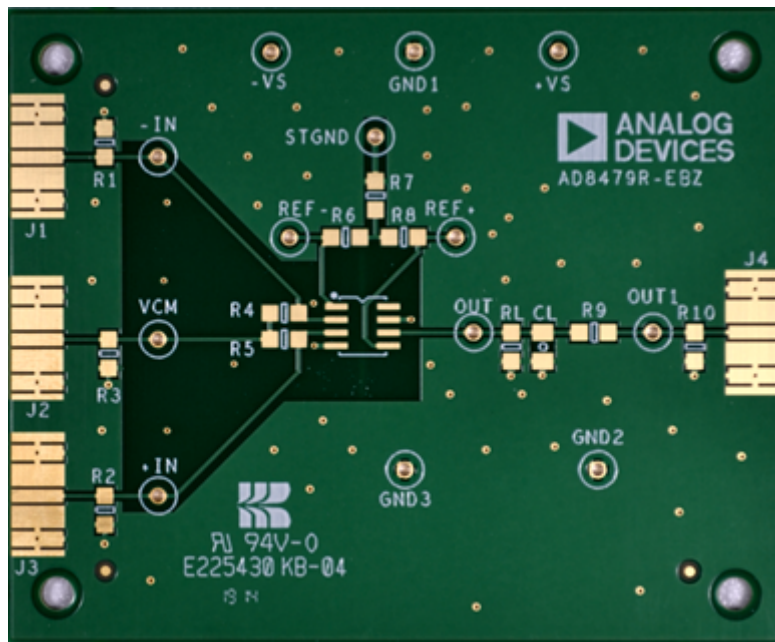

Figure 1. Component side of Evaluation Board

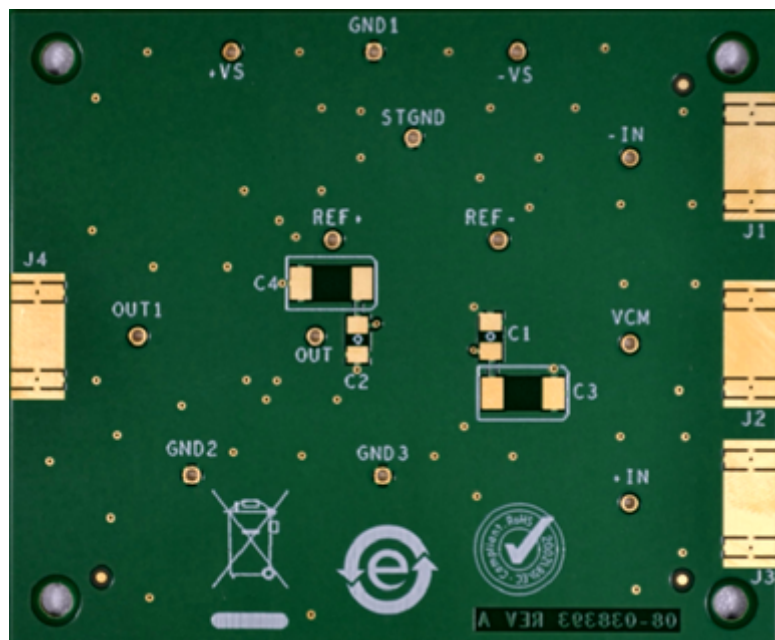

Figure 2. Circuit Side of Evaluation Board

## Evaluation Board Schematic

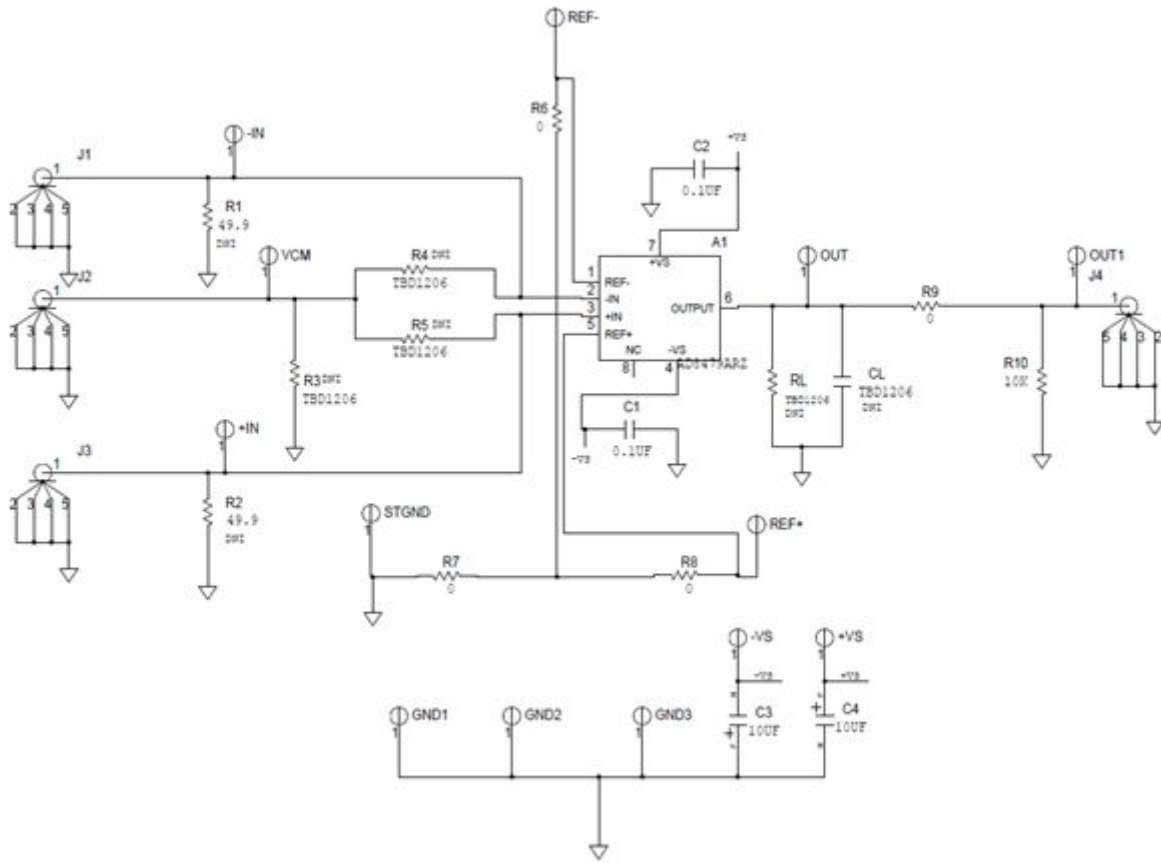

Figure 3. Evaluation Board Schematic

## ASSEMBLY DRAWING AND BOARD LAYOUT

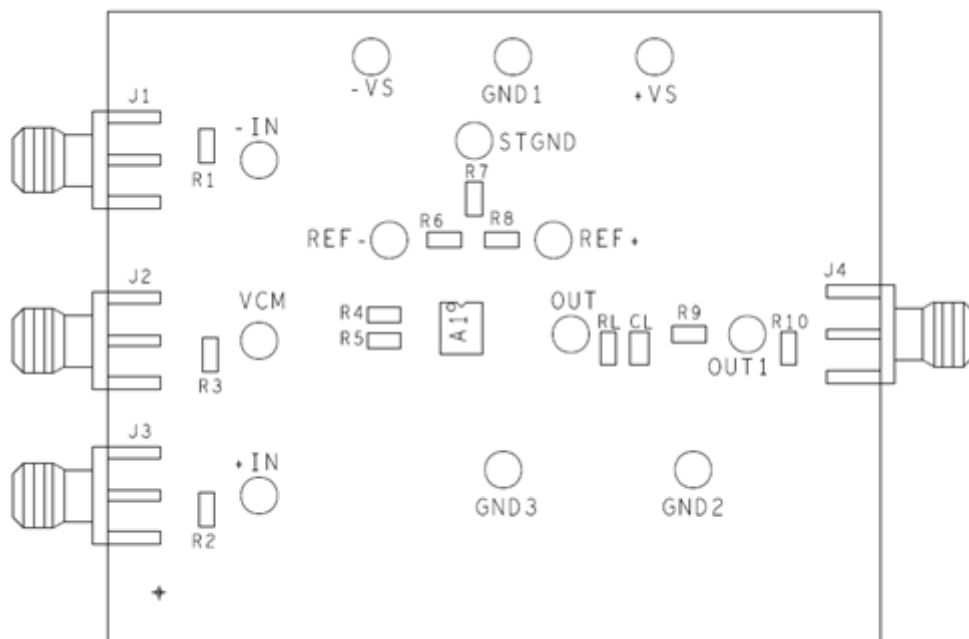

Figure 4. Component Side Assembly Drawing

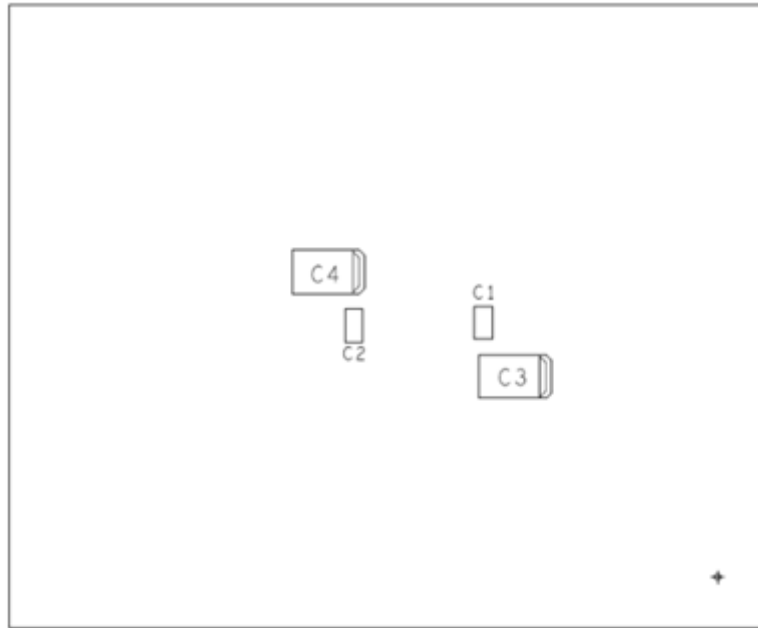

Figure 5. Circuit Side Assembly Drawing

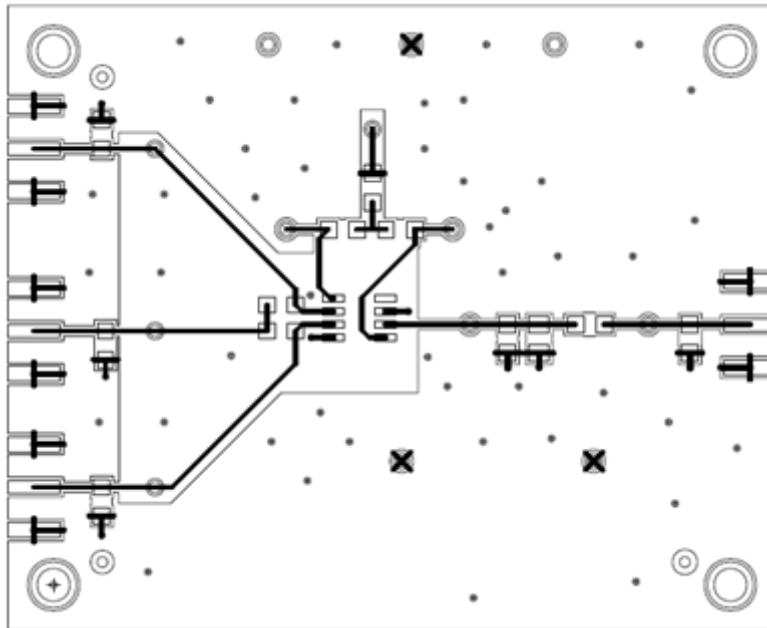

Figure 6. Component Side Layout

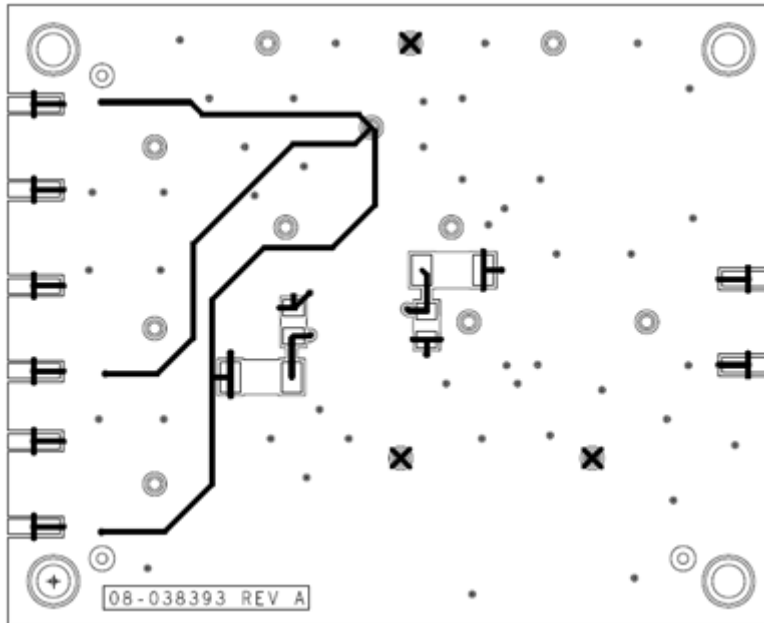

Figure 7. Circuit Side Layout

## Ordering Information

## Bill of Materials

Table 1. Bill of Materials

Quantity	Reference Designator	Package	Description
2	R1, R2	R1206	Resistor, 49.9 $\Omega$
4	R3, R4, R5, RL	R1206	User-defined resistor
4	R6, R7, R8, R9	R1206	Resistor, 0 $\Omega$
1	R10	R1206	Resistor, 10 k $\Omega$
2	C1, C2	c1206	Capacitor, 0.1 $\mu$ F
2	C3, C4	C7343-31	Capacitor, 10 $\mu$ F
1	CL	C1206	User-defined capacitor
13	+IN,-IN,+VS,-VS,OUT, VCM,GND1-GND3, OUT1,REF+,REF-,STGND	CNLOOPTP_D45	CONN-PCB pin vector
4	J1,J2,J3,J4	CN JOHNSON142-0701-801	SMA connector
1	U1	8-lead SOIC	AD8479ARZ

© Analog Devices, Inc. All rights reserved. Trademarks and registered trademarks are the property of their respective owners.



[www.analog.com](http://www.analog.com)