

HLS-442

Automotive Hydrogen Leak Sensor

General Description

The HLS-442 automotive hydrogen leak sensor monitors hydrogen concentrations of 0 – 4.4% in air. The sensor is a leak sensor developed in accordance to IEC 61508 (SIL2) and explosion protected according to ATEX 100a. The predicted concentration is transmitted to the host via the CAN bus interface. HLS-442 utilizes self-calibration that is performed automatically when operated in air with normal hydrogen concentration. Therefore, the HLS-442 should not continuously be operated in elevated background levels of hydrogen.

Ordering Information and Content Guide appear at end of datasheet.

Key Benefits & Features

The benefits and features of HLS-442, Automotive Hydrogen Leak Sensor are listed below:

Figure 1:
Added Value of Using HLS-442

Benefits	Features
<ul style="list-style-type: none"> High sensitivity and excellent selectivity to hydrogen gas 	<ul style="list-style-type: none"> 0–4.4% H₂ in air Accuracy ± 3000 ppm at normal operation
<ul style="list-style-type: none"> Low cross sensitivity 	<ul style="list-style-type: none"> Heated field-effect transistor technology No detection towards HC, H₂S, N₂, CO, CO₂, NO_x, H₂O Humidity influence not detectable
<ul style="list-style-type: none"> Fast response time 	<ul style="list-style-type: none"> Start-up time <5s Speed of response (t₉₀) < 2s Speed of recovery < 10s CAN bus interface 500 kbit/s (ISO11898-2) PWM output (on request)
<ul style="list-style-type: none"> Low power consumption 	<ul style="list-style-type: none"> 75 mA (typical)
<ul style="list-style-type: none"> Long-term stability and reliability 	<ul style="list-style-type: none"> ESD and EMC protection Operating temperature range –40°C to 85°C
<ul style="list-style-type: none"> Safety integrity level and explosion proof 	<ul style="list-style-type: none"> Designed for SIL2 (IEC 61508) and ATEX 100a zone 2
<ul style="list-style-type: none"> Long lifetime 	<ul style="list-style-type: none"> IP67 qualified with expected lifetime of 10 years

Applications

Detection of hydrogen gas leaks in hydrogen powered vehicles by installing the sensor

- in the cabin ceiling
- under the hood of the engine compartment
- beneath the trunk lid of hydrogen powered vehicles

Detection of hydrogen gas in and around hydrogen fueling stations

Block Diagram

The functional blocks of this device for reference are shown below:

Figure 2:
HLS-442 Block Diagram

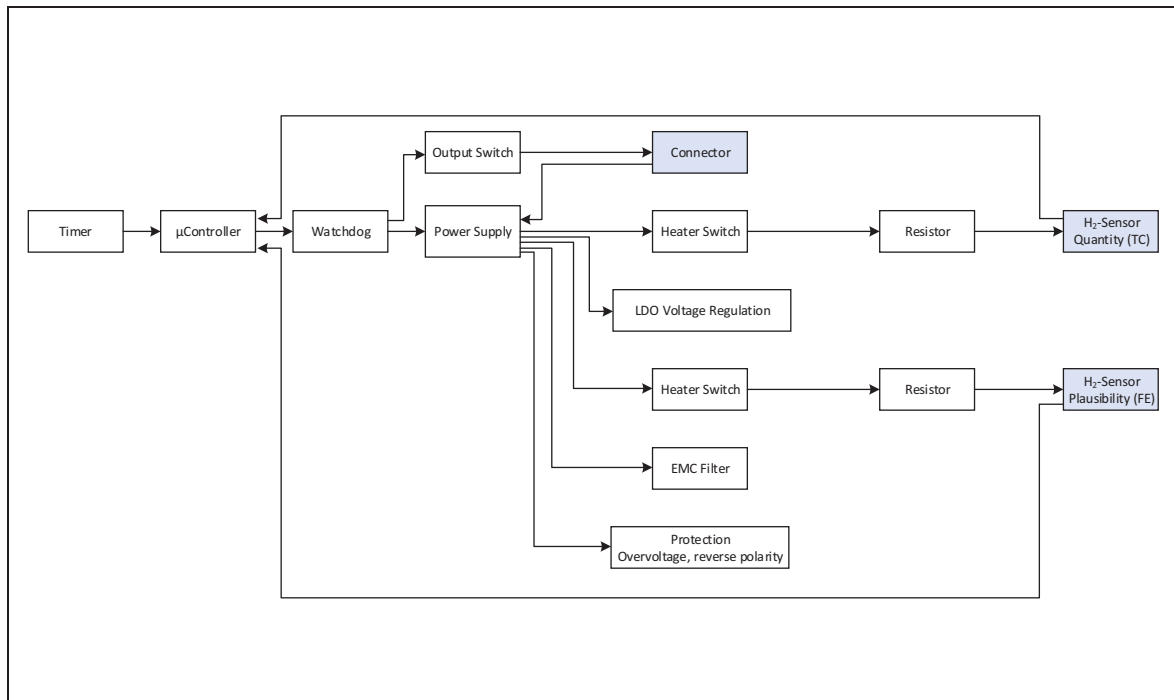

Figure 3:
HLS-442 Overview



Installation

The HLS-442 is designed for either a sealed installation against a wall (using a gasket) [Alt. 1] or an open-air [Alt. 2] installation. The sensor can be oriented in any direction but the gas inlet must not be blocked.

Retaining pins or bolts shall be max Ø5.5 mm.

Maximum mounting torque 10 Nm.

Figure 4:
Mounting Positions

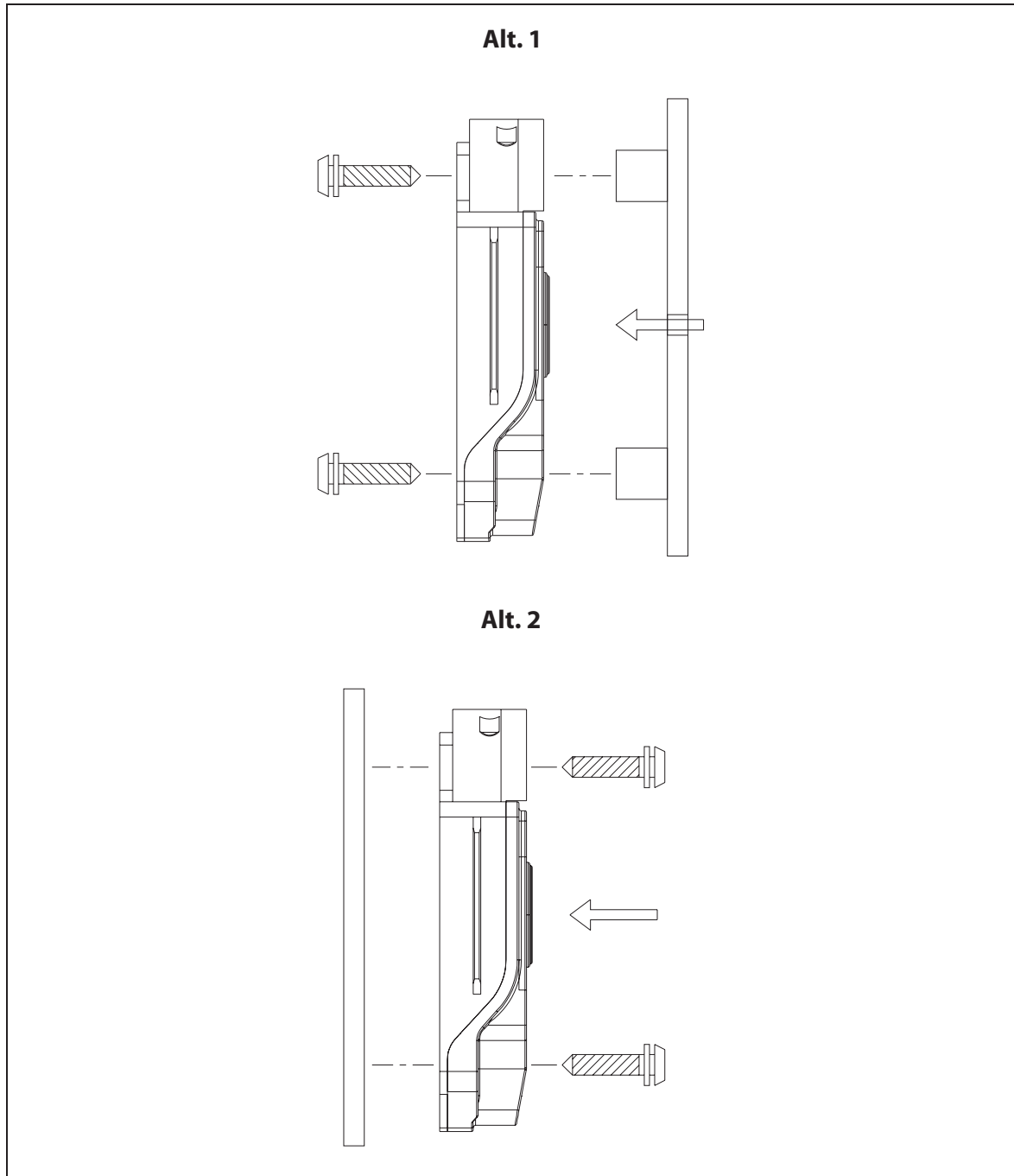

Electrical Interface

Electrical Connector

The sensor connector is A2100011199, 6-PIN Code A. Matching receptacle is a 6-pin MQS, TE Connectivity AMP p/n 1-967616-1 type A.

Figure 5:
Pin Coding AMP 1-967616-1 Type A



Figure 6:
Pin Assignment

Pin	Function
1	CAN – High
2	CAN – Low
3	Power UB0
4	Power UB1
5	Power UB2
6	GND

CAN Bus Interface

This section describes the CAN bus interface that is available in some variants of HLS-442.

Physical Interface

The physical interface is two-wire balanced, non-terminated. It is a high speed CAN interface (ISO 11898-2) with bus bit rate of 125, 250 or 500 kBit/s, depending on the variant of HLS-442.

Bus Identification

Each sensor and the control unit are identified on the bus by the CAN identity, CAN ID. The CAN ID is transmitted in the CAN data frame arbitration field. For the sensors the CAN ID is determined by the configuration of the power supply feeds, UB0 (pin 3), UB1 (pin 4) and UB2 (pin 5). The table below defines the sensor's CAN ID, VB denotes a power input connected to supply voltage level. Addresses are given in hexadecimal numbers and denoted with a leading "0x".

Figure 7:
Overview CAN ID Assignment By Power Supply Feeds

UB2	UB1	UB0	Sensor Number	CAN ID
		VB	1	0x640
	VB		2	0x648
	VB	VB	3	0x650
VB			4	0x658
VB		VB	5	0x660
VB	VB		6	0x668
VB	VB	VB	7	0x670

Messages From the Sensor

The main message sent from the sensor to the control unit is the Sensor Status Message, hereafter referred to as the SSM.

After 700 ms from power-ON of the sensor it will start sending the SSM frame as defined below. The SSM, after this event, is transmitted periodically with a 100 ms interval until the sensor is powered OFF. Besides the SSM, the sensor can also send a Wake-Up pulse. This is described in detail in Wake-Up Function. The Wake-Up pulse is separate from the SSM and has no impact on the SSM.

The figure below defines the data field of the SSM CAN data frame. The data field uses 8 bytes. The CAN ID as described earlier sets the arbitration field.

Figure 8:
CAN Matrix Message Layout

Parameter Name	Data Size	Physical Measurement Range	Value Range	b7	b6	b5	b4	b3	b2	b1	b0	Byte No.
H ₂ Concentration	8 bits	0 – 4.4 %	[20 -240]	H ₂ Concentration								0
Protection Value 1	8 bits			pv1								1
FE high	8 bits			FE high								2
CRC16 Byte 1 (Higher Byte)	8 bits			CRC16								3
FE low	2 bits			FE low		0						4
Protection Value 2	2 bits			pv2								4
Sensor Number	3 bits		[1 - 7]				UB 2	UB 1	UB 0			4
Msg. Counter	8 bits		[0 - 255]	Msg Counter								5
Sensor status	2 bits		[0 - 3]							status	0	6
Part number	5 bits		[1 - 31]	Part number							0	6
CRC16 Byte 2 (Lower Byte)	8 bits			CRC16								7

H₂ Concentration

0% is encoded with decimal number 20.

4.4% (44000 ppm) is encoded with decimal number 240.

The relation between detected H₂ concentration (in ppm) and concentration code as signaled in the message is:

$$(EQ1) \quad \text{Code} = \text{round}(H_2/200) + 20$$

$$(EQ2) \quad H_2 = (\text{code} - 20) * 200$$

Where round() denotes rounding towards the nearest integer.

Protection Value

The protection value offers a 10-bit consistency check of the transmitted concentration, status and message counter. The following pseudo code describes the algorithm forming the 10-bit value and how it is projected on to the protection value 1 and the protection value 2 bytes in the SSM.

code[7 - 0] denotes the set of 8 bits transmitted as code for representing the H₂ concentration.

status[1 - 0] denotes the set of two bits transmitted as code for representing sensor status.

msgcnt[6 - 0] denotes the set of 7 bits transmitted as code for representing message counter.

pv[9 - 0] denotes the set of 10 bits forming the protection value.

pv1[7 - 0] denotes the set of 8 bits transmitted as code for protection value 1.

pv2[1 - 0] denotes the set of 2 bits transmitted as code for protection value 2.

Figure 9:
Pseudo Code Description of Protection Value

Pseudo Code	Description
$pv[9 - 8] = status[1 - 0]$	Assign two most significant bits of pv as the status bits
$pv[7 - 0] = code[7 - 0]$	Assign 8 least significant bits of pv as the code bits
$pv[9 - 0] = pv[9 - 0] + msgcnt[1 - 0]$	To pv add the number formed by two least significant bits of the message counter
$pv[9 - 0] = NOT\ pv[9 - 0]$	Perform bitwise inverse of pv
$pv[9 - 0] = pv[9 - 0] + 1$	To pv add 1
$pv1[7 - 0] = pv[7 - 0]$	Form protection value 1 of the 8 least significant bits of the 10-bit protection value
$pv2[1 - 0] = pv[9 - 8]$	Form protection value 2 of the 2 most significant bits of the 10-bit protection value

FE High / FE Low

The raw FE signal is available in 10-bit resolution (1 step = 4mV). The high 8 bits are available in byte 2 and the lower 2 bits in byte 7, bit 6-7. The data range is 0-4092mV.

CRC16

Byte 3 and byte 7 form a 16-bit CRC value. The CRC is CCITT CRC16.

Sensor Number

Sensor Number is defined by power supply feeds and CAN ID assigned sensor number is repeated in byte 4 bit 2-4. The value sent is given in [Bus Identification](#).

Message Counter

The message counter is incremented by 1 after each transmission of a SSM frame. After the counter reaches 255 it wraps around and the next transmitted counter value becomes 0. At sensor start-up the message counter begins at 1.

Status

The figure below defines the status encoding of b1 and b2:

Figure 10:
The Status Encoding of b1 and b2

Status	Encoding b2:b1	Name	Description
0	0:0	No error	Sensor fully functional
1	0:1	Minor error	Main function ensured, but possible impairment of measuring quality.
2	1:0	Minor functional error	Main function ensured, but impaired (the sensor should be replaced)
3	1:1	Fatal functional error	Sensor is not functioning correctly.

Part Number

The part number defines the release number encoding of b3-b7.

PWM

This section describes the PWM output that is available on request for the HLS-442.

Physical Interface

The electrical connector is the same as in the variants with CAN bus interface (see Electrical Connector). The power can be applied to any of pin 3–5 (Power UB0–UB2). In the case of PWM output, it does not matter which of these pins that are used. The PWM signal is created as a differential CAN signal on pin 1 and 2. A CAN signal is said to be in a dominant state when the signal lines are separated (a dominant bit is transmitted). When the signal lines are at the same voltage level, the state is recessive. Recommended circuitry to convert CAN signals to TTL is specified in a separate document, available on request. The PWM signal is only an output signal. No messages can be sent to the sensor.

The PWM Signal

The PWM signal has a period time of 255 μ s. The rather short period is chosen since modern CAN transceivers do not allow for a longer dominant state.

The duration of the recessive state can be translated into output H₂ prediction from the sensor module. The recessive duration (pulse width) ranges from 20 to 240 μ s, which corresponds to 0 to 4.4% hydrogen. An internal error is shown as a 10 μ s pulse width.

The figure below shows the output for 0% hydrogen (pulse width of 20 μ s).

Figure 11:
Sensor Output for 0% Hydrogen (Pulse Width of 20 μs)

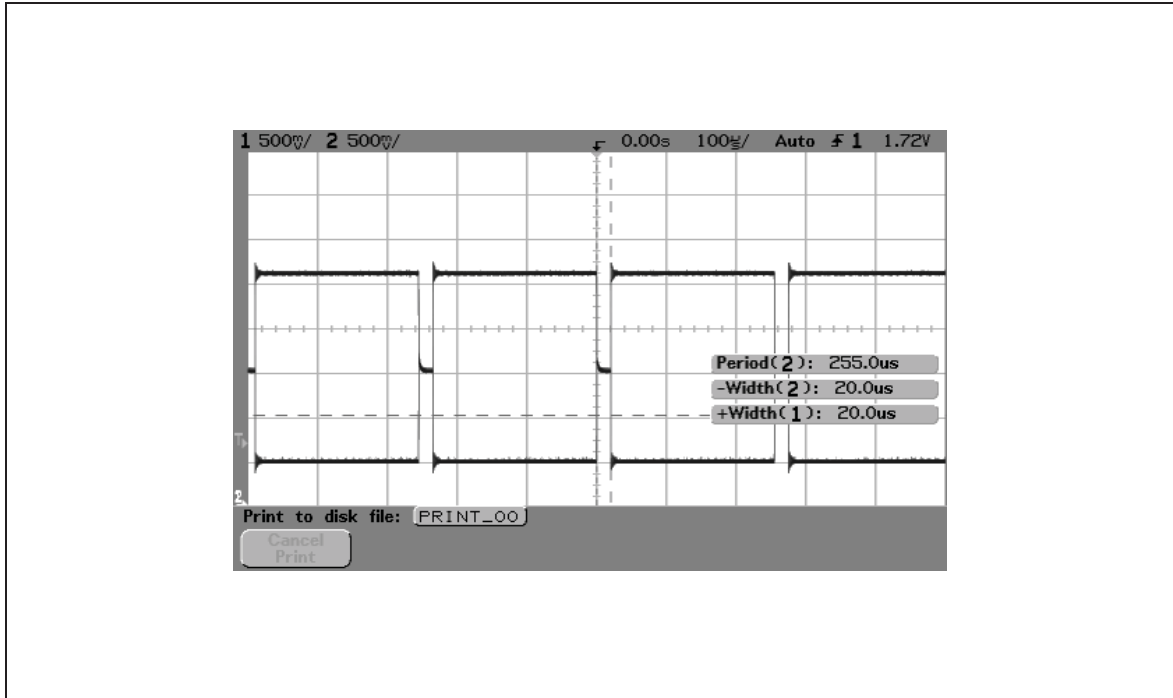

The relation between detected H₂ concentration (in ppm) and pulse width (in μs) is:

(EQ3) $H_2 = (\text{pulse width} - 20) * 200$

The figure below shows the relation between H₂ prediction and pulse width.

Figure 12:
The Relation between H₂ Prediction and Pulse Width

Pulse Width	Message Type
10 μs	Error
20 μs	0% H ₂
21 μs	0.02% H ₂
...	...
239 μs	4.38% H ₂
240 μs	4.4% H ₂

Specifications

Figure 13:
Typical Characteristics

Description	Value
Sensor Function	
Target gas	Hydrogen (H ₂)
Concentration range	0 – 4.4% H ₂ in air
Accuracy	± 3000 ppm
Resolution	200ppm
Speed of response (t ₉₀)	<2s
Speed of recovery	<10s
Cross-sensitivity	None towards HC, H ₂ S, N ₂ , CO, CO ₂ , NO _x Low humidity influence during a H ₂ event. None in air.
Start-up time ⁽¹⁾	<5s, first message after 700 ms
Expected lifetime	10 years
Safety	
Safety Integrity level	Designed for SIL2
Explosion proof	Designed for ATEX zone 2
Self test/Error handling	Yes
Electrical	
Supply voltage	9V – 16V
Supply current	75mA typical
CAN interface ⁽¹⁾	ISO 11898 Version 2.0 b
Programmable CAN ID ⁽¹⁾	on request
CAN bit rate (kbit/s) ⁽¹⁾	standard 500 (on request 125, 250)
PWM Output ⁽¹⁾	on request
Connector	A2100011199, 6-PIN Code A
Mating Connector	MQS 6-pin, AMP p/n 1-967616-1 type A
ESD/Reverse polarity	Yes

Description	Value
Environmental	
Operation temperature range	-40°C to 85°C
Storage temperature range	-50°C to 85°C
Humidity	5-95% (non-condensing)
Pressure	70-130 kPa
EMC	Automotive requirements
IP code	IP6K7
Mechanical	
Dimensions (LxWxH)	82.2x42x17.3mm
Weight	50g
Material	PBT GF30
Filter membrane	Pall SUPOR 450R, 0.45 µm.

Note(s) and/or Footnote(s):

1. These features depend on the version of HLS-442. See figure below

Figure 14:
Specification of the Different Variants of HLS-442

Description	Default	On Request		
Start-up time	<5 s			
CAN interface	Version 2.0 ISO 11898			n.a.
Programmable CAN ID	Pre-programmable on request			n.a.
CAN bit rate (kbit/s)	500	125	250	n.a.
PWM output	-			Yes

Handling Instructions

Due to the fact that the sensor element consists of a silicon chip facing the environment the following precautions have to be taken into account:

Prevent sensor from:

- Humidity (condensing conditions)
- Dropping
- Dust
- Mechanical impact, especially the entrance membrane
- Electromagnetic radiation (RF fields, high magnetic fields during storage)

Long term storage of sensors should be done in nitrogen filled ESD bags to protect the sensor.

Reference Data

Figure 15:
Concentration Measurement with H₂ Pulse Width of 2 min and Nominal Concentration 0.2%, 1.5%, 2.5% and 3.5% vol. H₂

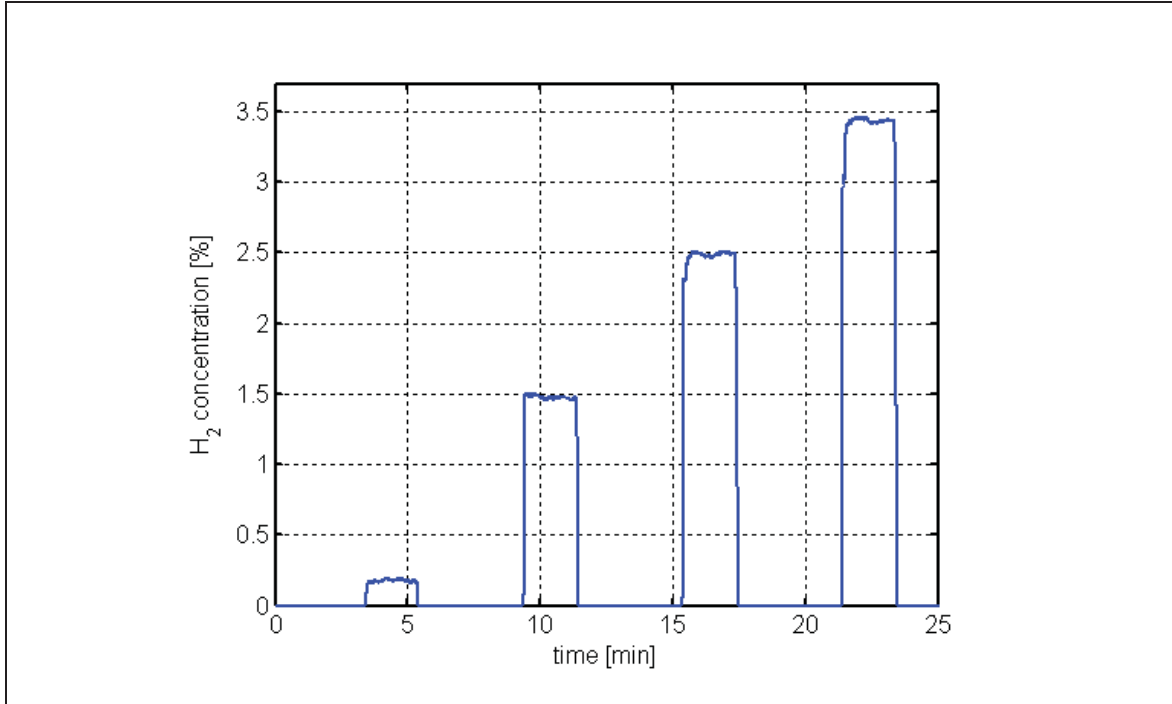
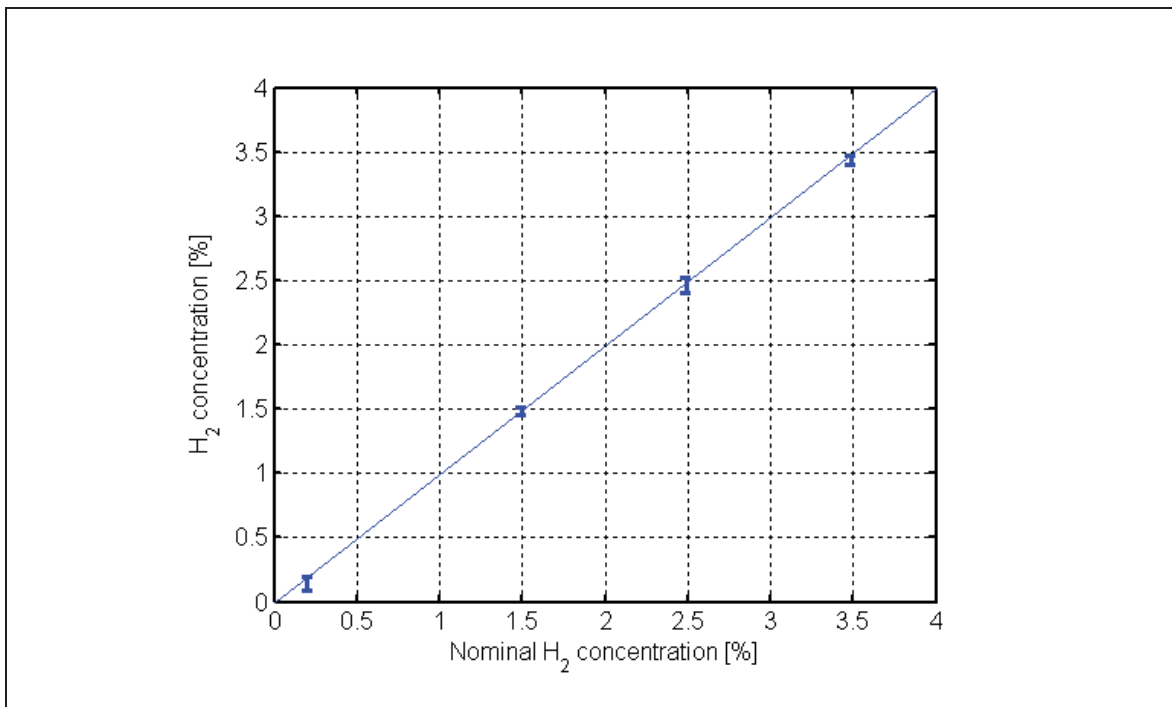

Figure 16:
Deviation of Prediction Over Nominal Concentration



Mechanical Information

Dimensions

Figure 17:
Sensor Dimensions

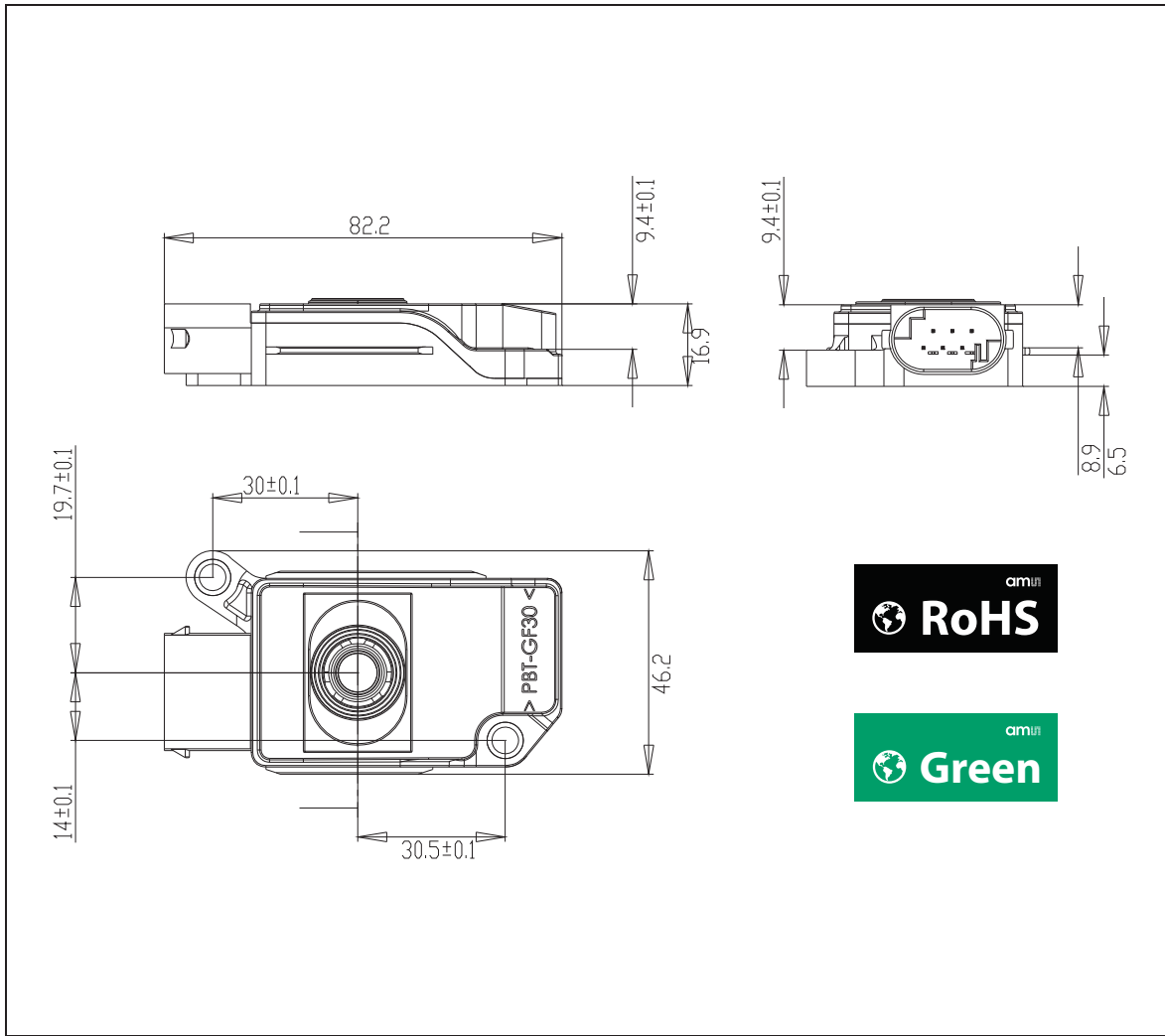

Note(s) and/or Footnote(s):

1. Dimensions are in millimeters.

Ordering & Contact Information

Figure 18:
Ordering Information

Ordering Code	Type	Delivery Form	Delivery Quantity
HLS-442	CAN (500 kbit/s) ⁽¹⁾	Individually Wrapped	Single Item

Note(s) and/or Footnote(s):

1. For availability of other variants contact **ams**.

Buy our products or get free samples online at:

www.ams.com/ICdirect

Technical Support is available at:

www.ams.com/Technical-Support

Provide feedback about this document at:

www.ams.com/Document-Feedback

For further information and requests, e-mail us at:

ams_sales@ams.com

For sales offices, distributors and representatives, please visit:

www.ams.com/contact

Headquarters

ams AG
Tobelbaderstrasse 30
8141 Unterpremstaetten
Austria, Europe

Tel: +43 (0) 3136 500 0

Website: www.ams.com

RoHS Compliant & ams Green Statement

RoHS: The term RoHS compliant means that ams AG products fully comply with current RoHS directives. Our semiconductor products do not contain any chemicals for all 6 substance categories, including the requirement that lead not exceed 0.1% by weight in homogeneous materials. Where designed to be soldered at high temperatures, RoHS compliant products are suitable for use in specified lead-free processes.

ams Green (RoHS compliant and no Sb/Br): ams Green defines that in addition to RoHS compliance, our products are free of Bromine (Br) and Antimony (Sb) based flame retardants (Br or Sb do not exceed 0.1% by weight in homogeneous material).

Important Information: The information provided in this statement represents ams AG knowledge and belief as of the date that it is provided. ams AG bases its knowledge and belief on information provided by third parties, and makes no representation or warranty as to the accuracy of such information. Efforts are underway to better integrate information from third parties. ams AG has taken and continues to take reasonable steps to provide representative and accurate information but may not have conducted destructive testing or chemical analysis on incoming materials and chemicals. ams AG and ams AG suppliers consider certain information to be proprietary, and thus CAS numbers and other limited information may not be available for release.

Copyrights & Disclaimer

Copyright ams AG, Tobelbader Strasse 30, 8141 Unterpremstaetten, Austria-Europe. Trademarks Registered. All rights reserved. The material herein may not be reproduced, adapted, merged, translated, stored, or used without the prior written consent of the copyright owner.

Devices sold by ams AG are covered by the warranty and patent indemnification provisions appearing in its General Terms of Trade. ams AG makes no warranty, express, statutory, implied, or by description regarding the information set forth herein. ams AG reserves the right to change specifications and prices at any time and without notice. Therefore, prior to designing this product into a system, it is necessary to check with ams AG for current information. This product is intended for use in commercial applications. Applications requiring extended temperature range, unusual environmental requirements, or high reliability applications, such as military, medical life-support or life-sustaining equipment are specifically not recommended without additional processing by ams AG for each application. This product is provided by ams AG "AS IS" and any express or implied warranties, including, but not limited to the implied warranties of merchantability and fitness for a particular purpose are disclaimed.

ams AG shall not be liable to recipient or any third party for any damages, including but not limited to personal injury, property damage, loss of profits, loss of use, interruption of business or indirect, special, incidental or consequential damages, of any kind, in connection with or arising out of the furnishing, performance or use of the technical data herein. No obligation or liability to recipient or any third party shall arise or flow out of ams AG rendering of technical or other services.

Document Status

Document Status	Product Status	Definition
Product Preview	Pre-Development	Information in this datasheet is based on product ideas in the planning phase of development. All specifications are design goals without any warranty and are subject to change without notice
Preliminary Datasheet	Pre-Production	Information in this datasheet is based on products in the design, validation or qualification phase of development. The performance and parameters shown in this document are preliminary without any warranty and are subject to change without notice
Datasheet	Production	Information in this datasheet is based on products in ramp-up to full production or full production which conform to specifications in accordance with the terms of ams AG standard warranty as given in the General Terms of Trade
Datasheet (discontinued)	Discontinued	Information in this datasheet is based on products which conform to specifications in accordance with the terms of ams AG standard warranty as given in the General Terms of Trade, but these products have been superseded and should not be used for new designs

Revision Information

Changes from (2014-Dec) to current revision 1-00 (2015-Mar-30)	Page
Content of Applied Sensor datasheet was updated to the latest ams design	

Note(s) and/or Footnote(s):

1. Page and figure numbers for the previous version may differ from page and figure numbers in the current revision.
2. Correction of typographical errors is not explicitly mentioned.

Content Guide

1	General Description
1	Key Benefits & Features
2	Applications
2	Block Diagram
4	Installation
5	Electrical Interface
5	Electrical Connector
6	CAN Bus Interface
6	Physical Interface
6	Bus Identification
7	Messages From the Sensor
8	<i>H2 Concentration</i>
8	Protection Value
9	<i>FE High / FE Low</i>
9	<i>CRC16</i>
9	<i>Sensor Number</i>
9	<i>Message Counter</i>
10	<i>Status</i>
10	<i>Part Number</i>
10	PWM
10	Physical Interface
10	The PWM Signal
12	Specifications
14	Handling Instructions
15	Reference Data
16	Mechanical Information
16	Dimensions
17	Ordering & Contact Information
18	RoHS Compliant & ams Green Statement
19	Copyrights & Disclaimer
20	Document Status
21	Revision Information