

**high  
performance  
needs great  
design.**

**Coverpage: AS89000 Datasheet**

Please be patient while we transfer this adapted former MAZeT document to the latest ams design.

**DATASHEET**

AS89000

**Multi-channel programmable gain transimpedance amplifier**

QSOP16

Order No.: 305100002

Status: preliminary

**INTRODUCTION**

The AS89000-devices are a family of integrated circuits of **programmable gain transimpedance amplifiers** with **4 channels** per IC (more custom specific, on request).

The AS89000-devices are mainly used for **signal conditioning of sensors with current outputs**. They are especially suitable for connection of photodiodes of **array and row sensors**. The possibility to **adjust the transimpedance in 8 stages** is a special feature.

The adjustment is made by programming three pins and is valid for all channels together.

The device packages (naked chip on request) are RoHS conform and optimized for **COB- mounting and SMD**.

**1 BLOCK DIAGRAM**

Figure 1: Block diagram

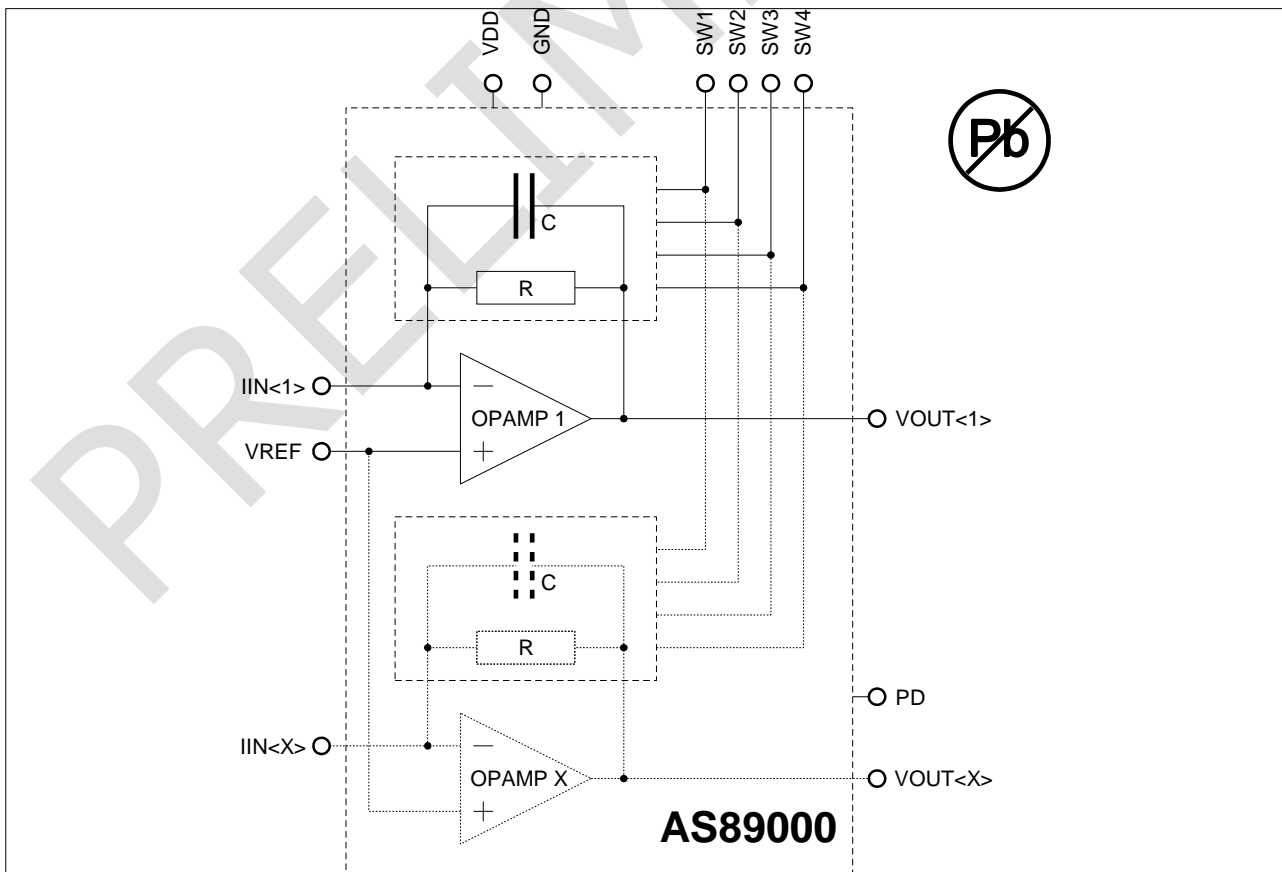

<b>INTRODUCTION .....</b>	<b>1</b>
<b>1 BLOCK DIAGRAM .....</b>	<b>1</b>
<b>2 DESCRIPTION OF INTERFACE.....</b>	<b>3</b>
2.1 Pin Assignment.....	3
2.2 Adjustment of Transimpedance.....	3
2.3 Switchable Frequency Range.....	3
2.4 Power Down Mode.....	3
<b>3 DESCRIPTION OF FUNCTION .....</b>	<b>4</b>
<b>4 ELECTRICAL CHARACTERISTICS.....</b>	<b>4</b>
4.1 Maximum Conditions .....	4
4.2 Operating Conditions .....	4
4.3 AC/DC-Characteristics .....	5
<b>5 PACKAGES.....</b>	<b>7</b>
5.1 Shape & Dimensions.....	7
5.2 Pin Configuration .....	8
5.3 Soldering Information.....	9
<b>6 APPLICATIONS.....</b>	<b>10</b>
6.1 Connection of ams Sensors Germany Color Sensor.....	10
6.2 Temperature Compensation of AS89000 via Reference Method .....	10
6.3 Output Signals $V_{OUT}$ .....	11
<b>ORDERING INFORMATION.....</b>	<b>12</b>
<b>LEGAL NOTES AND WARNINGS .....</b>	<b>13</b>

## 2 DESCRIPTION OF INTERFACE

### 2.1 Pin Assignment

Table 1: Pin assignment

SIGNAL NAME	TYP	A/D <sup>a</sup>	FUNCTION
VDD	input	a/d	power supply
GND	input	a/d	ground
VREF	input	a	reference voltage
SW1	input	d	input 1 for adjustment of transimpedance of AS89000-amplifier (pull
SW2	input	d	input 2 for adjustment of transimpedance of AS89000-amplifier (pull
SW3	input	d	input 3 for adjustment of transimpedance of AS89000-amplifier (pull
SW4	input	d	switchable frequency range depended on input capacitance of the photo-sensor (pull down)
PD	input	d	power down mode (pull down)
IIN<X>	input	a	analog current input of amplifier X
VOUT<X>	output	a	analog voltage output of amplifier X

<sup>a)</sup> analog or digital

### 2.2 Adjustment of Transimpedance

Table 2: Adjustment of Transimpedance

SETTINGS OF DIGITAL INPUTS			
SW1	SW2	SW3	TRANSIMPEDANCE R
VDD	VDD	VDD	20 M $\Omega$ – <b>stage 1</b>
GND	VDD	VDD	10 M $\Omega$ – <b>stage 2</b>
GND	VDD	GND	5 M $\Omega$ – <b>stage 3</b>
VDD	GND	VDD	2 M $\Omega$ – <b>stage 4</b>
GND	GND	VDD	1 M $\Omega$ – <b>stage 5</b>
VDD	GND	GND	500 k $\Omega$ – <b>stage 6</b>
VDD	VDD	GND	100 k $\Omega$ – <b>stage 7</b>
GND	GND	GND	25 k $\Omega$ <sup>b</sup> – <b>stage 8</b>

<sup>b)</sup> default by pull down

### 2.3 Switchable Frequency Range

Table 3: Switchable Frequency Range

SETTINGS OF DIGITAL INPUT	
SW4	ALLOWED CAPACITANCE OF PHOTO-SENSOR
VDD	< 5 pF
GND	< 80 pF <sup>c</sup>

<sup>c)</sup> default by pull down

### 2.4 Power Down Mode

Table 4: Power Down Mode

SETTINGS OF DIGITAL INPUT	
PD	BIAS CURRENT OF THE IC
VDD	< 8 $\mu$ A
GND	typical <sup>d</sup>

<sup>d)</sup> default by pull down

### 3 DESCRIPTION OF FUNCTION

The AS89000-devices are programmable gain transimpedance amplifiers<sup>1</sup> with different numbers of channels (AS89000 – 4 channels). There is one transimpedance amplifier per channel between a current input  $I_{IN}<X>$  and a voltage output<sup>2</sup>  $V_{OUT}<X>$ . Its transimpedance is selectable in 8 stages. This adjustment can be effected by setting of digital inputs SW1, SW3 and SW4 and is valid for all channels simultaneously (chapter 2.2).

Also simultaneously valid for all channels is a compensation of the input capacitance of photo-sensors for two possible frequency ranges (switchable by SW4, chapter 2.3).

The pins SW1, SW2, SW3 and SW4 are pull down inputs.

The second input of all transimpedance amplifiers is used for a common supply by a reference voltage necessarily fed in through the pin  $V_{REF}$ .

All channels are compensated for an external input capacitance of the photo-sensor of smaller than 80 pF (SW4 = GND). The power supply for the AS89000-devices is typical 3 V to 5 V between VDD and GND.

The power down mode is adjusted by PD = VDD and switches off the functionality. In that case it must be pointed out that the transimpedance resistor of stage 8 is between the particular inputs and outputs. The amplifiers are switched off (tri-state).

### 4 ELECTRICAL CHARACTERISTICS

#### 4.1 Maximum Conditions

Violations of absolute maximum conditions are not allowed under any circumstances, otherwise the IC can be destroyed.

All voltages are referenced to GND = 0 V.

PARAMETER	NAME	MIN	MAX	UNIT
power supply	VDD	0.3	7.0	V
input and output voltages	⇒ IC-pinning	0.3	VDD+0.3	V
power dissipation	$P_{OP}$		0.025	W
operating temperature	$T_{OP}$	-40	125	°C
storage temperature	$T_{STG}$	-55	155	°C
weight	m		0,08	g

#### 4.2 Operating Conditions

All voltages are referenced to GND = 0 V.

Table 5: Operating Conditions

PARAMETER	NAME	MIN	TYP	MAX	UNIT	CONDITION
supply voltage	VDD	2.7	3 to 5	5.5	V	
bias current AS89000	$I(VDD)$		2.5	4.0	mA	27°C, VDD=5.5 V

<sup>1</sup> work as inverted amplifiers

<sup>2</sup>  $V_{OUT} = V_{REF} - I_{IN} * R$

PARAMETER	NAME	MIN	TYP	MAX	UNIT	CONDITION
bias current AS89000	I(VDD)			8	μA	PD=VDD
operating temperature	T <sub>OP</sub>	-40	27	125	°C	
input high level	V <sub>IH</sub>	0.7-VDD		VDD+0.3	V	
input low level	V <sub>IL</sub>	-0.3		0.8	V	
reference voltage	VREF	0.4		VDD-0.4	V	

### 4.3 AC/DC-Characteristics

Unless otherwise specified the data in this table is valid for T<sub>OP</sub> = 27°C and VDD = 5 V.

All voltages are referenced to GND = 0 V.

Table 6: AC/DC-Characteristics

PARAMETER	NAME	MIN	TYP	MAX	UNIT	CONDITION
			0.025		μA	stage 1
			0.05		μA	stage 2
			0.1		μA	stage 3
			0.25		μA	stage 4
			0.5		μA	stage 5
			1		μA	stage 6
			5		μA	stage 7
			20		μA	stage 8
		14000	20000	26700	kΩ	stage 1
		7000	10000	13350	kΩ	stage 2
		3500	5000	6700	kΩ	stage 3
		1400	2000	2670	kΩ	stage 4
		700	1000	1335	kΩ	stage 5
		350	500	670	kΩ	stage 6
		70	100	133	kΩ	stage 7
		17	25	34	kΩ	stage 8
		4	6	16	kHz	stage 1, T <sub>OP</sub> (4.2)
		7	11	28	kHz	stage 2, T <sub>OP</sub> (4.2)
		11	16	42	kHz	stage 3, T <sub>OP</sub> (4.2)
		18	26	66	kHz	stage 4, T <sub>OP</sub> (4.2)
		25	35	95	kHz	stage 5, T <sub>OP</sub> (4.2)
		35	50	130	kHz	stage 6, T <sub>OP</sub> (4.2)
		80	120	280	kHz	stage 7, T <sub>OP</sub> (4.2)
		160	300	580	kHz	stage 8, T <sub>OP</sub> (4.2)
		4	6	16	kHz	stage 1, T <sub>OP</sub> (4.2)
		7	11	28	kHz	stage 2, T <sub>OP</sub> (4.2)

PARAMETER	NAME	MIN	TYP	MAX	UNIT	CONDITION
signal frequency at input SW4 = VDD ( $C_{\text{PHOTO-SENSOR}} < 5\text{pF}$ )	$f_{3\text{dB}}$	14	21	45	kHz	stage 3, $T_{\text{OP}} (4.2)$
		35	54	130	kHz	stage 4, $T_{\text{OP}} (4.2)$
		70	110	260	kHz	stage 5, $T_{\text{OP}} (4.2)$
		100	160	360	kHz	stage 6, $T_{\text{OP}} (4.2)$
		260	380	780	kHz	stage 7, $T_{\text{OP}} (4.2)$
		500	800	1700	kHz	stage 8, $T_{\text{OP}} (4.2)$
temperature coefficient of the feedback resistor <sup>3</sup>	$TC_R$		-3300		ppm/K	
offset voltage	$V_{\text{OFF}}^4$	-10		10	mV	$T_{\text{OP}} (4.2)$
capacitive load at $V_{\text{OUT}}\langle X \rangle$	$C_{\text{LOAD}}$			50	pF	$I_{\text{LOAD}} < 0.5 \text{ mA}$ per output
pull down current SW1, SW2, SW3, SW4, PD	$I_{\text{PDPAD}}$			200	$\mu\text{A}$	digital inputs
input capacitance of external connected photo-sensors	$C_{\text{PHOTO-SENSOR}}$			80	pF	per input SW4 = GND
input capacitance of external connected photo-sensors	$C_{\text{PHOTO-SENSOR}}$			5	pF	per input SW4 = VDD
tolerance of the feedback resistors between the four channels	$TOL_R^5$	1		10	%	DC input current; for all stages

<sup>3</sup> see also chapter 6.2

<sup>4</sup>  $V_{\text{OFF}} = V_{\text{OUT}}\langle X \rangle - V_{\text{REF}}$ ; results from input offset voltage and input leakage current

<sup>5</sup> up to max. 1% available on request

## 5 PACKAGES

### 5.1 Shape & Dimensions

Figure 2: Shape & Dimensions

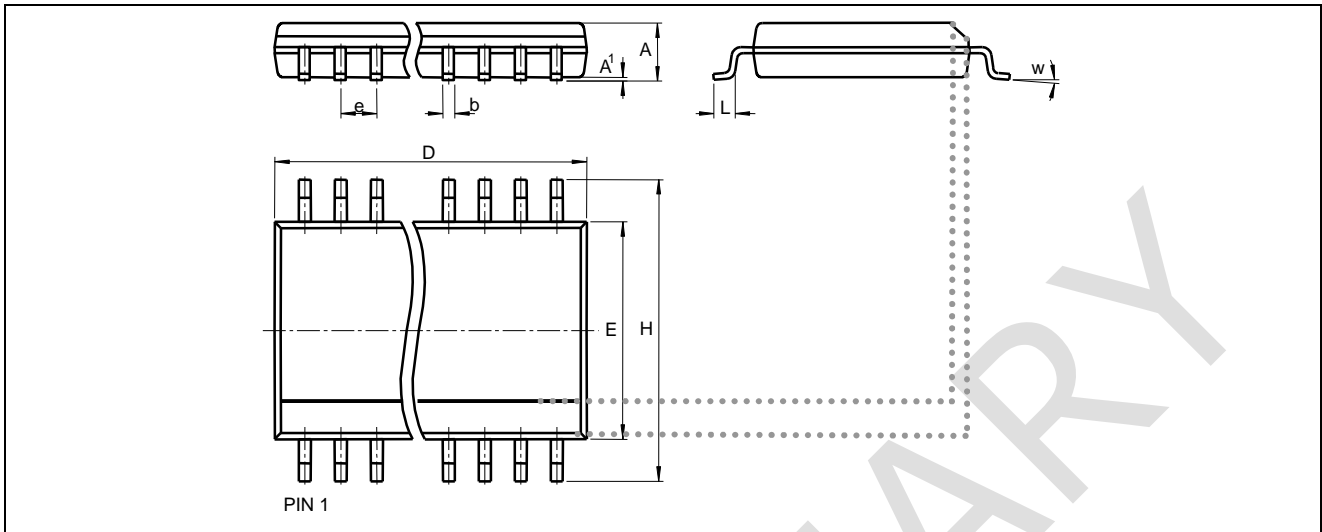

1) tapered edge

As shown in the figure PIN 1 is located on the bottom of the left corner of the outline.

Table 7: dimensions – mm

TYP	PACKAGE	D	E	H	A	A1	e	b	L	w
AS89000	QSOP16	4.90	3.80	6.00	1.75	0.15	0.635	0.38	0.72	4°



### 5.2 Pin Configuration

Figure 3: Pin Configuration

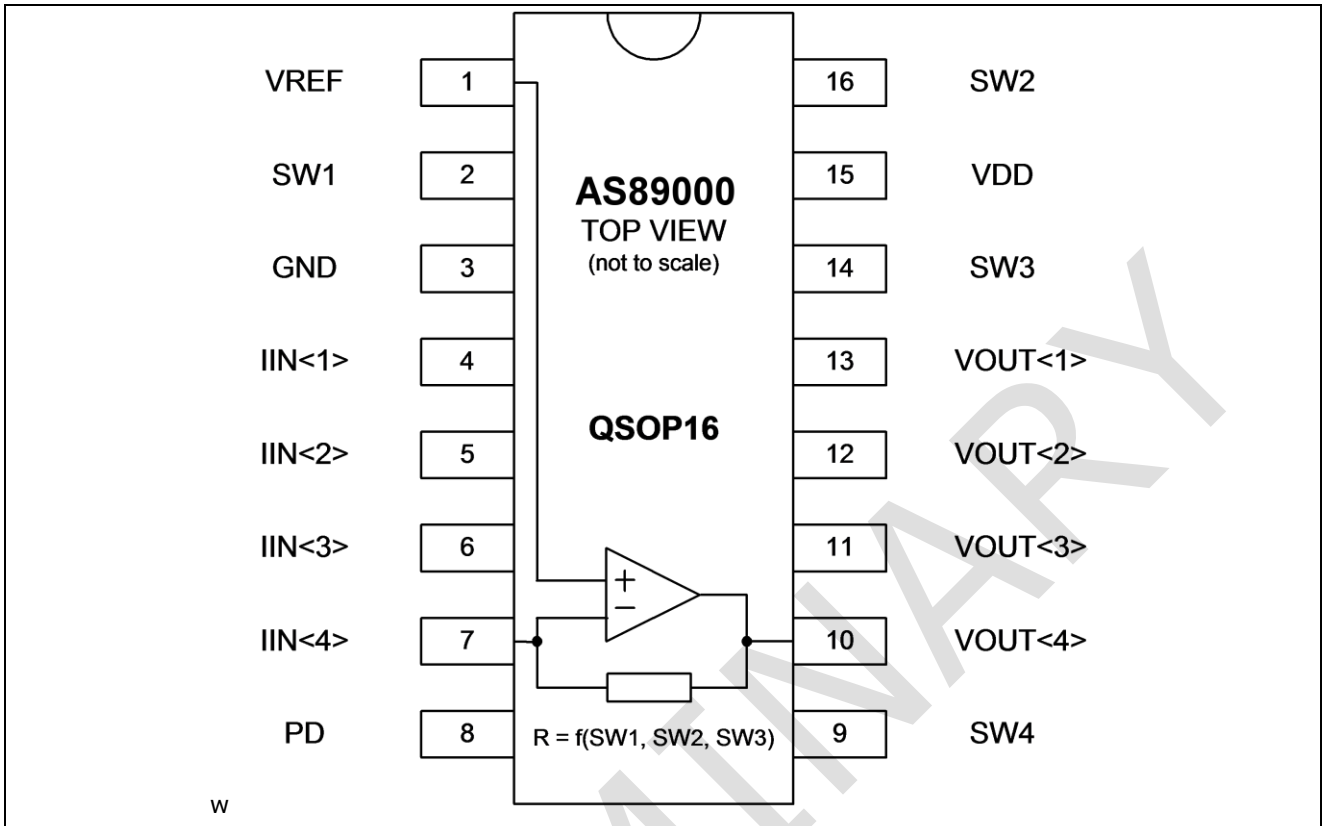

### 5.3 Soldering Information

The solder reflow profile should fulfil the specifications for the reflow profile parameters given in Table 8. These parameters follow the IPC/JEDEC standard J-STD-020D.1. The temperature should be measured at the top of the package.

Figure 4: Recommended reflow profile

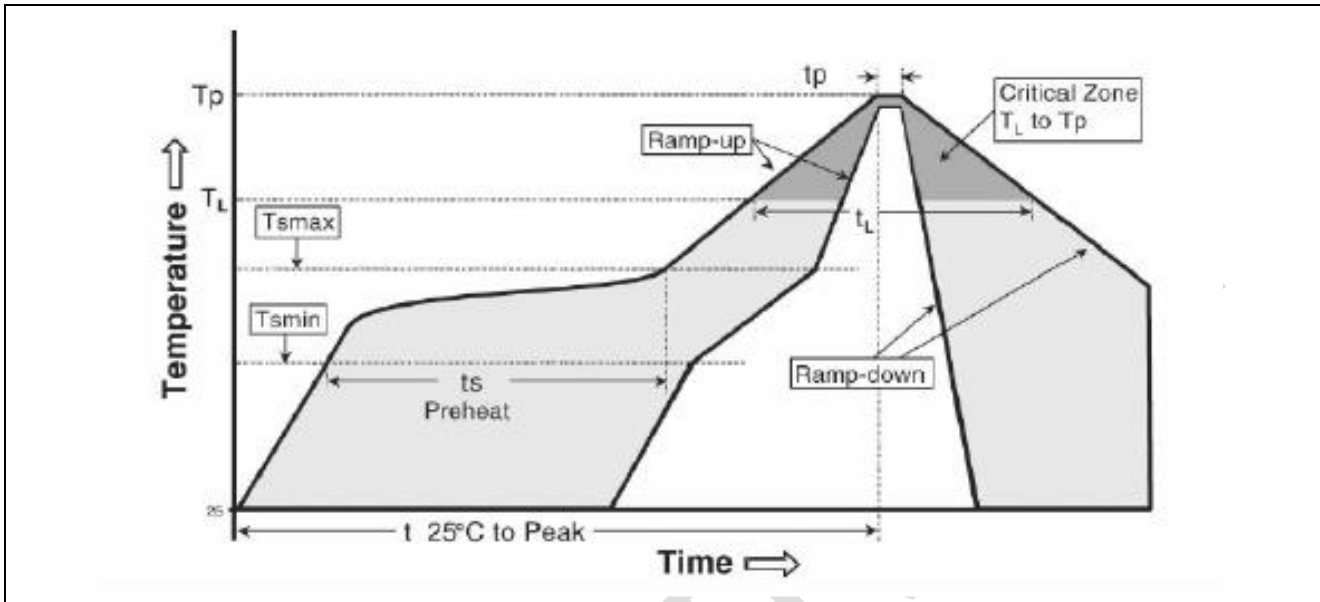

Table 8: Reflow profile parameters

PROFILE PARAMETER	ASSEMBLY, CONVECTION
ramp-up rate (T <sub>smax</sub> to T <sub>p</sub> )	2-3°C/second
preheat temperature (T <sub>smin</sub> to T <sub>smax</sub> )	150°C to 200°C
preheat time (t <sub>s</sub> )	60 – 120 seconds
time above T <sub>L</sub> , 217°C (t <sub>L</sub> )	60 – 150 seconds
peak temperature (T <sub>p</sub> )	260°C
time within 5°C of peak temperature (t <sub>p</sub> )	20 – 40 seconds
ramp-down rate	6°C/second
time 25°C to peak temperature	8 minutes max.

## 6 APPLICATIONS

### 6.1 Connection of ams Sensors Germany Color Sensor

Figure 5: Circuit for the conversion of sensor's photo current to an equivalent voltage by using the amplifier AS89000

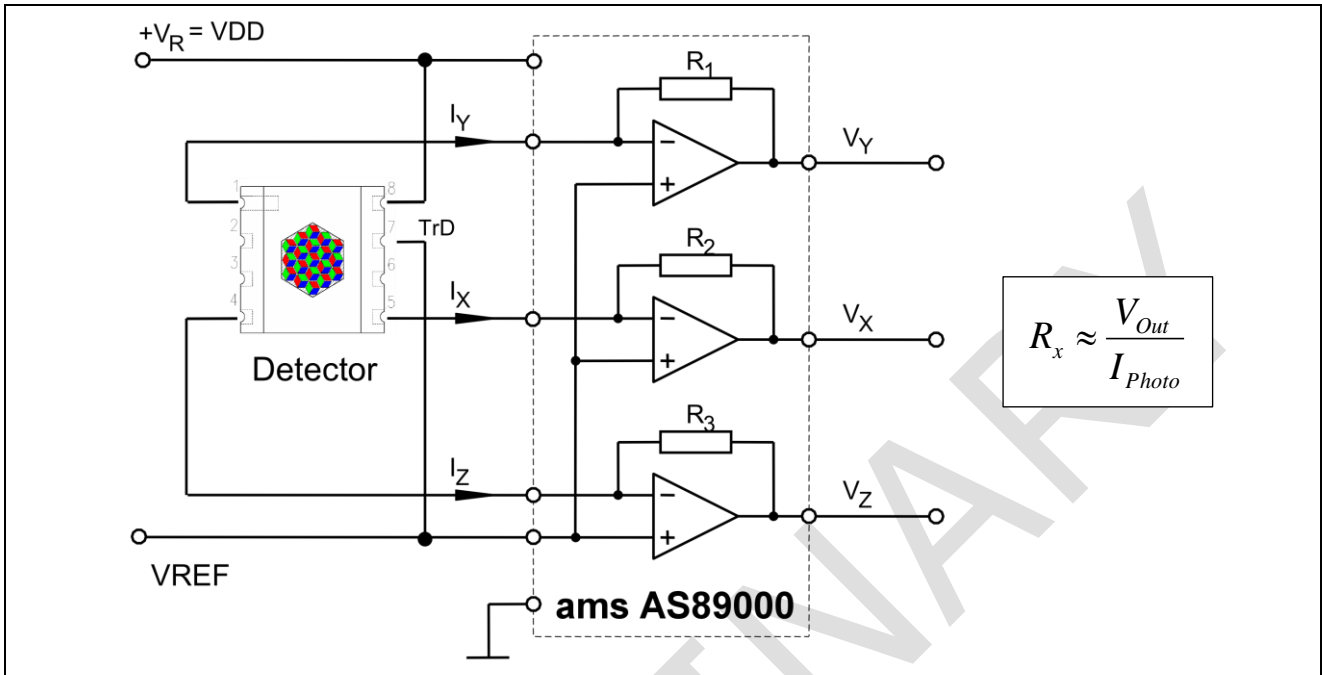

Opposite figure shows a circuit for the conversion of sensor's photo current to an equivalent voltage by using the amplifier AS89000. The resulted voltage can be processed e.g. with an ADC. By the selection of suitable resistors/amplifying stage the output voltage range can be adjusted to the photo current value by programming the pin-programmable transimpedance amplifier AS89000.

### 6.2 Temperature Compensation of AS89000 via Reference Method

The following description shows a possible approach for reduction the temperature dependency of amplifier via reference channel (use the 4<sup>th</sup> channel of AS89000).

Figure 6: Possible approach for reduction the temperature dependency of amplifier via reference channel

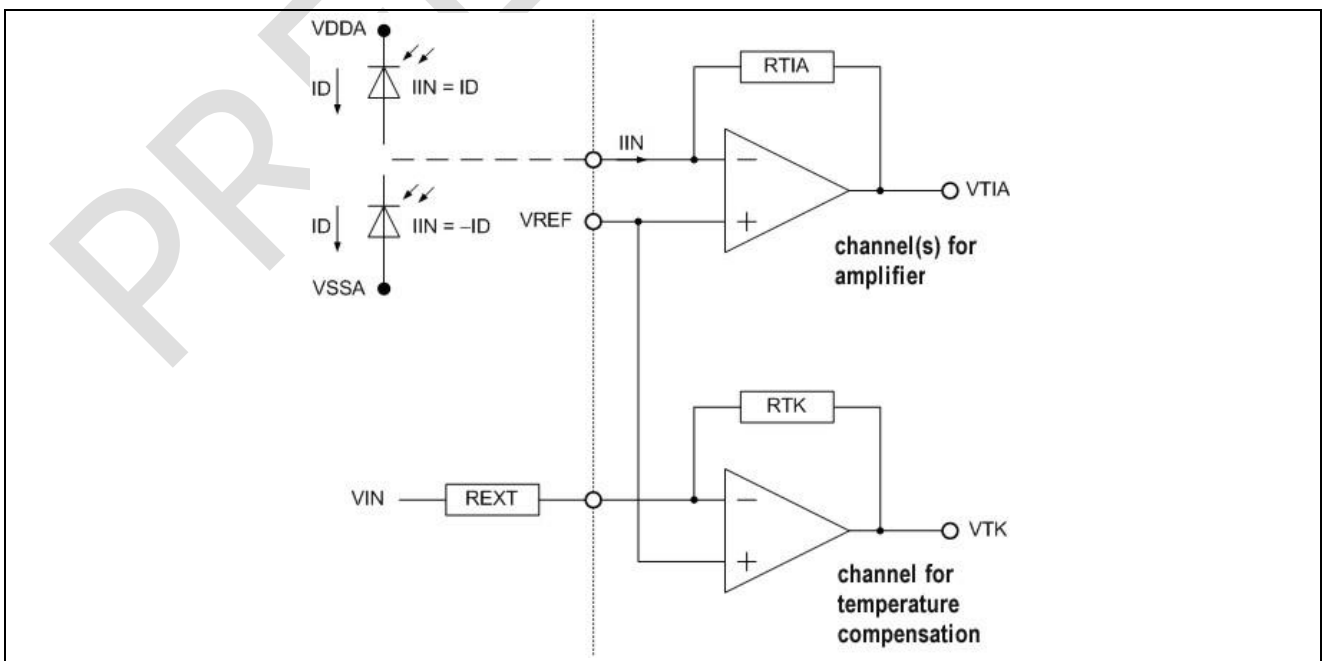

The input of the reference channel is connected with an external resistor that will load with an input voltage which is different to VREF.

The output voltage of the measuring channel is explained in the coming formula:

$$(1) VTIA(T) = VREF(T) - IIN * RTIA(T)$$

IIN is the input current, which is supplied by the external sensor. The output voltage of the channel for the temperature compensation is defined:

$$(2) VTK(T) = VREF(T) - \frac{VIN(T) - VREF(T)}{REXT(T)} * RTK(T)$$

The following voltages will calculate for temperature compensation with a resistor.

$$(3) \Delta VTIA(T) = VREF(T) - VTIA(T)$$

$$(4) \Delta VTK(T) = VREF(T) - VTK(T)$$

For example the voltage  $\Delta VTK(T_0)$  will detect during the initialization of the system. The value is equivalent to a constant for the temperature  $T_0$ , which prevailed at the time of initialization. All further measurements will calibrate by this value.

$$(5) \Delta VTIA_{korrigiert}(T) = \Delta VTIA(T) * \frac{\Delta VTK(T_0)}{\Delta VTK(T)}$$

All variables of the channel for temperature compensation are affected by temperature effects. Therefore there is an additional coefficient necessary. That coefficient should be highly reduced opposite to the named above value of the RTIA (typical -3300 ppm/K).

$$(6) TK = TK(REXT) - \frac{VIN}{VIN - VREF} * TK(VIN) + \frac{VREF}{VIN - VREF} * TK(VREF)$$

„TK(REXT)“ is the temperature coefficient of the external resistor, „TK(VIN)“ is the temperature coefficient of the input voltage and „TK(VREF)“ is the temperature coefficient of the reference voltage.

Please consider the following interrelationship by the choice of resistors REXT and RTK in term of the selected voltages VIN and VREF (values from (2) and (4)).

$$(7) \frac{REXT}{RTK} > \left| \frac{VIN}{VREF} - 1 \right|$$

The adherence of this non-equation ensures, that the voltage VTK is located in the working range. That means the amplifier of the channel for temperature compensation doesn't go into saturation.

Furthermore you can calculate the absolute value of the transimpedance resistor RTK for a certain actual existing temperature.

$$(8) RTK(T) = REXT(T) * \frac{VREF(T) - VTK(T)}{VIN(T) - VREF(T)}$$

### 6.3 Output Signals V<sub>OUT</sub>

AS89000 works by the principle of a connected op-amp:

$$V_{OUT} = V_{REF} - I_{IN} * R \quad \{\text{limited by GROUND ...VREF}\}$$

$$I_{IN} = 0 \quad \rightarrow \quad V_{OUT} = V_{REF}$$

$$I_{IN} = \text{max.} \quad \rightarrow \quad V_{OUT} = 0$$

**ORDERING INFORMATION**

NAME	STATUS	PACKAGE	ARTICLE
AS89000	Series	QSOP16	305100002

PRELIMINARY

---

For more information please contact:

**ams Sensors Germany GmbH:**

Göschwitzer Straße 32  
07745 JENA | GERMANY  
Phone: +49 3641 2809-0  
Fax: +49 3641 2809-12  
sales-europe@ams.com  
www.ams.com

## LEGAL NOTES AND WARNINGS



Failure to comply with these instructions could result in death or serious injury.

Misuse of documentation – The information contained in this document is the property of ams Sensors Germany. Photocopying or otherwise reproducing any part of the catalog, whether electronically or mechanically is prohibited, except where the express permission of ams Sensors Germany GmbH has been obtained. In general, all company and brand names, as well as the names of individual products, are protected by brand, patent or product law.

State of document - The information provided in this document is for reference only. Do not use this document as product installation guide since products can be under development to improve performance or any other purpose. Before you start any development or place an order please contact your supplier or ams Sensors Germany for the latest version of this document. ams Sensors Germany explicitly reserves the right to make technical changes to information described in the document.

Information and Disclaimer – The information provided in this document is based on the knowledge of the ams Sensors Germany GmbH as of the date of publication. The ams Sensors Germany GmbH cannot give warranty regarding the accuracy of information provided by third parties. ams Sensors Germany may not have conducted testing or chemical analysis on all incoming material or chemicals. ams Sensors Germany GmbH performs and continues to perform reasonable measures to provide the most accurate data at the given time. Additional efforts to integrate information provided by third parties are performed and continue to be performed. Certain supplier information may be proprietary or limited and not available at release.



**Personal Injury:** All products are conform to the specifications in accordance with the terms and conditions of ams Sensors Germanys standard warranty. Production processing does not necessarily include testing of all parameters.



RoHS Directive 2011/65/EU /REACH INFORMATION - RoHS compliance and PB free: The products of ams Sensors Germany fully comply with the current RoHS-directives. Our semiconductor products do not contain any of the six substance chemical categories, for example including the restriction on lead usage (lead weight may not exceed 0.1% in homogeneous materials). RoHS compliant products are suitable for the usage in lead-free specified processes, when designed to be soldered at high temperatures.

REACH information: ams Sensors Germany products do not contain any of the latest REACH Substances of Very High Concern (SVHC) regarding the Europe Union (EU) Regulation 1907/2006. The latest 155 substances restricted per the REACH Regulation were last updated on June 16, 2014. Please refer to the following for the most current candidate list of substances: <http://echa.europa.eu/candidate-list-table>.



ams Sensors Germany solutions are not designed or intended for use in critical applications, in which the failures or malfunctions of the product may result in personal injury or death. Use of ams Sensors Germany products in life support systems is expressly unauthorized and any use by customer is completely at their own risk. In the case of a restricted use of the product described here, an application of the product outside of this limitation is at your own risk.

Warranty disclaimer – The warranty expressed herein shall be in lieu of any other warranties, expressed or implied, including, without limitation, any implied warranties or conditions of merchantability and fitness for a particular purpose., which are expressly disclaimed, and is in lieu of any and all other obligations or liability on supplier's part- For the avoidance of doubt, supplier shall not be liable for any special, incidental, indirect or consequential loss or damage, including loss of revenue or profit, of any kind of nature, arising at any time, from any cause whatsoever resulting from the use or operation of the products or any breach of this limited warranty.

Legal liability - ams Sensors Germany assumes no responsibility for the use of any foreign products or circuits described in this document or customer product design, conveys no license, either expressed or implied, under any patent or other right, and makes no representation that the foreign circuits are free of patent infringement. ams Sensors Germany further makes no claim as to the suitability of its products for any particular purpose, nor does ams Sensors Germany assume any liability arising out of the use of any product or circuit, and specifically disclaims any and all liability, including without limitation consequential or incidental damages.



**ESD Warning:** Sensor handling precautions should be observed to avoid static discharge.



**WEEE Disposal:** - The product should be disposed in to according the Directive 2002/96 / EC of the European Council on Waste Electrical and Electronic Equipment [WEEE] and the German electoral law [ElektroG] of 16 March 2005. Please contact our technical support if you need more details.