

AS1701/06

Demoboard Application Note

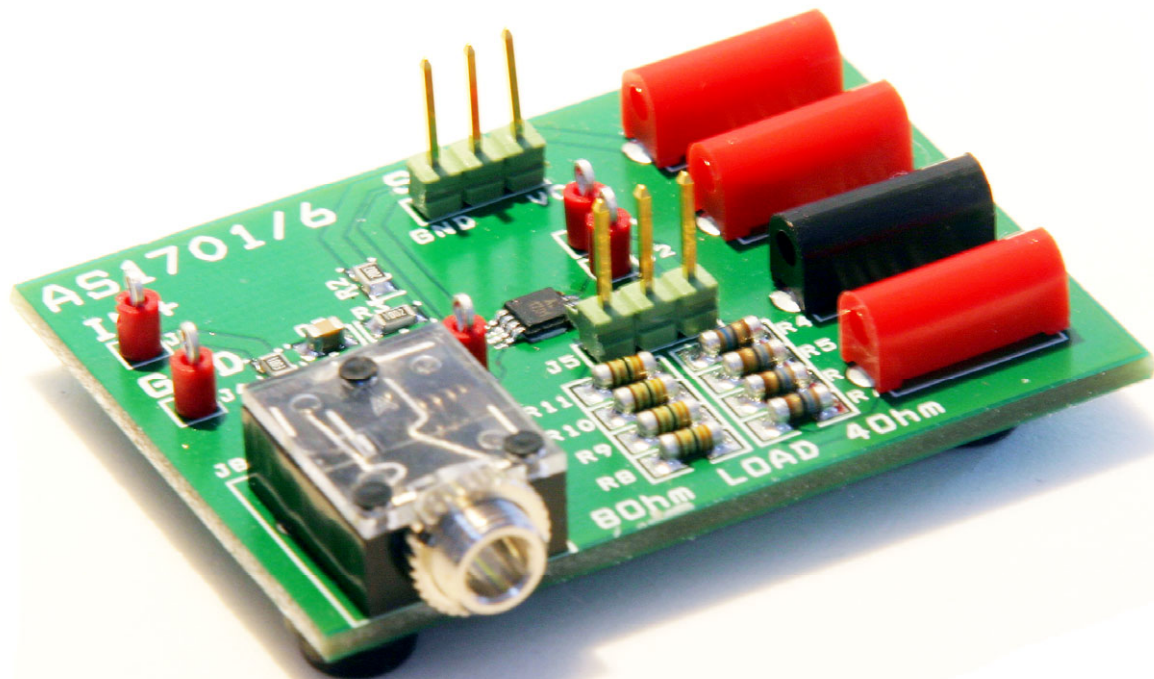

General Description

Input/Output Description

Table 1: Input/Output Description

Mark	Connector	Description
A	J6	Input Connectors for single ended signal source.
C	VCC	Power Supply Connectors for VCC and GND.
D	GND	
B	OUT+	Outputs Connectors.
E	OUT-	

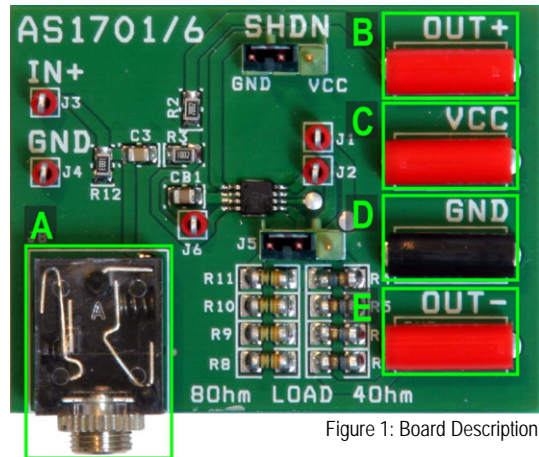





Figure 1: Board Description

Jumper Description

Table 2: Jumper Description

Mark	Jumper	Description	Set	Not Set	
F	SHDN	Shutdown	 AS1701, to GND: Normal operation.	 AS1706, to Vcc: Normal operation.	Not recommended
G	J5	Output Impedance	 Load = 80 Ohm	 Load = 40 Ohm	Load = 0 Ohm

Measurement Points Description

Table 3: Measurement Points Description

Mark	Pin	Description
H	J3	IN+ of Input Signal
I	J4	Ground of Input Signal
J	J6	Ground BIAS
K	J1	OUT+
L	J2	OUT-

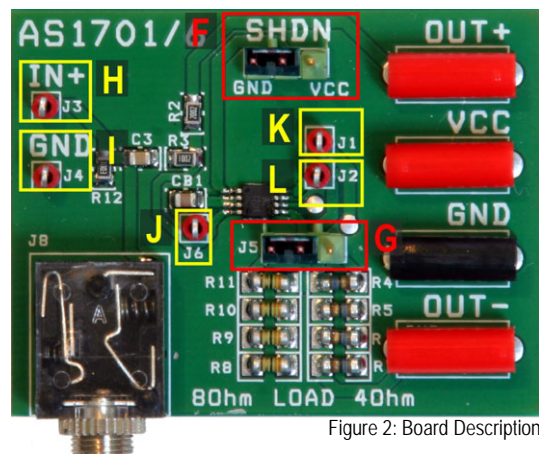

Figure 2: Board Description

Input Signal Connector

Use a mono 1/8" (3.5mm) mono jack (figure 3) to connect the input signal with the input connector (A). The head of the mono jack should be connected to IN+ of the signal while the shell is connected to ground.



Figure 3: Mono Jack

Circuit

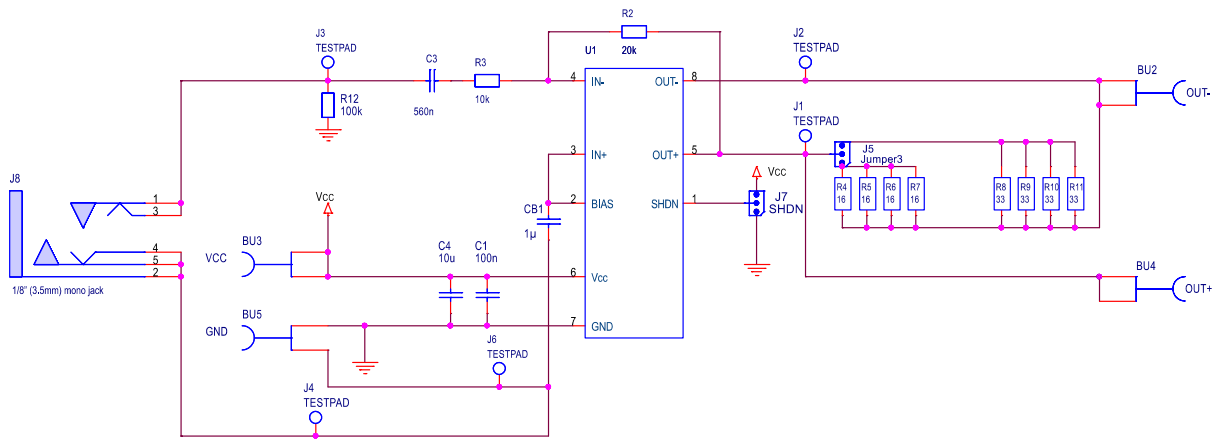

Starting Up

Soldered Chip

The AS1701/06 demo board is designed to work with the AS1701, and the AS1706. Before using the Demoboard please make sure which chip is on the board and set the Jumpers appropriate if necessary. The marking of the chip can be found printed on the IC soldered on the board.

Per default an AS1701 is mounted on the Demoboard

Two different Jumper settings are necessary, one for the AS1701 and another for the AS1706.

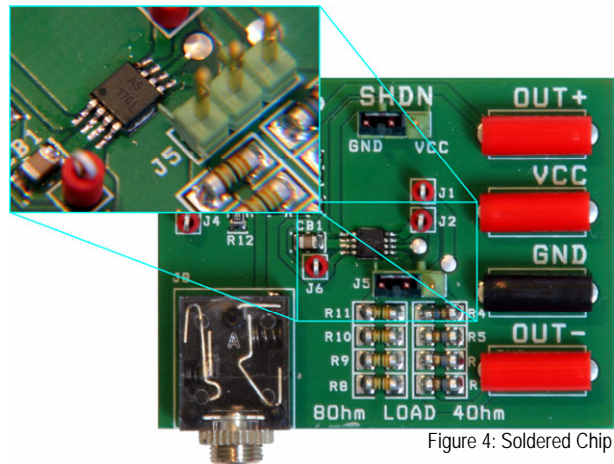

Figure 4: Soldered Chip

If an AS1701 is soldered, set the following jumpers:

Table 4: Jumper settings AS1701

Mark	Jumper	Description	Jumper Set	Value
F	SHDN	Normal operation	<input type="checkbox"/> SET	GND
	SHDN	Shutdown Mode	<input checked="" type="checkbox"/> SET	Vcc
G	J5	Output Impedance	OPTIONAL (3 values possible)	Load = 0 / 4 / 8Ohm

If an AS1706 is soldered, set the following jumpers:

Table 5: Jumper settings AS1706

Mark	Jumper	Description	Jumper Set	Value
F	SHDN	Normal operation	<input checked="" type="checkbox"/> SET	Vcc
	SHDN	Shutdown Mode	<input type="checkbox"/> SET	GND
G	J5	Output Impedance	OPTIONAL (3 values possible)	Load = 0 / 4 / 8Ohm

Operational sequence

1. If not present get the datasheet for the AS1701/06 from www.austriamicrosystems.com. Drive the IC on the Demoboard only with the recommended settings and values as described in the datasheet.
2. Make sure which IC is soldered on the Demoboard.
3. Set Jumper as described above.
 - Choose an output impedance.
4. Connect a 2.7 to 5.5V power supply (VDD and GND).
5. Connect a **single ended** signal source. 
6. Measure on the measuring points J1(OUT+) and J2(OUT-) and J15(BIAS-GND).

Note: It's possible to connect headphones or speakers (4Ohm or 8Ohm Impedance) to the outputs. Make sure the onboard Output Impedance is set to 0Ohm with removing Jumper J5 (G).

Have fun using the Demoboard. If there are questions do not hesitate to contact us. See contact information below.

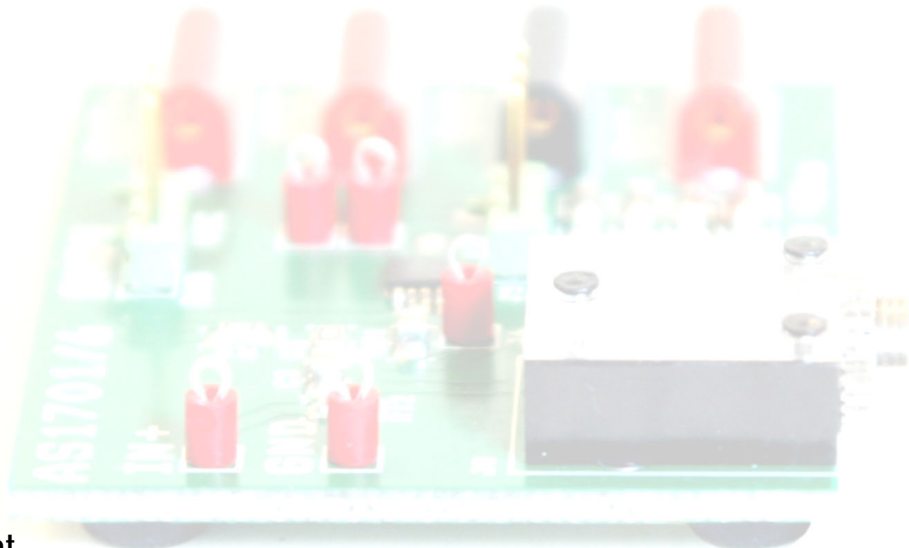

Copyright

Copyright © 2006 austriamicrosystems. Trademarks registered ®. All rights reserved. The material herein may not be reproduced, adapted, merged, translated, stored, or used without the prior written consent of the copyright owner. To the best of its knowledge, austriamicrosystems asserts that the information contained in this publication is accurate and correct.

Contact Information

Headquarters:

austriamicrosystems AG
Standard Linear
A 8141 Schloss Premstätten, Austria
T. +43 (0) 3136 500 0
F. +43 (0) 3136 5692
info@austriamicrosystems.com

For Sales Offices, Distributors and Representatives, please visit: www.austriamicrosystems.com