

AS1325

Evaluation Board Application Note

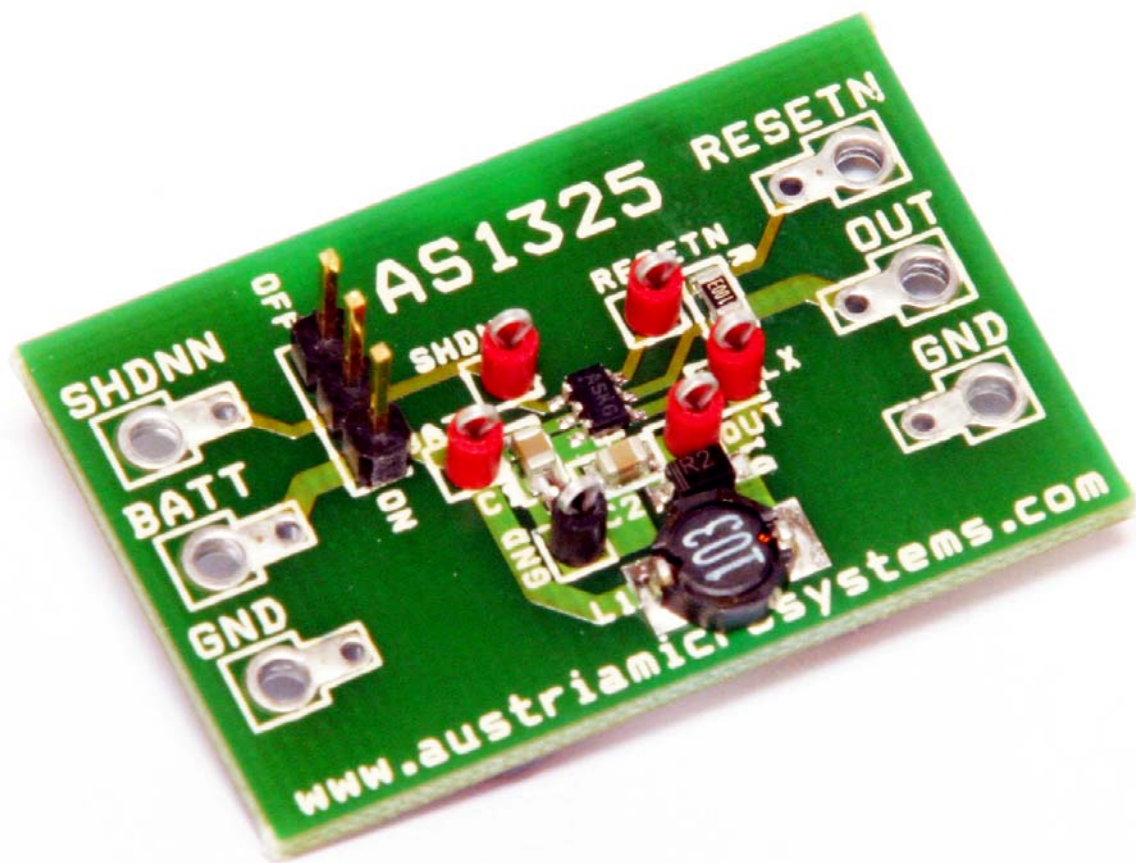

General Description

Board Description

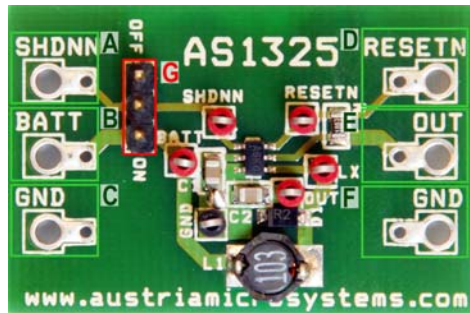

Figure 1: Board Description

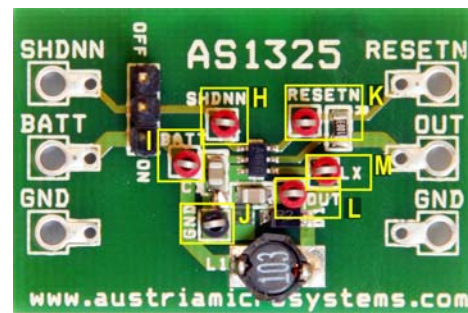



Figure 2: Board Description

Connector Description

Label	Name	Description	Info
A	SHDNN	Active-Low Logic Shutdown Input	
B	BATT	Power Supply Connectors for VBATT and Ground.	+1.5V to VOUT
C	GND		
D	RESETN	Active-Low Reset Output Connector	
E	OUT	Power Output Connector	Fixed output voltage of: 3.3V for the AS1325-33 (Marking: ASKY) 5.0V for the AS1325-50 (Marking: ASK6)
F	GND	Ground	

Jumper Description

Label	Name	Description	Info
G	OFF/ON	SHDNN Shutdown Jumper	 1/ON = The AS1325 is on.  0/OFF = The AS1325 is off and the current into BATT is $\leq 1\mu\text{A}$ (typ).

Measurement Points Description

Label	Name	Description	Info
H	SHDNN	Active-Low Logic Shutdown Input	Measurement Points
I	BATT	Power Supply Connectors for VBATT and Ground.	
J	GND		
K	RESETN	Active-Low Reset Output Connector	
L	OUT	Power Output Connector	
M	LX	External Conductor	

Operational sequence

The evaluation board is available with both output voltage versions of the AS1325. Please check which output voltage version of the AS1325 is soldered on the board. 3.3V for the AS1325-33 (Marking: ASKY) 5.0V for the AS1325-50 (Marking: ASK6)

1. If not present get the [datasheet](#) for the AS1325 from www.austriamicrosystems.com. Drive the IC on the Demoboard only with the recommended settings and values as described in the datasheet.
2. Connect a +1.5V to VOUT power supply (BATT “A” and GND “B”).
3. Perform measurements at the measurement points OUT “L” and GND “J”.

If there are questions do not hesitate to contact us. See contact information at the end of the application note.

Copyright

Copyright © 1997-2007, austriamicrosystems AG, Schloss Premstaetten, 8141 Unterpremstaetten, Austria-Europe. Trademarks Registered ®. All rights reserved. The material herein may not be reproduced, adapted, merged, translated, stored, or used without the prior written consent of the copyright owner.

All products and companies mentioned are trademarks or registered trademarks of their respective companies.

Copyright

Devices sold by austriamicrosystems AG are covered by the warranty and patent indemnification provisions appearing in its Term of Sale. austriamicrosystems AG makes no warranty, express, statutory, implied, or by description regarding the information set forth herein or regarding the freedom of the described devices from patent infringement. Austriamicrosystems AG reserves the right to change specifications and prices at any time and without notice. Therefore, prior to designing this product into a system, it is necessary to check with austriamicrosystems AG for current information.

This product is intended for use in normal commercial applications. Applications requiring extended temperature range, unusual environmental requirements, or high reliability applications, such as military, medical life-support or lifesustaining equipment are specifically not recommended without additional processing by austriamicrosystems AG for each application. For shipments of less than 100 parts the manufacturing flow might show deviations from the standard production flow, such as test flow or test location.

The information furnished here by austriamicrosystems AG is believed to be correct and accurate. However, austriamicrosystems AG shall not be liable to recipient or any third party for any damages, including but not limited to personal injury, property damage, loss of profits, loss of use, interruption of business or indirect, special, incidental or consequential damages, of any kind, in connection with or arising out of the furnishing, performance or use of the technical data herein. No obligation or liability to recipient or any third party shall arise or flow out of austriamicrosystems AG rendering of technical or other services.



Contact Information

Headquarters

austriamicrosystems AG
A-8141 Schloss Premstätten, Austria
T. +43 (0) 3136 500 0
F. +43 (0) 3136 5692

For Sales Offices, Distributors and Representatives, please visit:
<http://www.austriamicrosystems.com/contact>