

This document is the property of Amphenol Corporation and is delivered on the express condition that it is not to be disclosed, reproduced or used, in whole or in part, for manufacture or sale by anyone other than Amphenol Corporation without its prior consent, and that no right is granted to disclose or to use any information in this document.

The marking on this product doesn't contain environmental hazardous materials per Material Specification SS-00259 for Sony GP compliant or per directive 2011/65/EU for RoHS compliant.



ORIGINAL



REVISIONS				
SYM	ECN No.	DESCRIPTION	DATE	APPROVED
A		RELEASE TO PRODUCTION	09/30/2011	Roger Tsai
B	NE-12093	MODIFY DIMENSION "J" IN PAGE 2	06/13/2012	Roger Tsai
C	NE-15061	ADDED DIM & TOLERANCE	05/27/2015	Roger Tsai

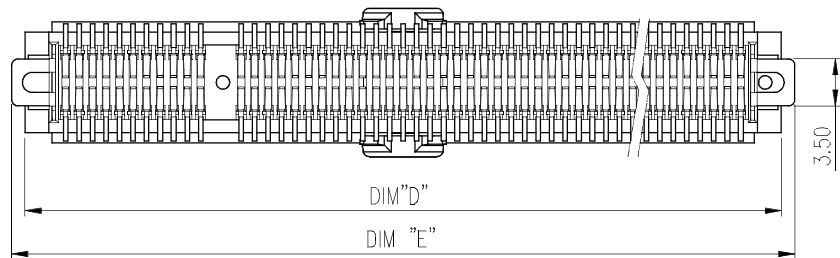
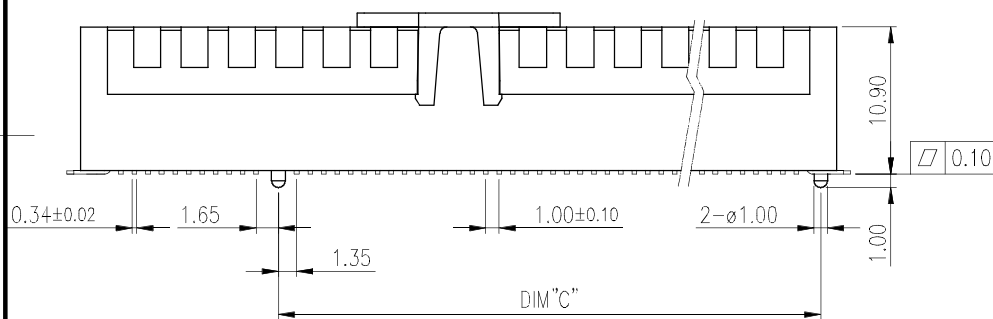
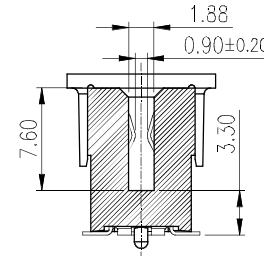
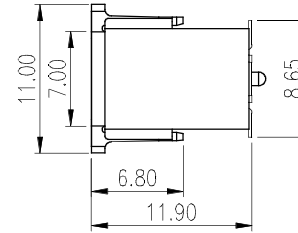
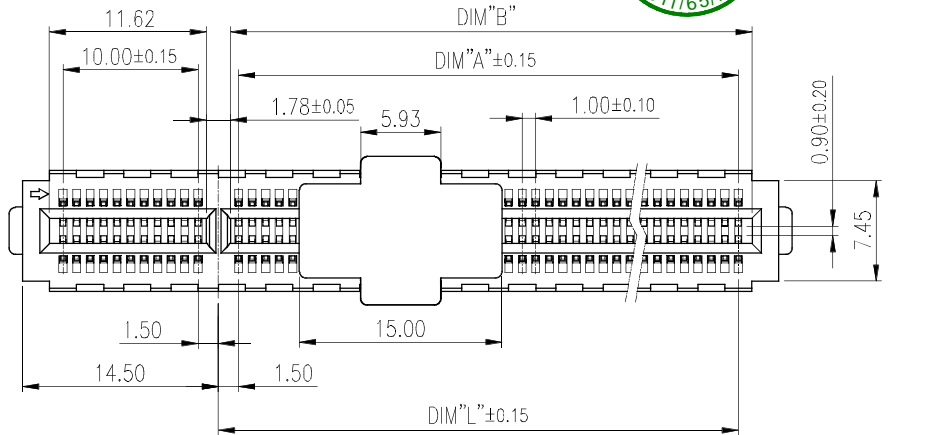

NOTES:

- MATERIAL:
 - HOUSING: HIGH TEMPERATURE THERMAL PLASTIC, UL94V-0. COLOR: OPTION.
 - CAP: HIGH TEMPERATURE THERMAL PLASTIC, UL94V-0. COLOR: BLACK.
 - TERMINAL: COPPER ALLOY.
 - FORKLOCK: COPPER ALLOY.
- FINISH:
 - TERMINAL:
 - CONTACT AREA: SELECTED GOLD PLATING;
 - SOLDERING AREA: TIN PLATING 100 μ" THICKNESS MIN.;
 - UNDER PLATING: NICKEL PLATING 50 μ" THICKNESS MIN. OVERALL
 - SOLDER PAD:
 - SOLDERING AREA: TIN PLATING 100 μ" THICKNESS MIN.;
 - UNDER PLATING: NICKEL PLATING 50 μ" THICKNESS MIN. OVERALL
- PACKING IS PER AMTA PACKING SPECIFICATION PKS-0001.
- THIS PRODUCT IS LEAD-FREE & RoHS COMPLIANT PRODUCT.

PART NO. G630HXXX6X1EU

NO. OF POSITION	COLOR
36: 36 POSITIONS	2: PA 9T, BLACK
64: 64 POSITIONS	6: PA 9T, WHITE
98: 98 POSITIONS	
AA: 164 POSITIONS	
	CONTACT FINISH
	0: GOLD FLASH
	1: 15 μ" GOLD
	2: 30 μ" GOLD
	3: 10 μ" GOLD

POSITION	DIM "A"	DIM "B"	DIM "C"	DIM "D"	DIM "E"	DIM "L"
36	6.00	7.65	9.15	25.00	27.00	7.50
64	20.00	21.65	23.15	39.00	41.00	21.50
98	37.00	38.65	40.15	56.00	58.00	38.50
164	70.00	71.65	73.15	89.00	91.00	71.50

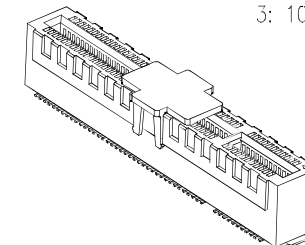

TOLERANCE	APPROVALS	DATE	TITLE		PART No.			
X. X.X ±0.30 X.XX ±0.20 X.XXX ±0.10	DRAWN Aqua Chou	05/27/2015	PCI EXPRESS EDGE CARD CONNECTOR SMT TYPE (3.0)		G630HXXX6X1EU			
	CHECKED Roger Tsai	05/27/2015			G630HXXX6X1EU			
ANGULAR ±1°	APPROVED Roger Tsai	05/27/2015			UNIT mm	SIZE A3	G630HXXX6X1EU	
UNLESS OTHERWISE SPECIFIED	DWG TYPE CUST DWG	PROJECT CODE SLOT			SCALE NA	SHEET 1 OF 3	DWG No. G630HXXX6X1EU	REV. C

This document is the property of Amphenol Corporation and is delivered on the express condition that it is not to be disclosed, reproduced or used, in whole or in part, for manufacture or sale by anyone other than Amphenol Corporation without its prior consent, and that no right is granted to disclose or to use any information in this document.

The marking on this product doesn't contain environmental hazardous materials per Material Specification SS-00259 for Sony GP compliant or per directive 2002/95/EC for RoHS compliant.



ORIGINAL



REVISIONS				
SYM	ECN No.	DESCRIPTION	DATE	APPROVED
A		RELEASE TO PRODUCTION	09/30/2011	Roger Tsai
B	NE-12093	MODIFY DIMENSION "J" IN PAGE 2	06/13/2012	Roger Tsai
C	NE-15061	ADDED DIM & TOLERANCE	05/27/2015	Roger Tsai

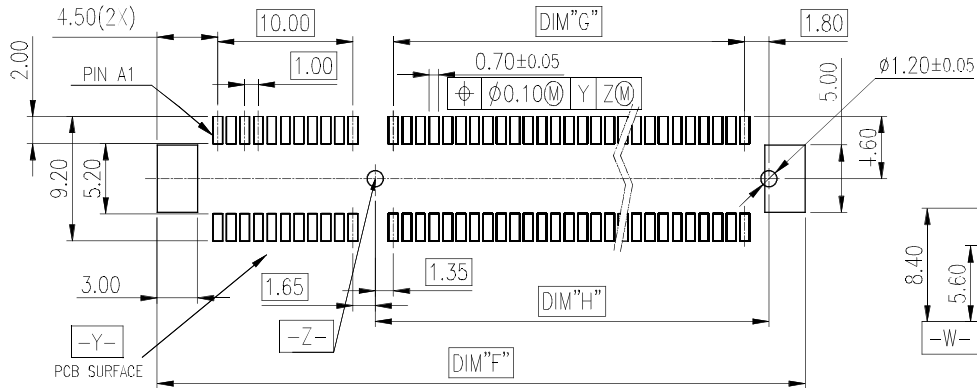

RECOMMENDED PCB LAYOUT, PAD TYPE

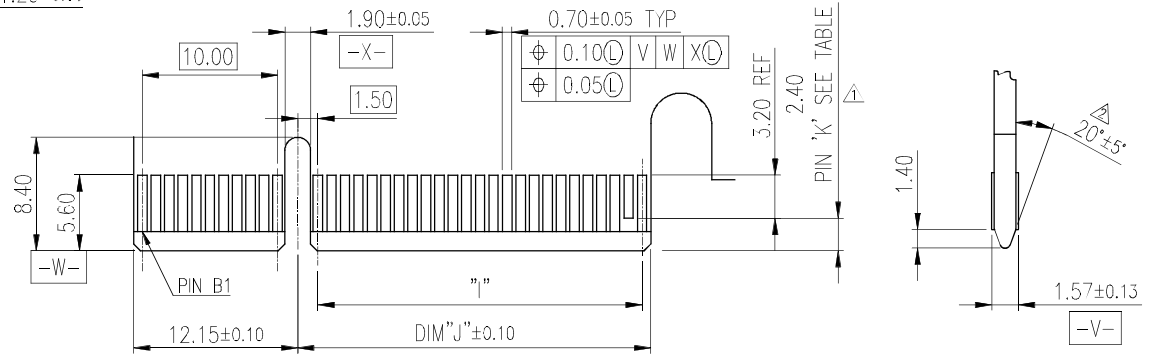

I/O PANEL DIRECTION
PRIMARY (COMPONENT) SIDE

POSITION	DIM "F"	DIM "G"	DIM "H"	DIM "I"	DIM "J"	"K"
36	28.00	6.00	9.15	6.00	8.15	B17
64	42.00	20.00	23.15	20.00	22.15	B31
98	59.00	37.00	40.15	37.00	39.15	B48
164	92.00	70.00	73.15	70.00	72.15	B81

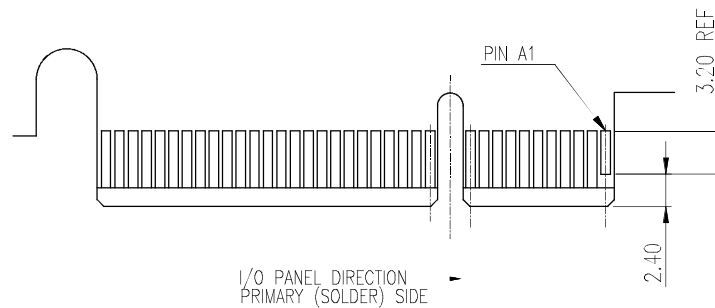

I/O PANEL DIRECTION
PRIMARY (SOLDER) SIDE

NOTES:

- △ NO TIE BAR PERMITTED FROM CARD EDGE TO LEADING EDGE OF PAD FOR PINS A1 AND "K".
- △ CHAMFER EDGES MUST BE FREE OF CUTTING BURRS.
- 3 TOLERANCE: .xx ±0.13.

TOLERANCE	APPROVALS	DATE	TITLE			Amphenol®		
X. X.X X.XX X.XXX	DRAWN Aqua Chou	05/27/2015	PCI EXPRESS EDGE CARD CONNECTOR SMT TYPE (3.0)			Amphenol Corporation Amphenol Taiwan Corporation		
	CHECKED Roger Tsai	05/27/2015						
ANGULAR ±1°	APPROVED Roger Tsai	05/27/2015	UNIT mm	SIZE A3	PART No.	G630HXXX6X1EU		
UNLESS OTHERWISE SPECIFIED	DWG TYPE CUST DWG	PROJECT CODE SLOT	SCALE NA	SHEET 2 OF 3	DWG No.	G630HXXX6X1EU		REV. C

This document is the property of Amphenol Corporation and is delivered on the express condition that it is not to be disclosed, reproduced or used, in whole or in part, for manufacture or sale by anyone other than Amphenol Corporation without its prior consent, and that no right is granted to disclose or to use any information in this document.

The marking on this product doesn't contain environmental hazardous materials per Material Specification SS-00259 for Sony GP compliant or per directive 2002/95/EC for RoHS compliant.



ORIGINAL



REVISIONS				
SYM	ECN No.	DESCRIPTION	DATE	APPROVED
A		RELEASE TO PRODUCTION	09/30/2011	Roger Tsai
B	NE-12093	MODIFY DIMENSION "J" IN PAGE 2	06/13/2012	Roger Tsai
C	NE-15061	ADDED DIM & TOLERANCE	05/27/2015	Roger Tsai

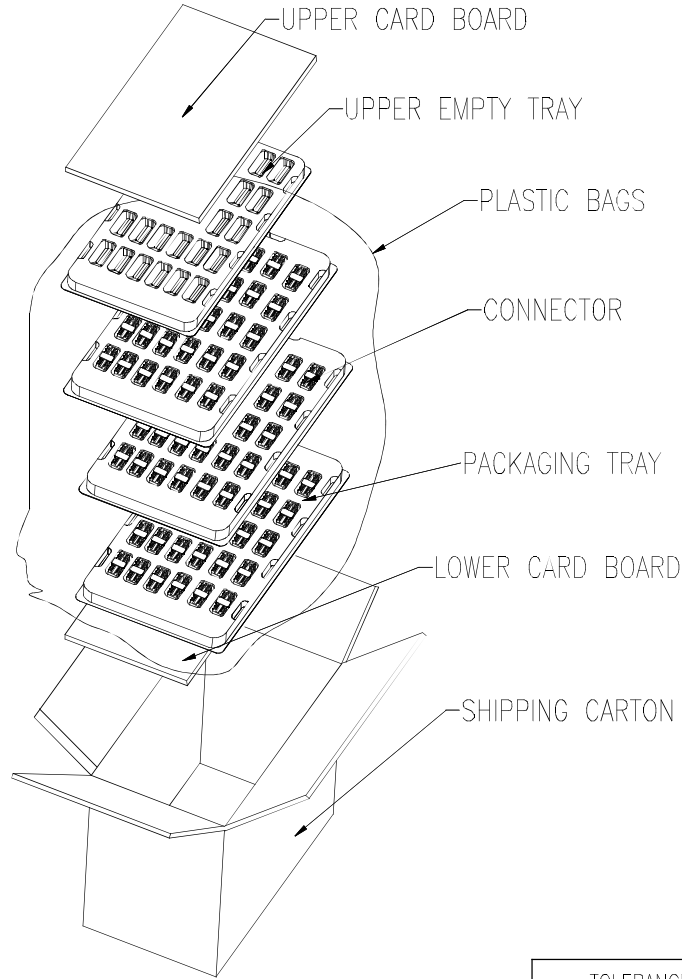

CIRCUIT SIZE	PARTS PER CARTON<S.P.Q>	PARTS PER TRAY	TOTEL TRAY PER CARTON
36	540	54	11
64	360	36	11
98	300	30	11
164	180	18	11

NOTES:

1. STAPLES SHOULD ONLY BE USED TO SET UP CARTON. ALL CARTON CLOSURE MUST BE DONE WITH TAPE.
 2. FILL PACKAGING TRAYS WITH THE QUANTITIES AS INDICATED IN THE CHART.
3. IN THE 11 PLASTIC TRAYS ,THE TOP PLASTIC TRAY IS TO COVER THE CONNECTORS ,THE OTHERS ARE FILLED WITH CONNECTORS.

TOLERANCE	APPROVALS	DATE	TITLE			Amphenol®		
X. X.X ±0.30 X.XX ±0.20 X.XXX ±0.10	DRAWN Aqua Chou	05/27/2015	PCI EXPRESS EDGE CARD CONNECTOR SMT TYPE (3.0)			Amphenol Corporation Amphenol Taiwan Corporation		
	CHECKED Roger Tsai	05/27/2015						
ANGULAR ±1°	APPROVED Roger Tsai	05/27/2015		UNIT mm	SIZE A3	PART No. G630HXXX6X1EU		
UNLESS OTHERWISE SPECIFIED	DWG TYPE CUST DWG	PROJECT CODE SLOT		SCALE NA	SHEET 3 OF 3	DWG No. G630HXXX6X1EU	REV. C	