

REVISIONS			
REV	DESCRIPTION, ECN, EAR NO.	DATE	APP'D
A	PROPOSAL DWG (EAR 13867)	MAY06/11	
B	UPDATED POWER CONTACTS	MAY11/12	S.M

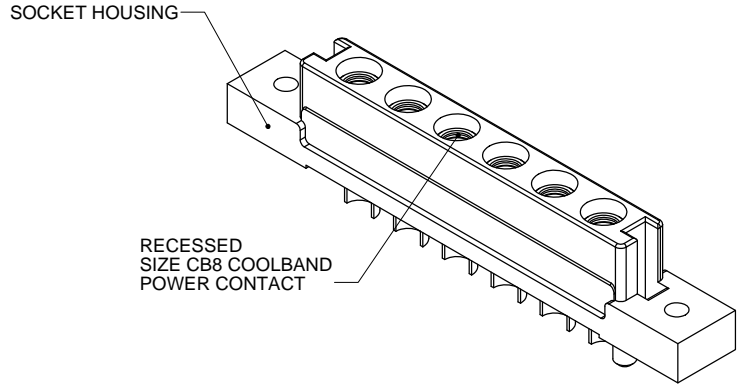
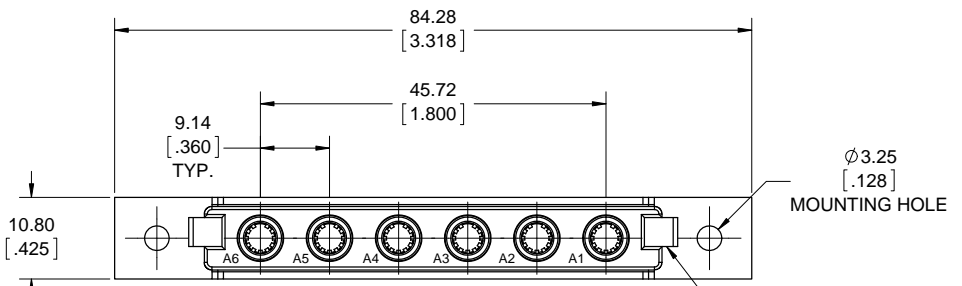

SLOT ACCEPTS PIN CONNECTOR HOUSING BLADE LOCATED OFF CENTRE TO PREVENT IMPROPER MATING

RECESSED SIZE CB8 COOLBAND POWER CONTACT

AMPHENOL PART NUMBER: DWR-T600S-V212-90

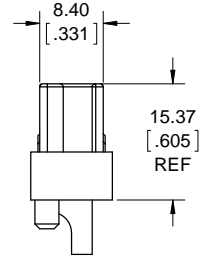
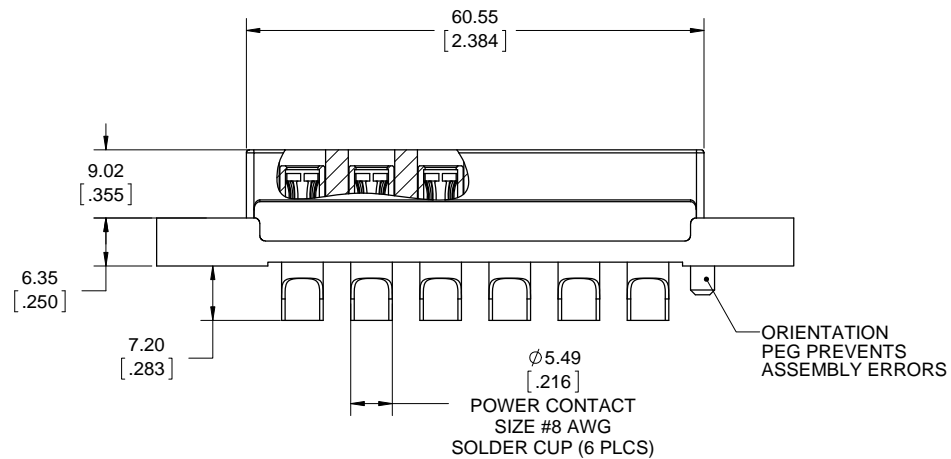

NOTES:

- MATERIALS: ALL MATERIALS ARE RoHS COMPLIANT PER EU DIRECTIVE 2002/95/EC AND AMENDMENTS.
 - HOUSING: HIGH TEMPERATURE RESISTANT NYLON, UL FLAMMABILITY RATING 94V-0, COLOUR BLACK
 - POWER CONTACTS: BERYLLIUM COPPER MATING GRID, TELLURIUM COPPER ALLOY BALANCE. MATING AREA PLATED WITH 0.38µm (15µ") GOLD OVER 1.27µm (50µ") NICKEL, SILVER BALANCE
- WHEN MATED WITH PIN CONNECTOR P/N DWR-T600P-V212-90, THE ORDER OF MECHANICAL AND ELECTRICAL ENGAGEMENT IS A) HOUSING BLADES, B) HOUSING SHROUD, C) TWO EXTENDED "FIRST MAKE" POWER CONTACTS IN POSITIONS A1 AND A6 AND D) FOUR STANDARD POWER CONTACTS IN POSITIONS A2, A3, A4 AND A5.
- RATINGS SUBJECT TO DESIGN QUALIFICATION TESTING
 - CURRENT RATING: 55A
 - DIELECTRIC WITHSTANDING VOLTAGE: 1500VDC
 - INSULATION RESISTANCE: 5000 MEGAOHMS
 - OPERATING TEMPERATURE: -55C TO +105

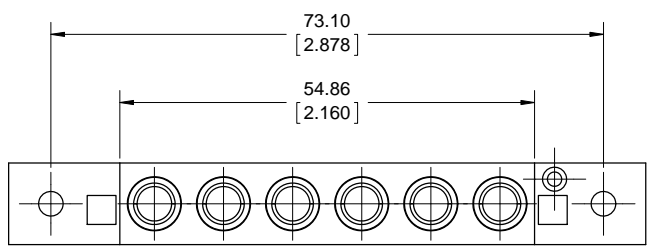

THIS DOCUMENT CONTAINS PROPRIETARY INFORMATION AND SUCH INFORMATION MAY NOT BE DISCLOSED TO OTHERS FOR ANY PURPOSE OR USED FOR MANUFACTURING PURPOSES WITHOUT WRITTEN PERMISSION FROM AMPHENOL CANADA CORP.

UNLESS SPECIFIED OTHERWISE	DRAWN	S.CAELERS	MAY06/11
PRIMARY UNITS MILLIMETERS	CHECKED		
SECONDARY INCHES	M.E. APP'D		
REFERENCE IN PARENTHESES	Q.A. APP'D		
GENERAL TOLERANCES	DWG APPR.		
1 DECIMAL PLACE	ENG. REL. NO.	EAR 13867	
2 DECIMAL PLACES	REF.		
3 DECIMAL PLACES	THIRD ANGLE PROJECTION		
ANGULAR DEGREES	DO NOT SCALE DRAWING		

Amphenol Canada Corp.			
DWR SERIES SLIM DRAWER 6 SOCKET CONNECTOR, SPECIAL RECESSED SIZE CB8 COOL POWER, SOLDER CUP TAILS (#8 AWG), RoHS COMPLIANT			
DWG. NO.	P-DWR-T600S-V212-90	REV	B
CODE ID NO.	03554	DWG SIZE:	X
SCALE:	2:1	SHEET	1 OF 2

REVISIONS			
REV	DESCRIPTION, ECN, EAR NO.	DATE	APPD
A	PROPOSAL DWG (EAR 13867)	MAY06/11	
B	UPDATED POWER CONTACTS	MAY11/12	S.M

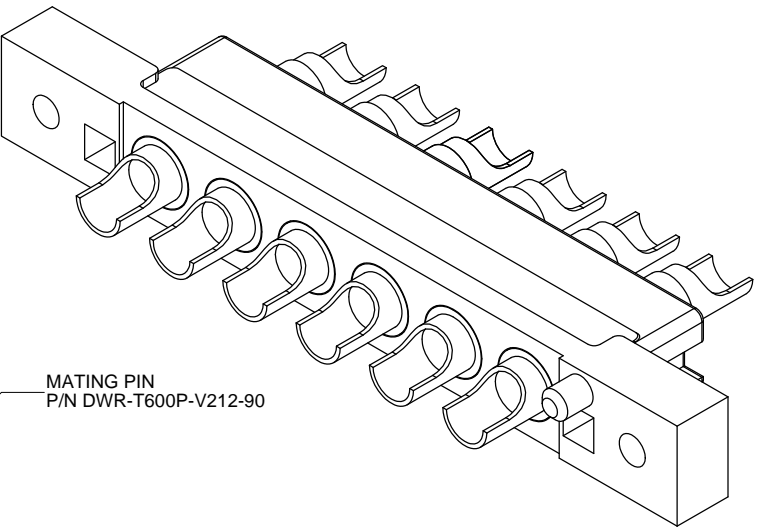

MATING PIN
P/N DWR-T600P-V212-90

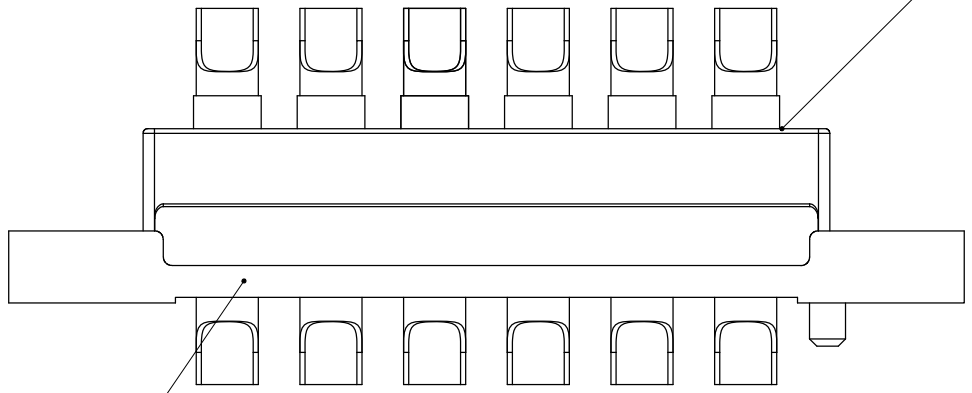

SOCKET CONNECTOR
P/N DWR-T600S-V212-90

MATED ASSEMBLY
SIDE VIEW
SCALE 3:1



UNLESS SPECIFIED OTHERWISE	DRAWN	S.CAELERS	MAY06/11
PRIMARY UNITS MILLIMETERS	CHECKED		
SECONDARY INCHES	M.E. APPD		
REFERENCE IN PARENTHESES	Q.A. APPD		
GENERAL TOLERANCES	DWG APPR.		
1 DECIMAL PLACE	ENG. REL. NO.	EAR 13867	
2 DECIMAL PLACES	REF.		
3 DECIMAL PLACES	THIRD ANGLE PROJECTION		DO NOT SCALE DRAWING
ANGULAR DEGREES			

Amphenol Canada Corp.			
DWR SERIES SLIM DRAWER 6 SOCKET CONNECTOR, SPECIAL RECESSED SIZE CB8 COOL POWER, SOLDER CUP TAILS (#8 AWG), RoHS COMPLIANT			
DWG. NO.	P-DWR-T600S-V212-90		REV B
CODE ID NO.	03554	DWG SIZE: X	SCALE: 2:1 SHEET 2 OF 2

THIS DOCUMENT CONTAINS PROPRIETARY INFORMATION AND SUCH INFORMATION MAY NOT BE DISCLOSED TO OTHERS FOR ANY PURPOSE OR USED FOR MANUFACTURING PURPOSES WITHOUT WRITTEN PERMISSION FROM AMPHENOL CANADA CORP.