

General Description

The AOZ1960 is a high-efficiency boost regulator with integrated 55V boost switch and 30V input protection switch. It is designed to drive 6 parallel strings of multiple series-connected white LEDs for LCD backlight applications. The current of each string is individually regulated by an internal current regulator. The AOZ1960 has a wide input voltage range from 7V to 24V. The maximum LED current can be adjusted from 15mA to 30mA using an external resistor connected to ISET pin.

The AOZ1960 support two dimming control modes to enable a wide variety of applications. In analog dimming mode, the LED current can be directly adjusted through ABRT pin to achieve 10% to 100% brightness range. In digital dimming mode, a PWM signal on DBRT controls the brightness by turning the current regulators on and off. The brightness is proportional to the duty cycle of the PWM signal.

The AOZ1960 has multiple features to protect the regulator under fault conditions. An internal 30V input protection switch protects against catastrophic failure conditions such as output short-circuits. A separate over-voltage protection (OVP) loop limits the output voltage if LED strings fail open. Cycle-by-cycle over-current protection (OCP) limits the peak inductor current. Built-in soft-start minimizes the inrush current during startup. Thermal shutdown provides another level of protection.

The integrated 55V power MOSFET reduces the cost and external component count, while allowing output voltages as high as 55V. Low dropout voltage of LED current regulator (500mV) minimizes power loss. In addition, automatic pulse skipping operation improves efficiency at light loads. The AOZ1960 features programmable switching frequency allows for trade-offs between solution size and electrical efficiency.

The AOZ1960 is available in a thermally enhanced 24-pin 7mm x 4mm DFN package and operates over the temperature range of -40°C to +85°C.

Features

- 7V to 24V input voltage range
- Integrated 30V input switch
- 55V/2A internal N-channel MOSFET
- Six parallel strings
- Programmable switching frequency
- 500mV low dropout current regulator
- Resistor programmable maximum LED current
- Analog dimming via ABRT pin
- Digital PWM dimming via DBRT pin
- Dimming range with 8-bit resolution
- Cycle-by-cycle current limit
- Open and short LED protection
- Output over-voltage and short protection
- Thermal overload protection
- Internal Soft-start
- 7mm x 4mm DFN package

Applications

- Notebook PC display
- Tablet PC display
- Desktop monitors
- Portable DVD players
- Digital photo frames
- Car navigation display



Typical Application Circuit

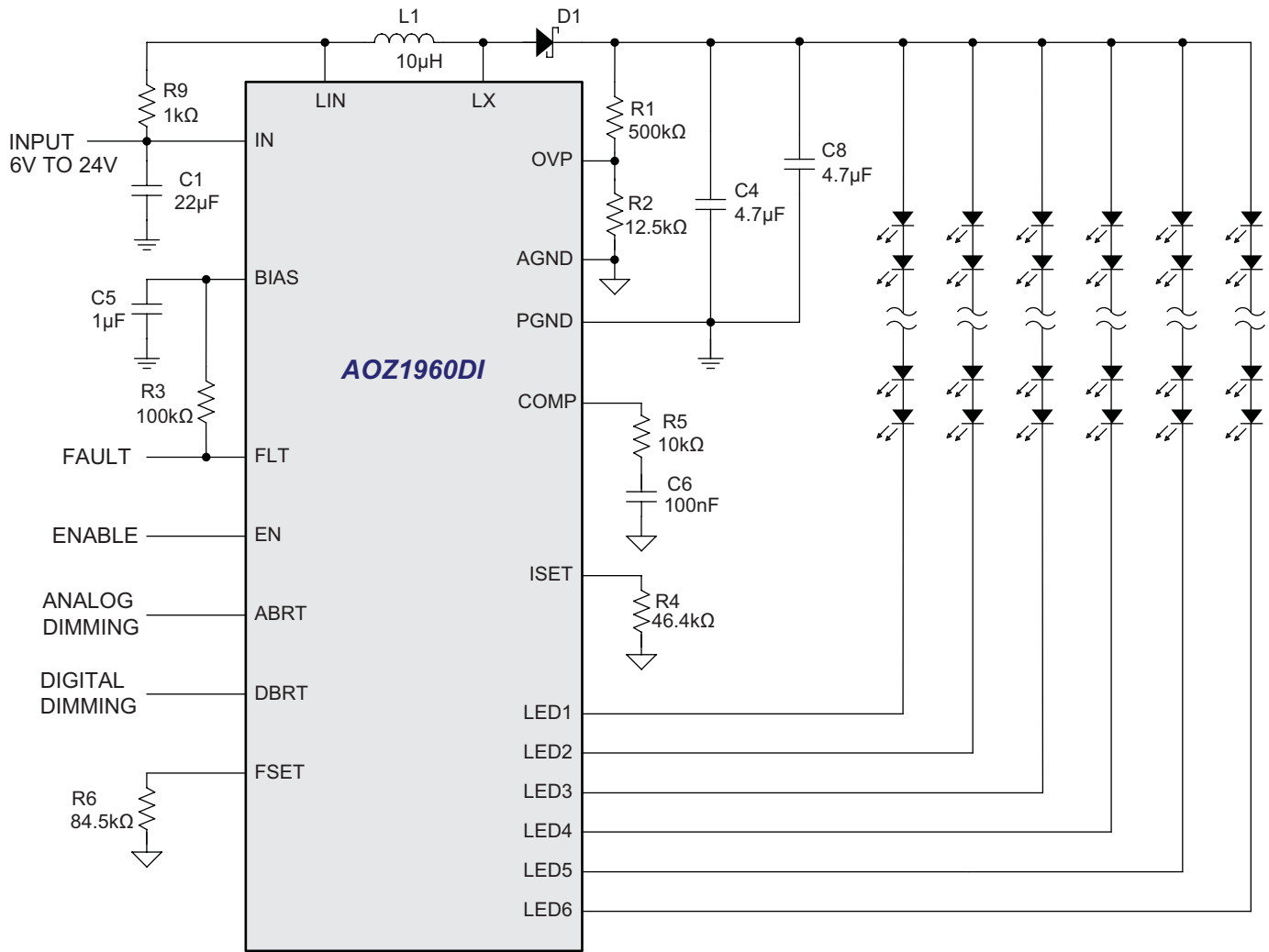

Ordering Information

Part Number	Ambient Temperature Range	Package	Environmental
AOZ1960DI	-40°C to +85°C	7 x 4 DFN-24	Green Product



AOS Green Products use reduced levels of Halogens, and are also RoHS compliant.

Please visit www.aosmd.com/web/quality/rohs_compliant.jsp for additional information.

Pin Configuration

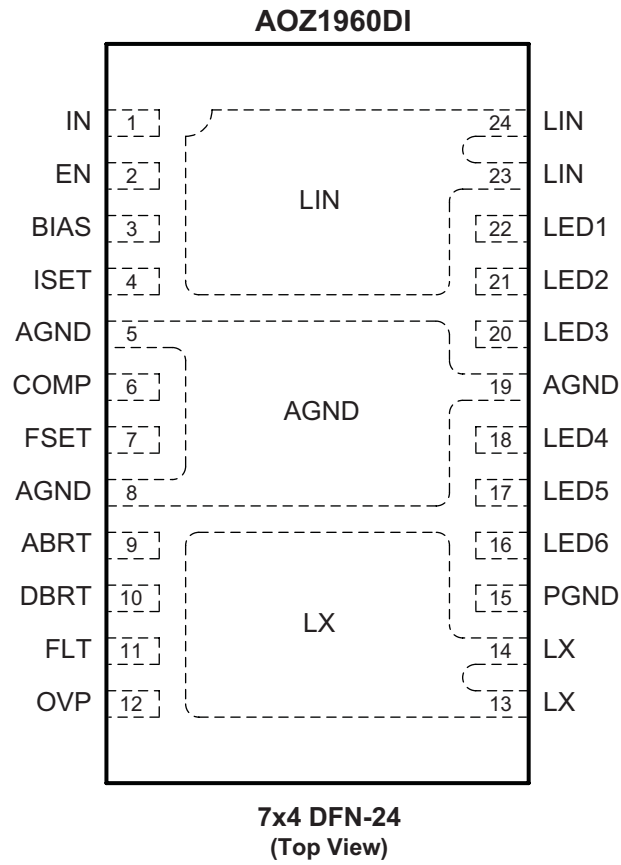

Pin Description

Pin Number	Pin Name	Pin Function
1	IN	Input Supply Pin.
2	EN	Enable Input. Pull EN above 2V to enable the LED driver and pull EN below 0.8V to disable the LED driver.
3	BIAS	Internal 5V Linear Regulator Output. Connect a minimum 0.22 μ F ceramic capacitor from BIAS to ground.
4	ISET	LED Current Set Pin. Connect a resistor from ISET to ground to set the nominal LED current (100% brightness) for each string.
5, 8, 19	AGND	Analog ground.
6	COMP	Compensation Pin. COMP is the output of the internal error amplifier. Connect a RC network from COMP to ground to compensate the control loop.
7	FSEL	Frequency Select Pin. Connect FSEL to ground via a resistor to set the switching frequency.
9	ABRT	Analog Brightness Control Input. ABRT controls the LED brightness by adjusting the LED current in proportion to ABRT voltage. The input range of ABRT is between 0 to 2V. When VBRT is below 0.2V, the LED current is 10% of the nominal setting. When BRT voltage is 2V or above, the LED current is 100% of the normal setting.
10	DBRT	PWM Brightness Control Input. DBRT controls the LED brightness by turning the LED on and off using a PWM signal. The brightness is proportional to the PWM duty.
11	FLT	Fault Output. FLT is an open-drain output. Connect a pull-up resistor between BIAS and FLT.
12	OVP	Over-voltage protection Input. Use a voltage divider to set the boost regulator output over-voltage protection threshold.
13, 14	LX	Boost Regulator Switching Pin. LX is the drain of the 55V internal boost switch.
15	PGND	Power Ground.
16	LED6	Internal LED Current Regulator 1 Input.
17	LED5	Internal LED Current Regulator 2 Input.
18	LED4	Internal LED Current Regulator 3 Input.
20	LED3	Internal LED Current Regulator 4 Input.
21	LED2	Internal LED Current Regulator 5 Input.
22	LED1	Internal LED Current Regulator 6 Input.
23, 24	LIN	Boost Regulator Input Pin. LIN is drain of the input protection switch.

Block Diagram

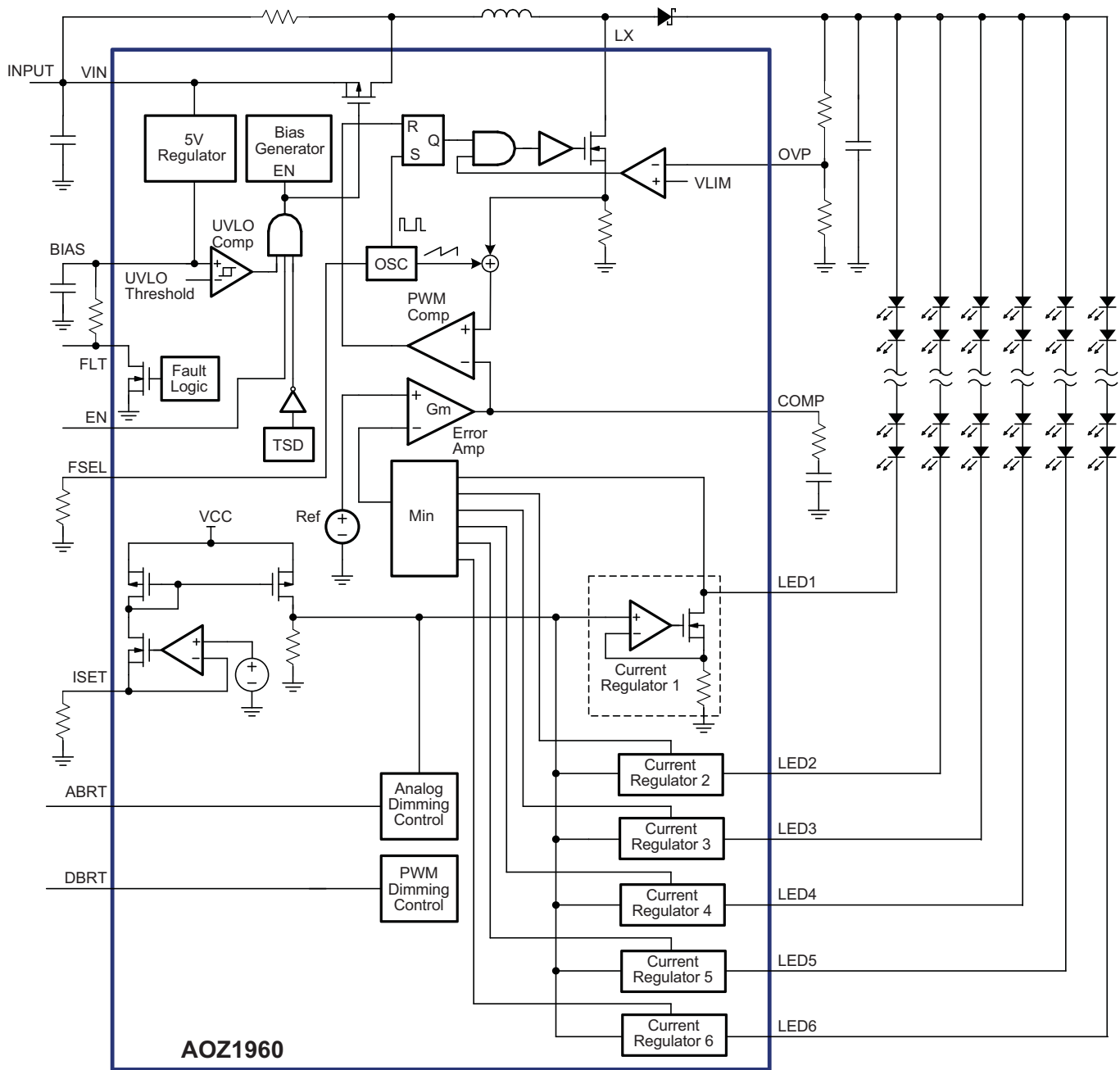

Absolute Maximum Rating

Exceeding the Absolute Maximum Ratings may damage the device.

Parameter	Rating
IN, LIN to AGND	-0.3V to +28V
LX to AGND	-0.3V to +60V
LED1, LED2, LED3, LED4, LED5, LED6 to AGND	-0.3V to +40V
BIAS, EN, FLT, FSEL, ISET, COMP, ABRT, DBRT, OVP, to AGND	-0.3V to +6V
Storage Temperature (T _S)	-65°C to +150°C
ESD Rating ⁽¹⁾	2kV

Note:

1. Devices are inherently ESD sensitive, handling precautions are required. Human body model rating: 1.5kΩ in series with 100pF.

Maximum Operating Ratings

The device is not guaranteed to operate beyond the Maximum Operating Ratings.

Parameter	Rating
Supply Voltage (V _{IN})	7V to 24V
Ambient Temperature (T _A)	-40°C to +85°C
Package Thermal Resistance 7x4 DFN-24 (Θ _{JA})	45°C/W

Electrical Characteristics

T_A = 25°C, V_{IN} = 3.3V, unless otherwise specified.

Symbol	Parameter	Conditions	Min.	Typ.	Max.	Units
V _{IN}	IN Supply Voltage	10 LEDs per channel (3.2V/20mA type)	7		24	V
I _{IN_ON}	IN Quiescent Current	EN = 5V			2.5	mA
I _{IN_OFF}	IN Shutdown Current	EN = AGND		10	40	μA
V _{BIAS}	BIAS Regulation Voltage		4.7	5.0	5.3	V
V _{BIAS_UVLO}	BIAS UVLO Threshold	V _{EN} = 5V		4.3	4.5	V
V _{BIAS_HYS}	BIAS UVLO Hysteresis	V _{EN} = 5V		700		mV
INPUT SWITCH						
	IN to LIN On Resistance			50	80	mΩ
	IN to LIN Leakage				1	μA
LED CURRENT REGULATION						
I _{LED_MAX}	LED_ Full Scale Current	R _{ISET} = 46.4kΩ		20.0		mA
V _{LED_}	Minimum LED_ Regulation Voltage	I _{LED_} = 20mA		500		mV
	LED_ Leakage Current	V _{LED_} = 36V			200	μA
	Current Matching Accuracy	I _{LED_} = 20mA	-3		+3	%
BRIGHTNESS CONTROL						
	DBRT Input High Voltage		2			V
	DBRT Input Low Voltage				0.6	V
	DBRT Input Bias Current				200	nA
	DBRT Input Frequency ⁽²⁾		2		20	kHz
	ABRT Input Range		0		5.5	V
	ABRT Full Scale Voltage		1.9			V
	ABRT 10% Scale Voltage				0.25	V
	ABRT Leakage Current				200	nA

Electrical Characteristics (Continued)

 $T_A = 25^\circ\text{C}$, $V_{IN} = 3.3\text{V}$, unless otherwise specified.

Symbol	Parameter	Conditions	Min.	Typ.	Max.	Units
OSCILLATOR						
f_{SW}	Switching Frequency	RSEL = 84.5k Ω	800	1000	1200	kHz
D_{MAX}	Maximum Duty Cycle			87		%
POWER SWITCH						
R_{ON_LX}	LX On Resistance			0.14	0.20	Ω
	LX Leakage Current				1	μA
PROTECTIONS						
I_{LIM}	Current Limit			2.5		A
V_{OVP}	OVP Threshold Voltage		1.18	1.25	1.33	V
V_{OVP_HYS}	OVP Hysteresis			70		mV
I_{OVP}	OVP Input Bias Current				0.2	μA
	FLT On Resistance			300		Ω
	FLT Leakage Current				100	nA
T_{SD}	Thermal Shutdown Threshold			145		$^\circ\text{C}$
	Thermal Shutdown Hysteresis			35		$^\circ\text{C}$
LOGIC INPUT						
VEN_H	EN Logic High Threshold		2.0			V
VEN_L	EN Logic Low Threshold				0.6	V
VEN_HYS	EN Input Hysteresis			180		mV
IEN	EN Leakage Current	$V_{EN} = 5\text{V}$			1	μA
	FSEL Leakage Current				1	μA

Note:

2. DBRT Input Frequency is guaranteed by design only.

Typical Operating Characteristics

Electrical Efficiency

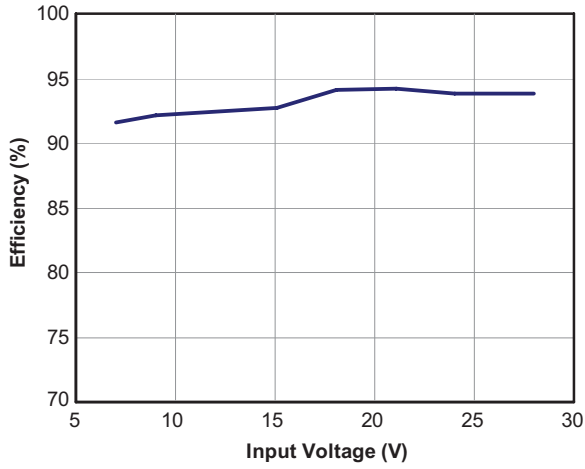

LED Current Regulation

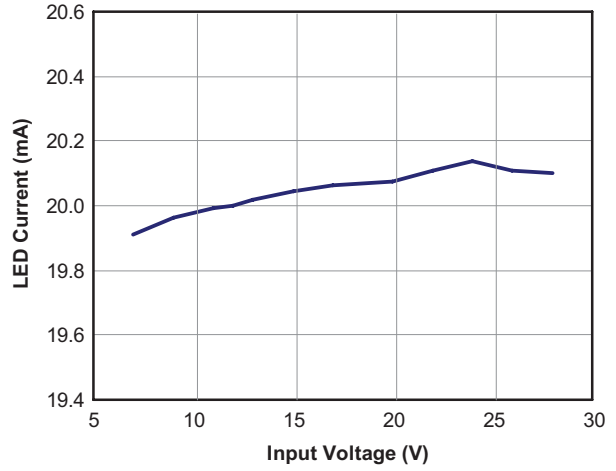

PWM Dimming Linearity

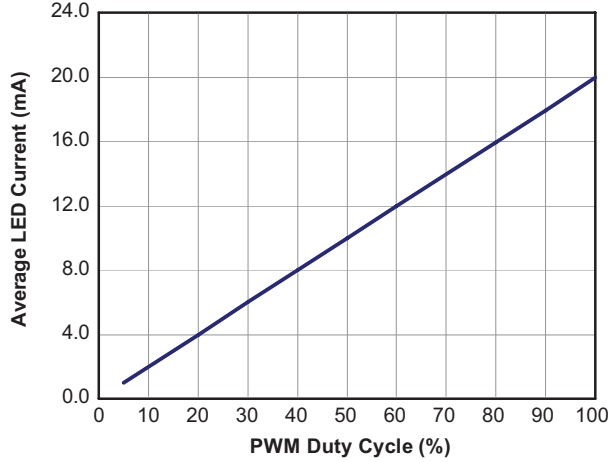

Analog Dimming Linearity

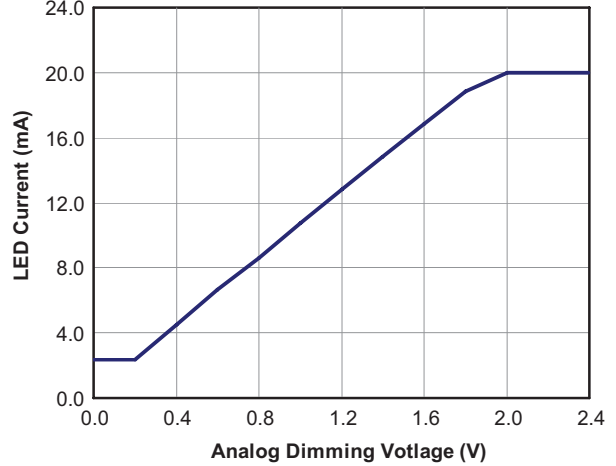

Typical Operating Characteristics (Continued)

Startup Waveforms (Vin = 12V)

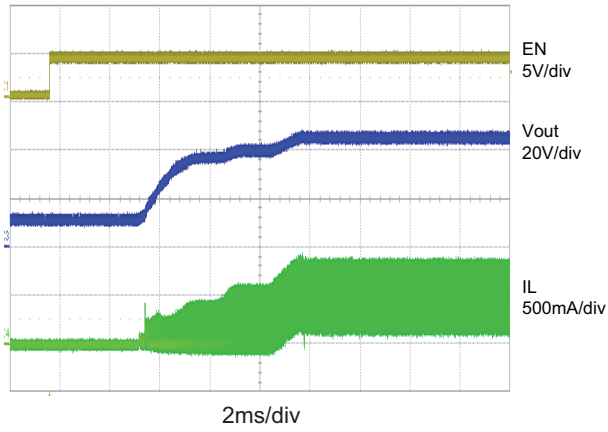

Switching Waveforms (Vin = 12V)

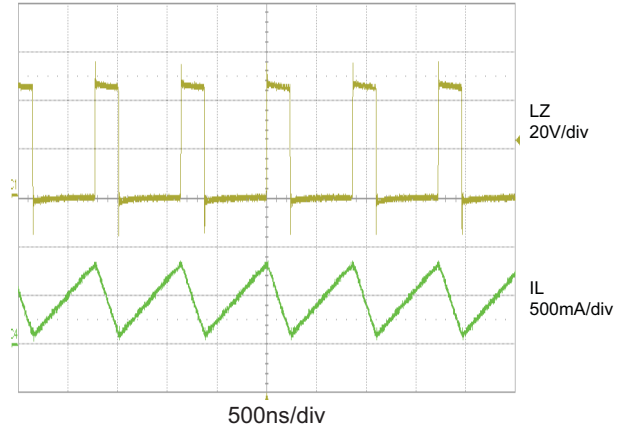

Switching Waveforms (Vin = 7V)

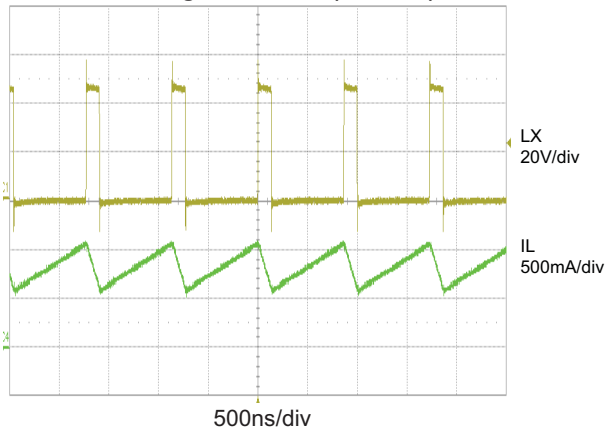

Switching Waveforms (Vin = 24V)

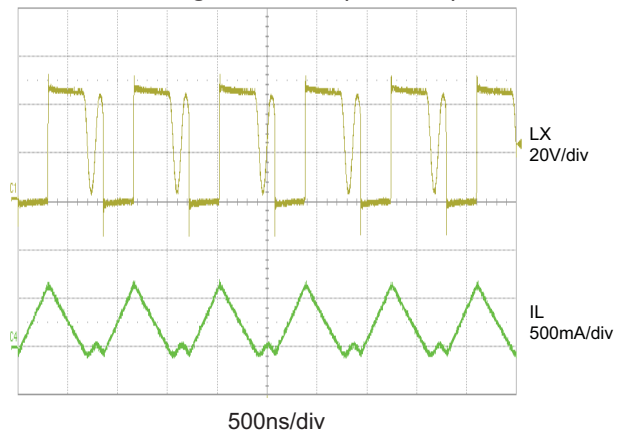

Typical Operating Characteristics (Continued)

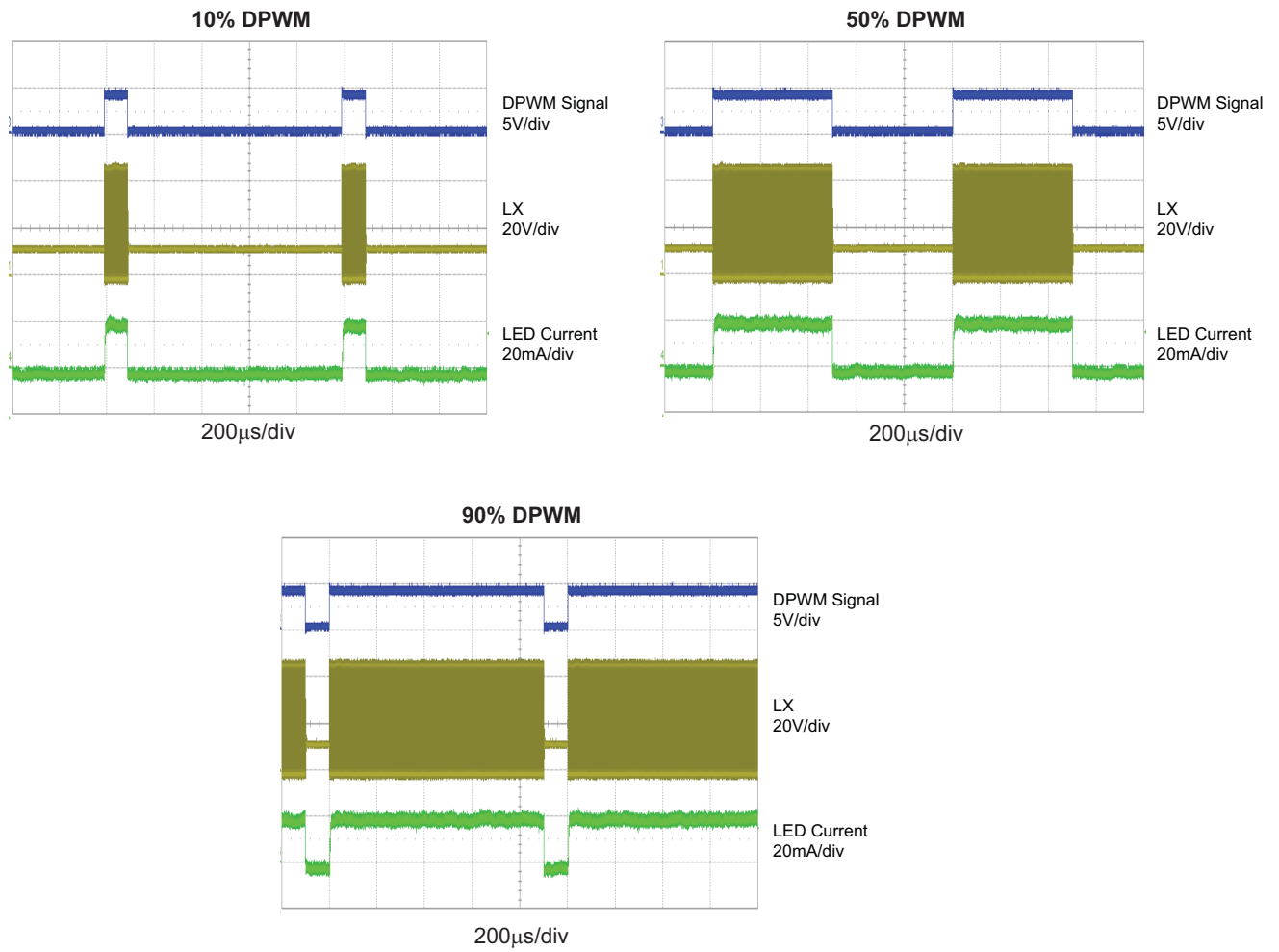

Typical Operating Characteristics (Continued)

Output Short to GND (Hard-short)

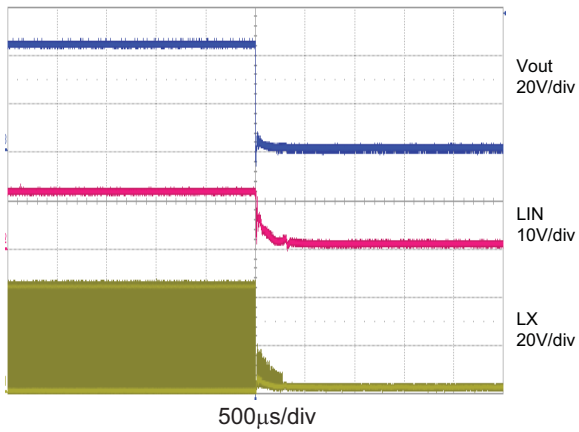

Output Short to GND (Soft-short)

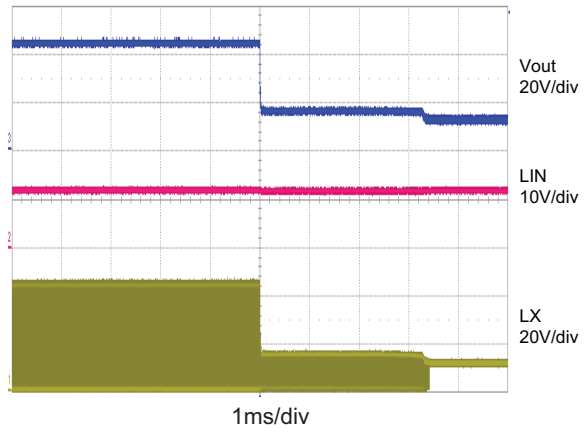

LED Short Protection

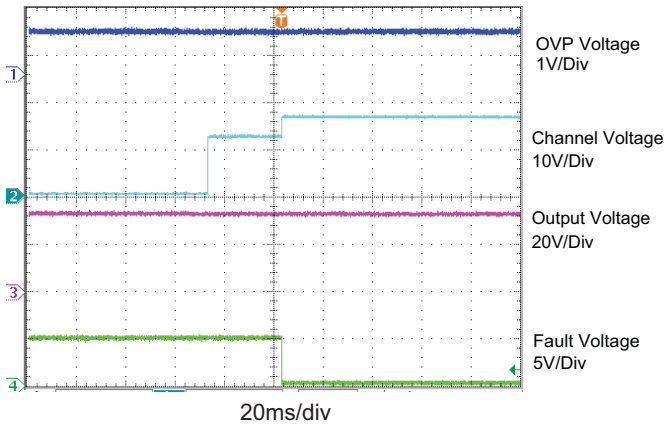

LED Open Protection

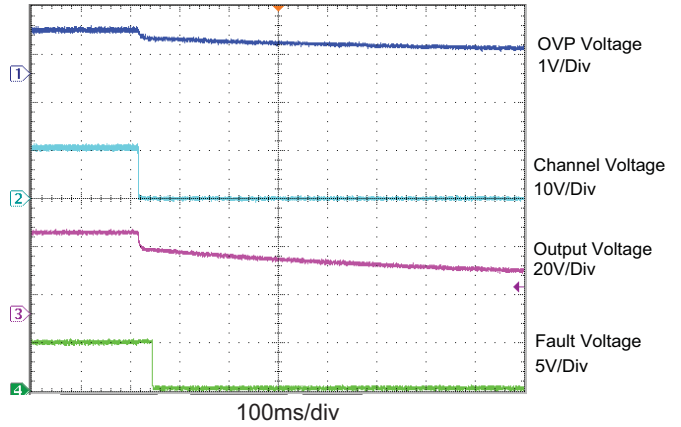

Detailed Description

AOZ1960 is a 6-string boost LED driver with integrated boost switch and input protection switch. The input voltage range is from 7V to 24V and output voltage can go as high as 55V and drive up to 12 LEDs in series for each string. LED current of each string is individually regulated by an internal current regulator to achieve $\pm 3\%$ current matching. AOZ1960 supports two brightness control methods: analog dimming and digital dimming. In analog dimming mode, the LED current can be directly adjusted through ABRT pin to achieve 10% to 100% brightness range. In digital dimming mode, a PWM signal on DBRT controls the brightness by turning the current regulators on and off. The brightness is proportional to the duty cycle of the PWM signal. The maximum LED current is set with an external resistor in ISET pin.

AOZ1960 features multiple protection functions. The cycle by cycle over-current protection (OCP) limits the inductor peak current to less than 2.5A. The input protection switch turns off when a short circuit is detected at the output. The cycle by cycle over-voltage protection (OVP) prevents the output voltage from running away when LED strings are open. OVP threshold can be adjusted using a voltage divider. The maximum allowed output voltage is 55V. Thermal shutdown function provides another layer of protection when junction temperature reaches 145°C. Internal soft-start effectively limits the inrush current during startup. In addition, AOZ1960 provides an open-drain fault indicator when a fault such as open LED, shorted LED, short circuit, or over temperature occurs.

Normal Operation

AOZ1960 boost LED driver uses constant frequency PWM control architecture. Different from regular boost regulators which regulate output voltage, AOZ1960 regulates LED current.

There are six internal current regulators. The minimum of the six current sense signals is fed to a transconductance error amplifier and compared with an internal reference. The PWM comparator compares the error amplifier output with the inductor current ramp signal to set a flip-flop, which turns off the boost switch. The boost switch turns on when the oscillator clock comes, connecting the inductor between the input supply and ground. The inductor current linearly ramps up storing energy in the magnetic field. The boost switch is turned off by PWM comparator. When the boost switch is off, the inductor current freewheels through the output Schottky diode, connecting the inductor between the input supply and output. The inductor current linearly ramps down and

energy stored in the inductor is transferred to the output. Therefore, if minimum of the six current sense signals is below internal reference, AOZ1960 will keep boosting the output voltage until it reaches regulation. This control method ensures the output voltage is just high enough to drive all six LED strings without wasting any extra power.

Input Protection Switch (LIN)

A major problem of traditional boost regulators is that they cannot protect against output short-circuit fault. When the output is shorted to ground, short-circuit current will flow directly from input supply, through the inductor and Schottky diode, to ground. Typically a fuse is required for output short-circuit protection. AOZ1960 solves this issue by integrating a high-voltage (30V) low on-resistance (50m Ω) P-channel input protection switch. The input switch is connected between the input supply (IN) and boost inductor (LIN). In normal operation, the switch is fully turned on connecting the input supply to the inductor. The input switch is turned off whenever AOZ1960 detects the output voltage is below the input. To ensure startup, a startup resistor (1k Ω) should be connected between IN (source of input switch) and LIN (drain of input switch) to make sure output is close to input before AOZ1960 is enabled.

Linear Regulator (BIAS)

AOZ1960 has an internal 5V linear regulator that powers all the internal circuitry including power MOSFET driver. BIAS is the output of the internal regulator. Connect a 1 μ F or larger ceramic capacitor between BIAS and ground. The regulator is used for internal circuitry only. Do not connect any external load to BIAS pin.

The regulator is enabled when EN is logic high. If BIAS voltage is above UVLO threshold (4.3V), AOZ1960 is enabled: the input switch is turned on and the boost regulator starts switching. If BIAS voltage is below UVLO threshold, AOZ1960 remains off.

Current Regulators (LED1 to LED6)

There are six internal current regulators. Each consists of a driver, a MOSFET, and a current sense resistor. The driver controls the MOSFET gate voltage based on the current sense feedback to achieve current regulation. When current sense signal is below a preset regulation point, the driver will reduce the MOSFET drain-to-source voltage by increasing gate voltage, allowing more voltage across the LED string. When current sense signal is above the regulation point, the driver will increase the MOSFET drain-to-source voltage by lowering gate

voltage, reducing voltage across the LED string. There are six internal current regulators. Each consists of a driver, a MOSFET, and a current sense resistor. The driver controls the MOSFET gate voltage based on the current sense feedback to achieve current regulation. When current sense signal is below a preset regulation point, the driver will reduce the MOSFET drain-to-source voltage by increasing gate voltage, allowing more voltage across the LED string. When current sense signal is above the regulation point, the driver will increase the MOSFET drain-to-source voltage by lowering gate voltage, reducing voltage across the LED string.

When one or two LEDs in a string are shorted, the current regulator in that string takes the additional voltage drop and continues to regulate LED current. If four or more LEDs in a string are shorted, the current regulator in that string is disabled and AOZ1960 ignores the current feedback signal from that string.

Analog Dimming

AOZ1960 supports analog dimming through ABRT pin. In analog dimming mode, LED current linearly changes with ABRT voltage. The current adjustment range is from 10% to 100% of the full brightness LED current, corresponding to 0.2V to 2V on ABRT. When ABRT is below 0.2V, LED current remains at 10%. When ABRT is above 2V, LED current remains at 100%. To disable analog dimming, connect ABRT to a voltage higher than 4V.

DPWM Dimming

AOZ1960 supports digital PWM dimming through DBRT pin. In DPWM dimming mode, current regulators are turned on and off by a PWM signal on DBRT. The brightness is proportional to the duty cycle of the PWM signal. For example, the duty cycle can be adjusted from 3% to 100% for 20kHz DPWM frequency.

Applications Information

LED Current Setting

The maximum LED current is set with an external resistor in ISET pin. The current can be set from 15mA to 25mA.

RSET can be calculated using Eq. 1:

$$I_{LED} = \frac{928}{R_{SET}} \quad (\text{Eq. 1})$$

R _{SET} (Ω)	I _{LED} (mA)
62k	15
46.4k	20
37k	25

To set the LED current from 15mA to 25mA, use the figure below.

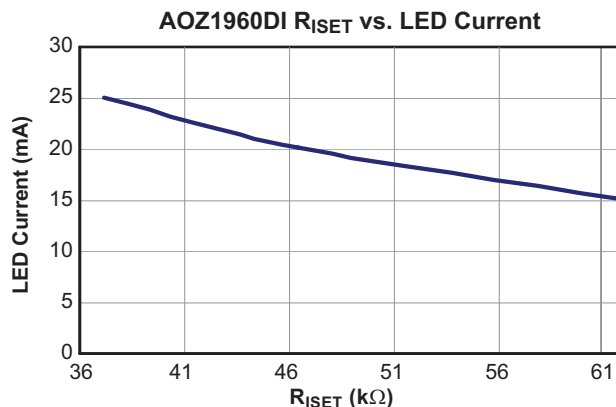

Input Capacitor

The input capacitor is connected to VIN and GND pins of the AOZ1960 to filter and maintain a steady input DC voltage. The voltage rating of input capacitor must be greater than maximum input voltage plus ripple voltage. The RMS current rating should be greater than the inductor ripple current:

The input capacitor value should be 22μF or higher for normal operation. The capacitor can be electrolytic, tantalum or ceramic. The input capacitor should be placed as close as possible to the IC; if not possible, a 0.1μF decoupling ceramic capacitor between VIN pin and GND in close proximity.

Inductor

The inductor is used to supply higher output voltage when the NMOS switch is off. For a given input and output voltage, the inductance and switching frequency determine the inductor ripple current, defined as,

$$\Delta I_L = \frac{V_{OUT} - V_{IN}}{L} \times I_{OFFPULSE} \quad (\text{Eq. 2})$$

The peak inductor current is:

$$I_{Lpeak} = I_{IN} + \frac{\Delta I_L}{2} \quad (\text{Eq. 3})$$

Higher boost inductance will yield lower inductor ripple current but this will require an inductor with higher saturation current rating at the highest operating temperature. Lower ripple current helps to reduce inductor core losses. It also reduces RMS current through inductor, switch and freewheeling diode, which results in less conduction loss. The peak to peak ripple current of the inductor should be between 30% to 50% of input current. An inductor value of 10μH is recommended for 10 to 12 LED operation.

Output Capacitor

The output ripple voltage specification is key in the selection of the output capacitor. In a boost converter, the output ripple voltage is determined by load current, input voltage, output voltage, switching frequency, output capacitor value and ESR. It can be calculated by the equation below: The voltage rating of the output capacitor must be higher than the intended output boost voltage plus the output ripple voltage. Therefore some de-rating is required to ensure long term reliability.

$$\Delta V_O = I_{LED} \times \left(\frac{V_O}{V_{IN}} \times ESR_{CO} + \frac{\left(1 - \frac{V_{IN}}{V_{OUT}}\right)}{f \times C_{OUT}} \right) \quad (\text{Eq. 4})$$

$$f = \frac{V_{IN}}{V_{OUT} \times t_{OFF}} \quad (\text{Eq. 5})$$

where,

I_{LED} is the load current or LED current,

C_{OUT} is output capacitor value, and

ESR_{CO} is the Equivalent Series Resistor of output capacitor.

When low ESR ceramic output capacitors are used, the impedance of the capacitor at the switching frequency dominates. Output ripple is mainly caused by capacitor value and load current with the frequency, input and output voltage. The output ripple voltage calculation can be simplified to:

$$\Delta V_O = I_L \times \frac{\left(1 - \frac{V_{IN}}{V_{OUT}}\right)}{f \times C_{OUT}} \quad (\text{Eq. 6})$$

An output capacitor with the value of 10μF is usually sufficient to meet most applications requirements.

Output Boost Diode

A low forward drop Schottky with fast transit time should be selected to improve converter efficiency.

Its current rating should be higher than the peak current that commutates during its conduction interval. In addition, the rated breakdown voltage should be higher than the application boost voltage plus some margin of transient overshoot.

Loop Compensation

AOZ1960 employs constant off time control and does not require slope compensation. The right half plane zero that is often problematic in all most boost converters has no significant effect in the AOZ1960's frequency response. The RHP zero has the effect of a zero in the gain causing +20dB/decade on the roll off, but has the effect of a pole in the phase, subtracting 90° in the phase. The RHP zero can cause instability issues if the bandwidth is higher, therefore it is recommended to lower the bandwidth by one half frequency of the RHP zero.

The RHPZ can be calculated as follows:

$$f_{RHPZ} = \frac{D_P(I_{LOAD})^2 \times R_{OUT}(I_{LOAD})}{2\pi \times L} \quad (\text{Eq. 7})$$

where,

$$D_P(I_{LOAD}) = 1 - D(I_{LOAD}) \quad (\text{Eq. 8})$$

$$R_{OUT}(I_{LOAD}) = \frac{V_{OUT}(I_{LOAD})}{I_{LOAD}} \quad (\text{Eq. 9})$$

The cross over frequency in typical applications should be a fifth of the frequency of the RHPZ location.

$$f_{CROSS} = \frac{f_{RHPZ}}{5} \quad (\text{Eq. 10})$$

The objective of compensation is to shape the gain and phase of the converter's closed loop transfer function ultimately to achieve stability. The compensation pin of AOZ1960 serves as the output of the voltage transconductance error amplifier. In a typical application, a series capacitor and resistor network connected to the COMP pin creates the pole-zero compensation network enabling a very stable high-bandwidth control loop.

The closed loop transfer function:

$$H(w) = \frac{G_M \times R_{EA} \times \left(1 + \frac{s(w)}{w_z}\right)}{\left(1 + \frac{s(w)}{w_{p1}}\right)} \quad (\text{Eq. 11})$$

The corresponding pole is:

$$f_P = \frac{1}{2\pi \times R_{EA} \times C_{COMP}} \quad (\text{Eq. 12})$$

The corresponding zero is:

$$f_Z = \frac{1}{\frac{R_{COMP} \times R_{EA}}{R_{COMP} + R_{EA}} \times C_{COMP}} \quad (\text{Eq. 13})$$

where,

G_M is the error amplifier transconductance, which is $100\mu\text{A} / \text{V}$,

$R_{EA} = 5\text{M}\Omega$,

C_{COMP} is compensation capacitor,

R_{COMP} is compensation resistor.

A compensation resistor of $10\text{k}\Omega$ and compensation capacitor of 100nF .

Circuit Layout and Thermal management

To minimize unwanted noise and voltage transients, careful PCB layout must be exercised to reduce the main current loop areas. This optimization helps to reduce the switching noise associated with current commutation in the circuit and also helps to improve the efficiency of the converter. In addition to reducing the main power loops it is also important to keep sensitive nodes such as compensation and enable pins in quieter ground areas away from the main power ground connection.

In the AOZ1960 boost LED driver circuit, there are two main switching loops that pulsate current flow when the NMOS turns on and off. The first loop starts when the NMOS switches on, the input current or inductor current ramps positively through the inductor and NMOS device. During this interval, the output boost diode is reversed biased with its anode pulled low to ground. Since the NMOS is internal in the AOZ1960 much of the parasitic inductance is made from the power return to the ground connection of the input capacitors.

Based on the duty cycle arrangement, the controller will signal the internal driver to turn-off the NMOS to initiate the fixed off time. After the NMOS is fully off, the continuous inductor current continues to freewheel through the output boost diode. The key parasitics in this loop consist of PCB trace inductance from the anode to the LX connection and lastly the connection from cathode to power ground return. Both input and output capacitors should be ceramic in type to achieve low ESR and ESL specifications.

Below are some key tips in minimize the two main switching loops and improving noise immunity:

1. Maximized the copper area to the GND pin and the VIN pin for improved thermal dissipation.
2. Incorporate a ground plane on both top and bottom layers if possible.
3. To minimize trace inductance connects the device to the LX pin with a short wire and adoption of this technique for connections to the output capacitor and ground.
4. Add thermal vias for the GND pad for improved thermal dissipation between top and bottom layers.
5. To maximize thermal dissipation pour incorporate copper planes in unused areas.
6. Route sensitive signals such as OVP and COMP pins a far distance away from the LX switching node and pin.

In the AOZ1960 boost regulator circuit, the major power dissipating components are the AOZ1960 and output inductor. The total power dissipation of converter circuit can be measured by difference between the input and output power.

$$P_{total_loss} = (V_{IN} \times I_{IN}) - (V_O \times I_O) \quad (\text{Eq. 14})$$

The power dissipation of inductor can be approximately calculated by input current and DCR of inductor.

$$P_{inductor_loss} = I_{IN}^2 \times R_{inductor} \times 1.1 \quad (\text{Eq. 15})$$

The actual AOZ1960 junction temperature can be calculated with power dissipation and the thermal impedance from junction to ambient.

$$T_{junction} = (P_{total_loss} - P_{inductor_loss}) \times \Theta + T_{amb} \quad (\text{Eq. 16})$$

The maximum junction temperature of AOZ1960 is rated at 145°C. The thermal performance of the AOZ1960 is strongly affected by the PCB layout and proper care should be taken to ensure that the device will operate under the recommended environmental conditions.

Package Dimensions, DFN 7x4 24L EP3_S

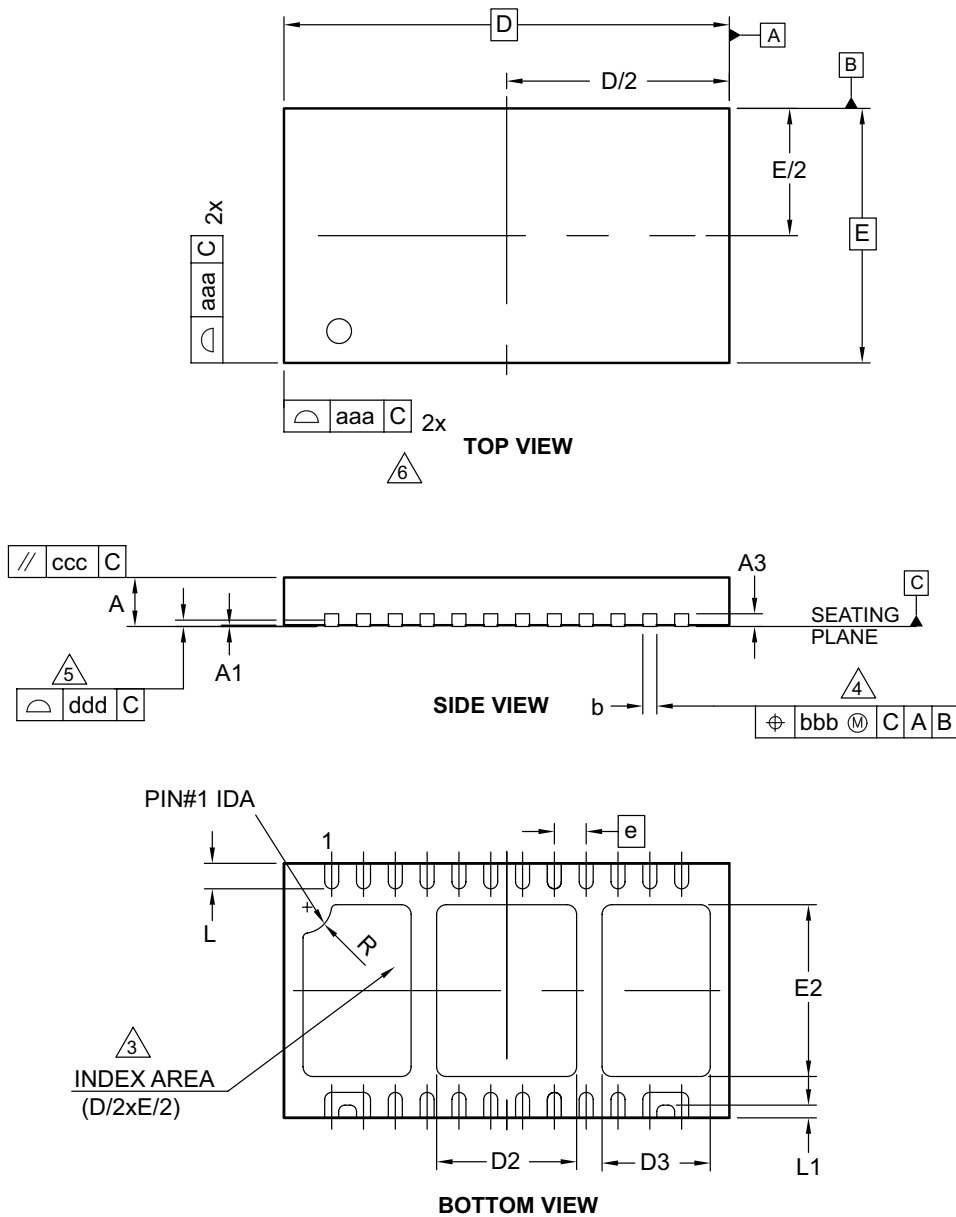

Note:

1. Dimensioning and tolerancing conform to ASME Y14.5M-1994.
2. All dimensions are in millimeters.
3. The location of the terminal #1 identifier and terminal numbering convention conforms to JEDEC publication 95 SPP-002.
4. Dimension b applies to metallized terminal and is measured between 0.15mm and 0.30mm from the terminal tip. If the terminal has the optional radius on the other end of the terminal, the dimension b should not be measured in that radius area.
5. Coplanarity applies to the terminals and all other bottom surface metallization.
6. Drawing shown are for illustration only.

Package Dimensions, DFN 7x4 24L EP3_S (Continued)

RECOMMENDED LAND PATTERN

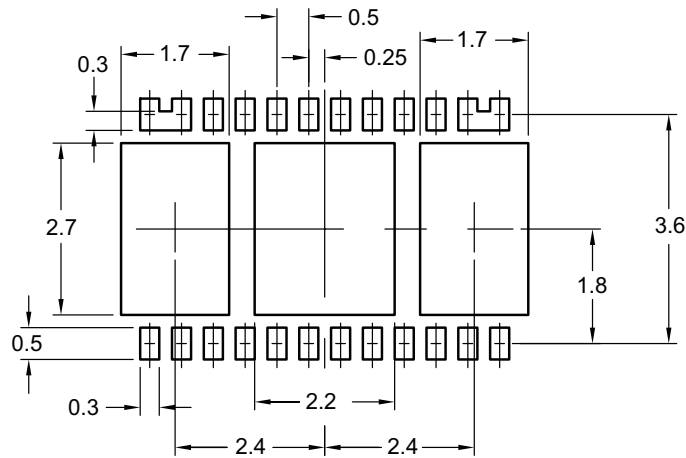

UNIT: mm

Dimensions in millimeters

Symbols	Min.	Nom.	Max.
A	0.80	0.90	1.00
A1	0.00	0.02	0.05
A3	0.20 REF		
b	0.17	0.25	0.35
D	7.00 BSC		
D2	1.975	2.200	2.225
D3	1.625	1.700	1.775
E	4.00 BSC		
E2	2.650	2.700	2.750
ⓔ	0.50 BSC		
L	0.300	0.400	0.500
L1	-	0.200	-
R	0.45 REF		
aaa	0.15		
bbb	0.10		
ccc	0.10		
ddd	0.08		

Dimensions in inches

Symbols	Min.	Nom.	Max.
A	0.031	0.035	0.039
A1	0.000	0.001	0.002
A3	0.008 REF		
b	0.007	0.010	0.014
D	0.276 BSC		
D2	0.078	0.087	0.088
D3	0.064	0.067	0.070
E	0.157 BSC		
E2	0.104	0.106	0.108
ⓔ	0.020 BSC		
L	0.012	0.016	0.020
L1	-	0.008	-
R	0.018 REF		
aaa	0.006		
bbb	0.004		
ccc	0.004		
ddd	0.003		

Tape and Reel Dimensions, DFN 7x4 24L EP3_S

Tape

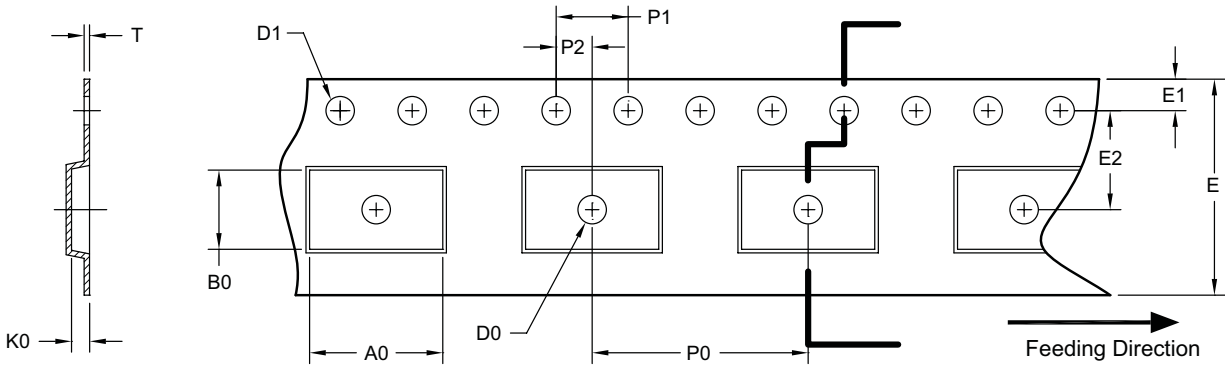

UNIT: MM

Package	A0	B0	K0	D0	D1	E	E1	E2	P0	P1	P2	T
DFN7x4 (12 mm)	7.4 ±0.1	4.4 ±0.1	1.0 ±0.1	1.55 ±0.05	1.55 ±0.05	12.0 ±0.3	1.75 ±0.10	5.5 ±0.1	12.0 ±0.1	4.0 ±0.1	2.0 ±0.1	0.30 ±0.05

Reel

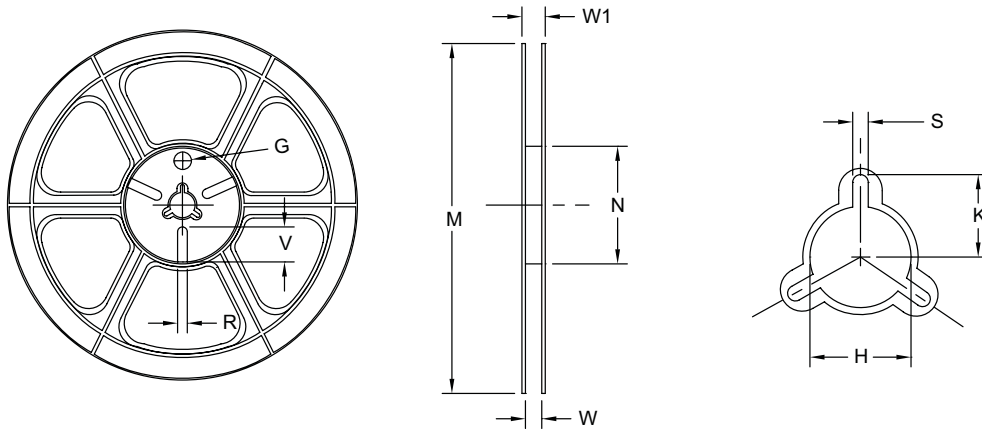

UNIT: MM

Tape Size	Reel Size	M	N	W	W1	H	K	S	G	R	V
12 mm	Ø330	Ø330 Max.	Ø100 Min.	12.4 +2.0 -0.0	18.4 Max.	Ø13.0 +0.5 -0.2	10.1 Min.	1.5 Min.	---	---	---

Leader/Trailer and Orientation

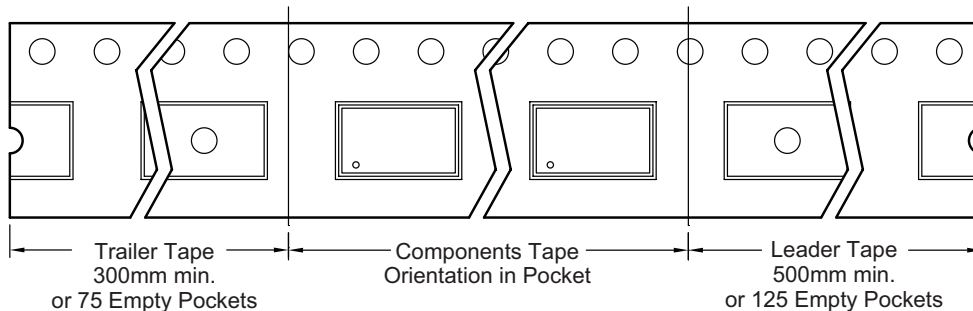

Part Marking

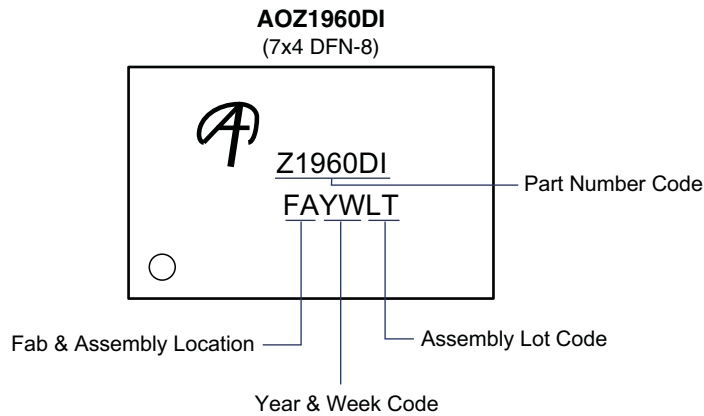

This data sheet contains preliminary data; supplementary data may be published at a later date. Alpha & Omega Semiconductor reserves the right to make changes at any time without notice.

LIFE SUPPORT POLICY

ALPHA & OMEGA SEMICONDUCTOR PRODUCTS ARE NOT AUTHORIZED FOR USE AS CRITICAL COMPONENTS IN LIFE SUPPORT DEVICES OR SYSTEMS.

As used herein:

- | | |
|---|---|
| <p>1. Life support devices or systems are devices or systems which, (a) are intended for surgical implant into the body or (b) support or sustain life, and (c) whose failure to perform when properly used in accordance with instructions for use provided in the labeling, can be reasonably expected to result in a significant injury of the user.</p> | <p>2. A critical component in any component of a life support, device, or system whose failure to perform can be reasonably expected to cause the failure of the life support device or system, or to affect its safety or effectiveness.</p> |
|---|---|