

---

*Fixed Frequency, 2 A Synchronous Buck Regulator  
With Fault Warnings and Power OK*

---

## **Discontinued Product**

This device is no longer in production. The device should not be purchased for new design applications. Samples are no longer available.

Date of status change: December 3, 2013

### **Recommended Substitutions:**

*For existing customer transition, and for new customers or new applications, contact Allegro Sales.*

---

NOTE: For detailed information on purchasing options, contact your local Allegro field applications engineer or sales representative.

---

*Allegro MicroSystems, LLC reserves the right to make, from time to time, revisions to the anticipated product life cycle plan for a product to accommodate changes in production capabilities, alternative product availabilities, or market demand. The information included herein is believed to be accurate and reliable. However, Allegro MicroSystems, LLC assumes no responsibility for its use; nor for any infringements of patents or other rights of third parties which may result from its use.*

---

## Fixed Frequency, 2 A Synchronous Buck Regulator With Fault Warnings and Power OK

### Features and Benefits

- High efficiency integrated FETs optimized for lower duty cycle voltage conversion: 180 mΩ high side, 40 mΩ low side
- Adjustable output voltage, down to 0.6 V
- Extremely short minimum controllable on-time; example: allows 12 V conversion to 0.6 V at >1 MHz
- Reference accuracy of  $\pm 1\%$  throughout temperature range
- FAULT and Power OK pins for operating and protection modes:
  - Normal operation
  - $V_{FB}$  low or high
  - Overcurrent
  - UVLO
  - Thermal warning prior to TSD
  - Thermal shutdown (TSD)
  - LX-GND short protection
  - Timing resistor open circuit protection

Continued on the next page...

**Package: 20-contact QFN with exposed thermal pad (suffix ES)**

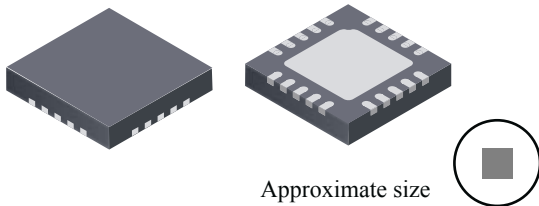

### Description

The A8670 is a synchronous buck converter capable of delivering up to 2 A. The A8670 utilizes valley current mode control, allowing very short on-times to be achieved. This makes it ideal for applications that require very low output voltages relative to the input voltage, combined with high switching frequencies. Valley current mode control inherently provides improved transient response over traditional switcher schemes, through the use of a voltage feedforward loop and frequency modulation during large signal load changes.

The A8670 includes a comprehensive set of diagnostic flags, allowing the host platform to react to a myriad of different conditions. A fault output indicates when either the temperature is becoming unusually high, or a single point failure has occurred; for example, the switching node (LX) shorted to ground, or the timing resistor going open-circuit. A Power OK (POK) output is also provided after a fixed delay, to indicate when the output voltage is within regulation. The A8670 is a rugged solution, offering protection against input undervoltages,

Continued on the next page...

### Applications

- Servers
- Point of load supplies
- Network and telecom
- Storage

### Typical Application Diagram

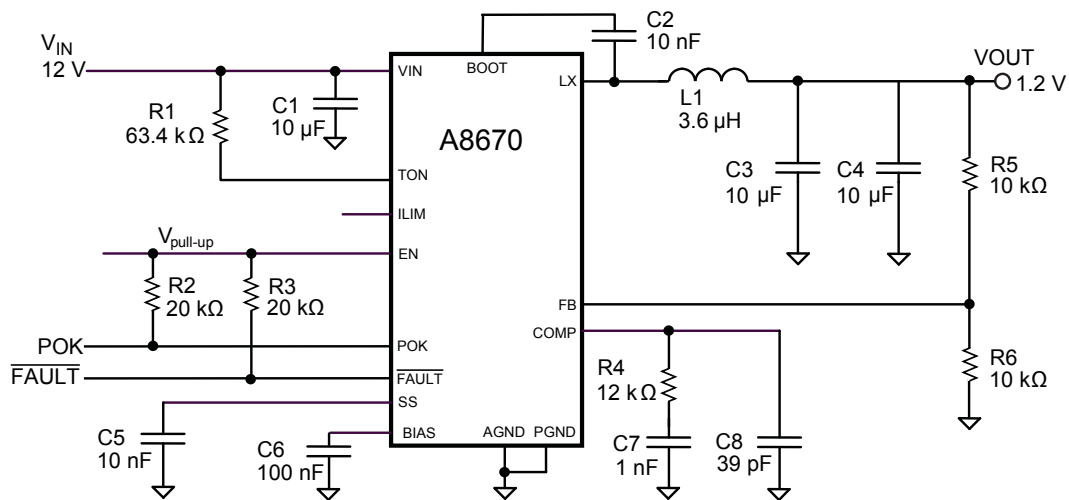

$V_{IN} = 12\text{ V}$ ,  $V_{OUT} = 1.2\text{ V}$ , and  $f_{SW} = 700\text{ kHz}$   
For additional examples, see the Typical Applications section

### Features and Benefits (continued)

- Adjustable switching frequency and current limit to optimize efficiency and external component sizing
- Externally adjustable soft-start time
- Shutdown supply current only 1  $\mu$ A
- Pre-bias start-up capability
- Input voltage range: from 7 to 16 V

### Description (continued)

output overvoltages, overtemperature, output overloads, short-circuits, current source overloads and any single point failures.

The A8670 is extremely flexible, with external loop compensation, on-time select (switching frequency), programmable soft-start, and current limit. The selectable pulse-by-pulse current limit avoids the requirement to oversize the inductor to cope with large fault currents. The switching frequency can be chosen, between 200 kHz and 1 MHz.

The device package (ES) is a 20-contact, 4 mm  $\times$  4 mm, 0.75 mm nominal overall height QFN with exposed thermal pad. The package is lead (Pb) free, with 100% matte tin leadframe plating.

### Selection Guide

Part Number	Packing*
A8670EESTR-T	7-in. reel, 1500 pieces/reel, 12-mm carrier tape

\*Contact Allegro™ for additional packing options



### Absolute Maximum Ratings

Characteristic	Symbol	Notes	Rating	Unit
VIN, TON, and EN Pin Voltage	$V_I$	With respect to GND	-0.3 to 18	V
LX Pin Voltage	$V_{LX}$	With respect to GND	-0.6 to $V_{IN} + 0.3$	V
		$t < 50$ ns, with respect to GND	-1.0	V
BOOT Pin Voltage	$V_{BOOT}$	With respect to GND	$V_{LX} - 0.3$ to $V_{LX} + 8.0$	V
BIAS Pin Voltage	$V_{BIAS}$		-0.3 to 8.0	V
All Other Pins	-		-0.3 to 7.0	V
Operating Ambient Temperature	$T_A$	E temperature range	-40 to 85	°C
Maximum Junction Temperature	$T_J(max)$		150	°C
Storage Temperature	$T_{stg}$		-55 to 150	°C

### Table of Contents

Functional Block Diagram	3	Soft-Start and Output Overloads	10
Pin-out Diagram and Terminal List	4	Fault Handling and Reporting	11
Functional Description	7	Control Loop	13
Basic Operation	7	Control Loop Design Approach	14
Output Voltage Selection	7	Thermal Considerations	17
Switch On-Time and Switching Frequency	7	Regulator Efficiency	18
Inductor Selection	8	Layout	19
Output Capacitor Selection	9	Typical Applications	20
Input Capacitor Selection	9	Package Outline Drawing	26

### Functional Block Diagram

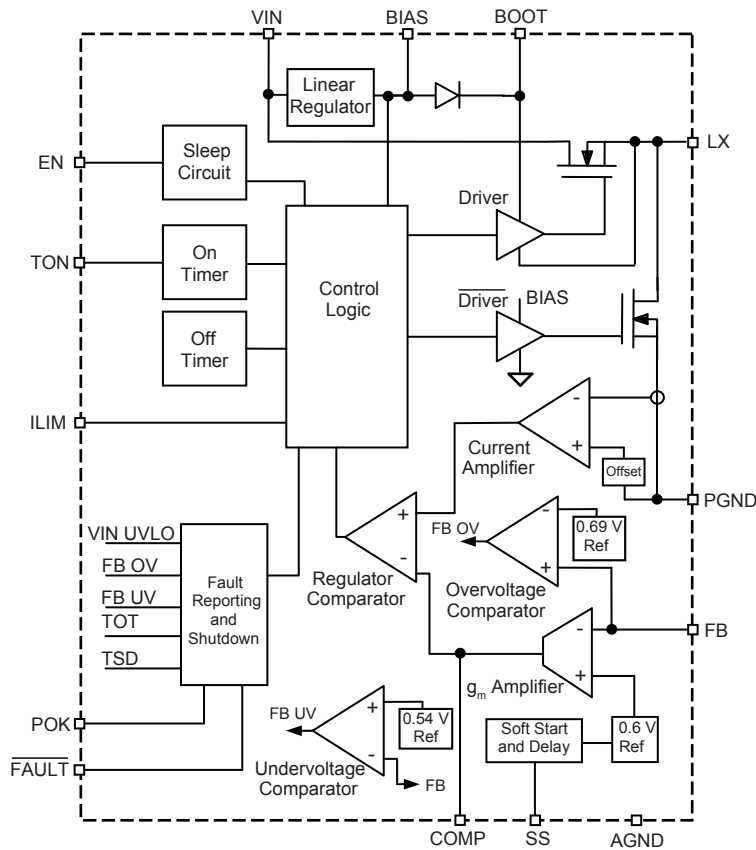

**Thermal Characteristics** may require derating at maximum conditions, see application information

Characteristic	Symbol	Test Conditions*	Value	Unit
Package Thermal Resistance (Junction to Ambient)	$R_{\theta JA}$	On 4-layer PCB based on JEDEC standard	37	°C/W
Package Thermal Resistance (Junction to Pad)	$R_{\theta JP}$		2	°C/W

\*Additional thermal information available on the Allegro website

Pin-out Diagram

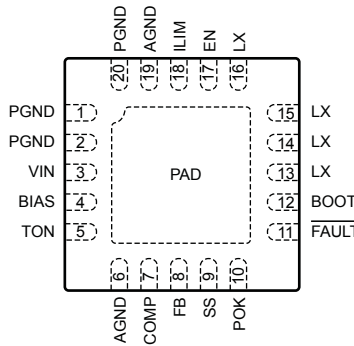

Terminal List Table

Number	Name	Function
1,2,20	PGND	Power ground. Connect to common ground.
3	VIN	Power input for the control circuits and the drain of the internal high-side MOSFET. This pin must be locally bypassed (see Typical Applications section circuit diagrams).
4	BIAS	Internal bias decoupling capacitor. Refer to the see Typical Applications section circuit diagrams, for recommended capacitors.
5	TON	On-Time pin. The resistor connected between this pin and VIN defines the on-time of the regulator. This in turn defines the switching frequency for a given output voltage.
6,19	AGND	Analog ground. Connect to common ground. This pin should be used as the FB resistor divider ground reference for optimal accuracy (see Typical Applications section circuit diagrams).
7	COMP	Output of the error amplifier and compensation node. Connect a series R-C network from this pin to GND for control loop regulation.
8	FB	Feedback input pin of the error amplifier. Connect a resistor divider from the converter output voltage node, VOUT, to this pin to set the converter output voltage.
9	SS	Soft-start ramp pin. The capacitor connected to this pin defines the rate of rise of the output voltage and the effective inrush current.
10	POK	Open drain Power Okay (power good) output. This pin will be a logic low if any fault (as defined in table 3) occurs, other than an overtemperature condition ( $T_J > 140^\circ\text{C}$ ).
11	$\overline{\text{FAULT}}$	Open drain $\overline{\text{FAULT}}$ output. This pin will be logic low if the on-time exceeds a certain value, if the LX node is shorted to ground, or if the thermal shutdown threshold has been reached ( $T_J > 160^\circ\text{C}$ ). See table 3.
12	BOOT	High-side gate drive supply input. This pin supplies the drive for the high-side switching MOSFET switch. Connect a 10 nF ceramic bootstrap capacitor between BOOT and LX.
13,14,15,16	LX	The source of the internal high-side switching MOSFET. The output inductor and BOOT capacitor should be connected to this pin (see Typical Applications section circuit diagrams).
17	EN	Enable pin. This pin is a logic input that turns the converter on or off. When $\text{EN} > V_{\text{ENHI}}$ , the part turns on.
18	ILIM	Pulse-by-pulse current limit setting. Leave this pin unconnected for maximum current from the regulator, or set this pin to GND for 50% current reduction.
–	PAD	Exposed pad of the package provides both electrical contact to the ground and good thermal contact to the PCB. This pad must be soldered to the PCB for proper operation and should be connected to the ground plane by through-hole vias. See Layout section for further details.

**ELECTRICAL CHARACTERISTICS**<sup>1</sup> Valid at  $T_J = -20^\circ\text{C}$  to  $125^\circ\text{C}$  and  $V_{IN} = 12\text{ V}$ ; unless otherwise specified

Characteristics	Symbol	Test Conditions	Min.	Typ.	Max.	Unit
<b>General</b>						
Input Voltage Range	$V_{IN}$		7	–	16	V
Input Quiescent Current	$I_{IN}$	$V_{EN} = 5\text{ V}$ , $V_{FB} = 1.2\text{ V}$ , no switching	–	–	4	mA
		$V_{IN} = 16\text{ V}$ , $V_{EN} = 0\text{ V}$	–	1	10	$\mu\text{A}$
Feedback Voltage	$V_{FB}$	$7.0\text{ V} \leq V_{IN} \leq 16\text{ V}$ , $V_{FB} = V_{COMP}$	0.594	0.600	0.606	V
Maximum Switching Frequency	$f_{sw(max)}$		–	1000	–	kHz
Minimum Switching Frequency	$f_{sw(min)}$		–	200	–	kHz
On-Time Tolerance	$\Delta t_{on}$	$R_{TON} = 60\text{ k}\Omega$	–10	–	10	%
Maximum On-Time Period	$t_{on(max)}$		2.5	3.5	4.5	$\mu\text{s}$
Minimum On-Time Period	$t_{on(min)}$		–	50	90	ns
Minimum Off-Time Period	$t_{off(min)}$		–	–	350	ns
High-Side MOSFET On-Resistance	$R_{DS(on)HS}$	$I_{DS} = 0.2\text{ A}$	–	180	–	m $\Omega$
High-side MOSFET Leakage Current <sup>2</sup>	$I_{lkgHS}$	$V_{DS} = 12\text{ V}$ , EN = low	–	–	2	$\mu\text{A}$
Low-side MOSFET On-Resistance	$R_{DS(on)LS}$	$I_{DS} = 0.2\text{ A}$	–	40	–	m $\Omega$
Low-side MOSFET Leakage Current <sup>2</sup>	$I_{lkgLS}$	$V_{DS} = 12\text{ V}$ , EN = low	–	–	3	$\mu\text{A}$
Soft Start Source Current <sup>2</sup>	$I_{SS}$	$V_{SS} > V_{SSPWM}$	–	–10	–	$\mu\text{A}$
Soft Start Threshold	$V_{SSPWM}$	$V_{SS}$ rising	–	600	–	mV
Soft Start Ramp Time	$t_{SS}$	$C_{SS} = 10\text{ nF}$	–	600	–	$\mu\text{s}$
<b>Amplifier and Power Stage Gain</b>						
Feedback Input Bias Current <sup>2</sup>	$I_{FB}$	$V_{FB} = 0.6\text{ V}$	–	$\pm 50$	$\pm 250$	nA
Error Amplifier Open Loop Voltage Gain	$A_{VEA}$		–	61	–	dB
Error Amplifier Transconductance	$g_{mCOMP}$	$I_{COMP} = \pm 20\text{ }\mu\text{A}$	600	800	1000	$\mu\text{A/V}$
Error Amplifier Maximum Source/Sink Current <sup>2</sup>	$I_{COMP(max)}$	$V_{FB} = V_{FB0} \pm 0.4\text{ V}$	–	$\pm 52$	–	$\mu\text{A}$
COMP Voltage to Current Gain	$g_{mPOWER}$		–	1.3	–	A/V
<b>Enable</b>						
Enable High Threshold	$V_{ENHI}$		1.8	–	–	V
Enable Low Threshold	$V_{ENLO}$		–	–	0.8	V
Enable Hysteresis	$V_{ENHYS}$		150	250	–	mV
Enable Current <sup>2</sup>	$I_{EN}$	$V_{EN} = 3.3\text{ V}$	–	50	–	$\mu\text{A}$

Continued on the next page...

**ELECTRICAL CHARACTERISTICS<sup>1</sup>** (continued) Valid at  $T_J = -20^\circ\text{C}$  to  $125^\circ\text{C}$  and  $V_{IN} = 12\text{ V}$ ; unless otherwise specified

Characteristics	Symbol	Test Conditions	Min.	Typ.	Max.	Unit
<b>Fault Reporting and Power OK</b>						
Undervoltage Threshold (Rising)	$POK_{HI}$	Feedback voltage relative to reference voltage, POK = high	85	90	95	%
Undervoltage Hysteresis	$POK_{HYS}$	POK = low	–	5	–	%
Overshoot Threshold (Rising)	$POK_{LO}$	Feedback voltage relative to reference voltage, POK = low	110	115	120	%
POK Rising Delay	$POK_{delay}$		–	90	–	$\mu\text{s}$
$\overline{\text{FAULT}}$ Overtemperature	$T_{OT}$	Temperature rising	–	140	–	$^\circ\text{C}$
$\overline{\text{FAULT}}$ Overtemperature Hysteresis	$T_{OTHYS}$	Fault release = $T_{OT} - T_{OTHYS}$	–	20	–	$^\circ\text{C}$
POK and $\overline{\text{FAULT}}$ Output Voltage	$V_{POK}$	$I_{POK} = 10\text{ mA}$ , fault asserted	–	–	500	mV
Minimum $V_{IN}$ for correct operation of POK and $\overline{\text{FAULT}}$	$V_{INPOK}$	POK and $\overline{\text{FAULT}}$ pull-up of 2 k $\Omega$ to 5 V	–	3.5	–	V
POK and $\overline{\text{FAULT}}$ Leakage <sup>2</sup>	$I_{POK}$	$V_{POK} = 5.5\text{ V}$ , fault not asserted	–	–	1	$\mu\text{A}$
<b>Protection</b>						
Pulse-by-Pulse Valley Current Limit	$I_{LIM}$	ILIM = open	2.1	2.7	3.3	A
		ILIM = GND	1.0	1.30	1.6	A
Hiccup Overload Duration	$t_{HICOC}$	Valley current limit reached	–	50	–	$\mu\text{s}$
Hiccup Shutdown Duration	$t_{HICSD}$		–	300	–	$\mu\text{s}$
Pulse-by-Pulse Negative Valley Current Limit	$I_{NLIM}$	Load acting as a current source	–700	–	–500	mA
High-Side Switch Protection Current	$I_{HIPRO}$	LX node short-circuited to GND	–	9	–	A
High-Side Switch Protection Voltage	$V_{HIPRO}$	LX node short-circuited to GND	1.8	2.0	2.2	V
$V_{IN}$ Undervoltage Lockout	$V_{UVLO}$	$V_{IN}$ rising	6.0	6.4	6.8	V
$V_{IN}$ Undervoltage Lockout Hysteresis	$V_{UVLOHYS}$		–	400	–	mV
Thermal Shutdown Threshold	$T_{SD}$	Temperature rising	–	160	–	$^\circ\text{C}$
Thermal Shutdown Hysteresis	$T_{SDHYS}$	Recovery = $T_{SD} - T_{SDHYS}$	–	15	–	$^\circ\text{C}$

<sup>1</sup>Specifications throughout the junction temperature,  $T_J$ , range of  $-20^\circ\text{C}$  to  $125^\circ\text{C}$  are assured by design and characterization unless otherwise noted.

<sup>2</sup>Positive current is into the node or pin, negative current is out of the node or pin.

## Functional Description

### Basic Operation

At the beginning of a switching cycle, the high-side switch is turned on for a duration determined by the current flowing into TON. The magnitude of current is determined by the value of the input voltage and the value of the on-time resistor (RTON, R1 in the Typical Applications section circuit diagrams).

During the on-time period, the current builds up through the inductor at a rate determined by the voltage developed across it and the inductance value. When the on-time period elapses, the output of an RS latch resets, turning off the high-side switch. After a small dead-time delay, the low-side switch is turned on.

The current through the inductor decays at a rate determined by the output voltage and the inductance value. The current is sensed through the low-side switch and is compared to the *current demand signal*. The current demand signal is generated by comparing the output voltage (stepped down to the FB pin) with an accurate reference voltage.

When the current through the low-side switch drops to the current demand level, the low-side switch is turned off. After a further dead-time delay, the high-side switch is turned on again, and the process is repeated.

### Output Voltage Selection

The output voltage ( $V_{OUT}$ ) of the converter is set by selecting the appropriate feedback resistors using the following formula:

$$V_{OUT} = V_{FB} \times \left( \frac{R_5}{R_6} + 1 \right) + I_{FB} \times \frac{R_5 \times R_6}{R_5 + R_6} \quad (1)$$

where:

$V_{FB}$  is the reference voltage,

R5 and R6 are as shown in the Typical Applications section circuit diagrams, and

$I_{FB}$  is the reference bias current.

It is important to consider the tolerance of the feedback resistors, because they directly affect the overall setpoint accuracy of the output voltage.

It is also important to consider the actual resistor values selected and consider the trade-offs. High value resistors will minimize the shunt current flowing through the feedback network, enhancing efficiency. However, the offset error produced by the refer-

ence bias current will increase, affecting the regulation. In addition, high value resistors are more prone to noise pick-up effects which may affect performance. As some kind of compromise, it is recommended that R6 be in the region of 10 k $\Omega$ .

### Switch On-Time and Switching Frequency

The switching frequency of the converter is selected by choosing the appropriate on-time. The on-time can be estimated to a first order by using the following formula:

$$t_{on} = \frac{V_{OUT}}{V_{IN}} \times \frac{1}{f_{SW}} \quad (2)$$

where:

$V_{OUT}$  is the output voltage,

$f_{SW}$  is the switching frequency, and

$V_{IN}$  is the nominal input voltage.

To factor-in the effects of resistive voltage drops in the converter circuit, the following formula can be used to produce a more accurate estimate of what the on-time has to be for a required switching frequency:

$$t_{on} = \frac{V_{OUT} + (R_{DS(on)LS} + DCR_L) \times I_{OUT}}{V_{IN} + (R_{DS(on)LS} - R_{DS(on)HS}) \times I_{OUT}} \times \frac{1}{f_{SW}} \quad (3)$$

where:

$R_{DS(on)LS}$  is the low-side MOSFET on-resistance,

$R_{DS(on)HS}$  is the high-side MOSFET resistance, and

$DCR_L$  is the inductive resistance.

The switching frequency will vary slightly as the resistive voltage drops in the circuit change, either due to temperature effects or to input voltage variations.

Note that when selecting the switching frequency, care should be taken to ensure the converter does not operate near either the minimum on-time (50 ns) or the minimum off-time (350 ns). Minimum on-times will typically occur in combinations of maximum input voltage, minimum output voltage with minimum load, and maximum switching frequency. Minimum off-times will typically occur in combinations of minimum input voltage, maximum output voltage with maximum load, and maximum switching frequency.



The  $t_{on}$  from either of the above formulae can be used to determine the TON resistor value,  $R_{TON}$  (R1 in Typical Applications section circuit drawings):

$$R_{TON} = (V_{IN} - 0.67) \times \frac{t_{on} - 8 \times 10^{-9}}{25 \times 10^{-12}} - 500 \quad (4)$$

Table 1 provides preferred resistor values for a given output voltage at target switching frequencies of 500 kHz, 700 kHz, and 1 MHz:

**Table 1. Recommended RTON Resistor Values**

Switching Frequency, $f_{SW}$					
500 kHz		700 kHz		1 MHz	
$V_{OUT}$ (V)	$R_{TON}$ (k $\Omega$ )	$V_{OUT}$ (V)	$R_{TON}$ (k $\Omega$ )	$V_{OUT}$ (V)	$R_{TON}$ (k $\Omega$ )
5.0	374	5.0	267	5.0	182
3.3	243	3.3	174	3.3	121
2.5	187	2.5	133	2.5	90.9
1.8	137	1.8	95.9	1.8	64.9
1.5	113	1.5	80.6	1.5	54.9
1.2	90.9	1.2	63.4	1.2	43.2
1.0	76.8	1.0	52.3	1.0	35.7
0.8	60.4	0.8	42.2	0.8	28.7
0.6	44.2	0.6	30.9	0.6	23.2

### Inductor Selection

The main factor in selecting the inductance value is the ripple current. The ripple current affects the output voltage ripple and current limit. A reasonable figure of merit for the ripple current ( $I_{ripp}$ ) is 25% of the maximum load. So for a maximum load of 2 A, the peak-to-peak ripple current should be 500 mA.

The maximum peak-to-peak ripple current occurs at the maximum input voltage. To a reasonable approximation, the minimum duty cycle can be found:

$$D(\min) = \frac{V_{OUT}}{V_{IN}(\max)} \quad (5)$$

The required (minimum) inductance can be found:

$$L(\min) = \frac{V_{IN} - V_{OUT}}{I_{ripp}} \times D(\min) \times \frac{1}{f_{SW}} \quad (6)$$

Note that the inductor manufacturer tolerances on the inductance value should be taken into account. This can be as high as  $\pm 30\%$ .

It is recommended that gapped ferrite solutions be used as opposed to powdered iron solutions. This is because powdered iron cores exhibit relatively high core losses, especially at higher switching frequencies. Higher core losses do have a detrimental impact on the long term reliability of the component.

Inductors are typically specified at two current levels:

- **Saturation Current ( $I_{sat}$ )** The worst case maximum peak current should not exceed the saturation current and indeed some margin should be allowed. The maximum peak current in an inductor occurs during an overload condition where the circuit operates in current limit. The typical valley current limit ( $I_{LIM}$ ) is 2.7 A. The peak current through the inductor is effectively the valley current limit plus the ripple current:

$$I_{sat} > I_{LIM} + I_{ripp} \quad (7)$$

- **Rms Current ( $I_{rms}$ )** It is important to understand how the rms current level is specified in terms of ambient temperature. Some manufacturers quote an ambient whilst others quote a temperature that includes a self-temperature rise. For example, if an inductor is rated for 85°C and includes a self-temperature rise of 25°C at maximum load, then the inductor cannot be safely operated beyond an ambient temperature of 60°C at full load.

The rms current through the inductor should not exceed the rating for the inductor, taking into account the maximum ambient temperature. The maximum rms current is effectively the valley current limit ( $I_{LIM}$ ) plus half of the ripple current:

$$I_{rms}(\max) > I_{LIM} + I_{ripp} / 2 \quad (8)$$

A final consideration in the selection of the inductor is the series resistance (DCR). A lower DCR will reduce the power loss and enhance power efficiency. The trade-off in using an inductor with a relatively low DCR is the physical size is typically larger.

Recommended inductors include the NR8040 or NR6045 series manufactured by Taiyo Yuden.

Table 2 provides preferred inductor values for a given output voltage, 2 A output at target switching frequencies of 500 kHz, 700 kHz, and 1 MHz.

**Table 2. Recommended Inductor Values**

Switching Frequency, $f_{SW}$					
500 kHz		700 kHz		1 MHz	
$V_{OUT}$ (V)	L ( $\mu$ H)	$V_{OUT}$ (V)	L ( $\mu$ H)	$V_{OUT}$ (V)	L ( $\mu$ H)
5.0	10	5.0	10	5.0	6.8
3.3	10	3.3	6.8	3.3	4.7
2.5	10	2.5	4.7	2.5	3.6
1.8	6.8	1.8	4.7	1.8	3.6
1.5	4.7	1.5	3.6	1.5	3.6
1.2	4.7	1.2	3.6	1.2	2
1.0	3.6	1.0	2	1.0	2
0.8	3.6	0.8	2	0.8	1.4
0.6	2	0.6	1.4	0.6	0.9

### Output Capacitor Selection

The output capacitor has two main functions: influence the control loop response (see the Control Loop section), and determine the magnitude of the output voltage ripple.

The output voltage ripple can be approximated to:

$$V_{ripp} = \frac{I_{ripp}}{8 \times f_{SW} \times C_{OUT}} \quad (9)$$

where:

$I_{ripp}$  is the peak-to-peak current in the inductor (see the Inductor Selection section), and

$C_{OUT}$  is the output capacitance.

It is recommended that ceramic capacitors be used, taking into account: size, cost, reliability, and performance. It is imperative that ceramic type X5R or X7R are used. On no account should Y5V, Y5U, Z5U, or similar be used, because the capacitance tolerance and the temperature stability is very poor.

There is generally no need to consider the effects of heating caused by the ripple current flowing into the output capacitor. This is because the equivalent series resistance (ESR) of ceramic capacitors is extremely low.

When using ceramic capacitors, it is important to consider the effects of capacitance reduction due to the E-field. To avoid this voltage bias effect, it is recommended that the capacitor rated voltage be at least twice that of the actual output voltage. So for example, with a 5 V output, the capacitor should be rated to 10 V.

For the majority of applications, a 20  $\mu$ F output capacitor is recommended.

### Input Capacitor Selection

The function of the input capacitor is to provide a low impedance shunt path for the current drawn by the A8670 when the high-side switch is on. This minimizes the amount of ripple current reflected back into the source supply. This reduces the potential for higher conducted electromagnetic interference (EMI).

In a correctly designed system, with a quality capacitor positioned adjacent to the VIN pin and the PGND pin, this capacitor should supply the high-side switch current minus the average input current. During the high-side switch off-cycle, the capacitor is charged by the average input current.

The effective rms current that flows in the input filter capacitor is:

$$I_{rms} = \frac{V_{OUT} \times I_{OUT}}{V_{IN}} \times \left( \frac{V_{IN}}{V_{OUT}} - 1 \right)^{1/2} \quad (10)$$

The amount of ripple voltage ( $V_{ripp}$ ) that appears across the input terminals (VIN with respect to GND) is determined by the amount of charge removed from the input capacitor during the high-side switch conduction time. If a capacitor technology such as an electrolytic is used, then the effects of the ESR should also be taken into account.

The amount of input capacitance ( $C_{IN}$ ) required for a given ripple voltage can be found:

$$C_{IN} = \frac{I_{rms} \times t_{on}}{V_{ripp}} \quad (11)$$

where:

$t_{on}$  is the on-time of the high-side switch (see the Switch On-Time and Switching Frequency section; note that maximum  $t_{on}$  occurs at minimum input voltage), and

$C_{IN}$  is the input filter capacitance.

As mentioned in the Output Capacitor Selection section, the effects of voltage biasing should be taken into account when choosing the capacitor voltage rating. If ceramic capacitors are being used, then there is generally no need to consider the effects of ESR heating.

### Soft-Start and Output Overloads

The soft-start routine controls the rate of rise of the reference voltage, which in turn controls the FB pin, and thereby the output voltage ( $V_{OUT}$ ) (see figure 1). This function minimizes the amount of inrush current drawn from the input voltage ( $V_{IN}$ ) and potential voltage overshoot on the output rail ( $V_{OUT}$ ).

A soft-start routine is initiated when the enable pin (EN) is high, no overvoltage exists on the output, the thermal protection circuitry is not activated, and  $V_{IN}$  is above the undervoltage threshold. Immediately after EN goes high, the soft-start capacitor is charged via an internal 10  $\mu$ A source and PWM switching action occurs. During the *Soft-Start Ramp Time* (see A in figure 1), the reference is ramped from 0 up to 0.6 V, and the output voltage ( $V_{OUT}$ ) tracks the reference voltage. The POK flag is held low until the output voltage reaches 90% (typical) of the target voltage and a delay of 90  $\mu$ s (typical) occurs.

When an output overcurrent event occurs, the regulator immediately limits the valley current at a constant level on a pulse-by-pulse basis. The output voltage will tend to fold back, depending on how low the output impedance is. When the output voltage

drops below 85% (typical) of the target voltage, the POK flag goes low. If the overload occurs for shorter than the *Hiccup Overload Duration* (<50  $\mu$ s; B in figure 1), the output will automatically recover to the target level. If the overload occurs for longer than the *Hiccup Overload Duration* (>50  $\mu$ s; C in figure 1), the regulator will shut down, the soft-start capacitor will be discharged, and (assuming no other fault conditions exist and the enable pin is still high) the regulator will be delayed by the *Hiccup Shutdown Duration* (D in figure 1).

The Hiccup Shutdown Duration ensures that prolonged overload conditions do not cause excessive junction temperatures to occur. After the Hiccup Shutdown Duration has elapsed, the output voltage is again brought up, controlled by the soft-start function. However, if the overload condition still exists and still remains after the Soft-Start Ramp Time has elapsed, the regulator will shut down and the process will repeat until the fault is removed.

The Soft-Start Ramp Time,  $t_{SS}$ , can be found from the following formula:

$$t_{SS} = \frac{C_{SS} \times 0.6}{10 \times 10^{-6}} \quad (12)$$

where  $C_{SS}$  is C5 in the Typical Applications section circuit diagrams.

Although the A8670 is optimized for ceramic output capacitors, large value electrolytic capacitors can be used where either special hold-up, or power sequencing is required. Note the guidelines for selecting large value capacitors in the Control Loop section.

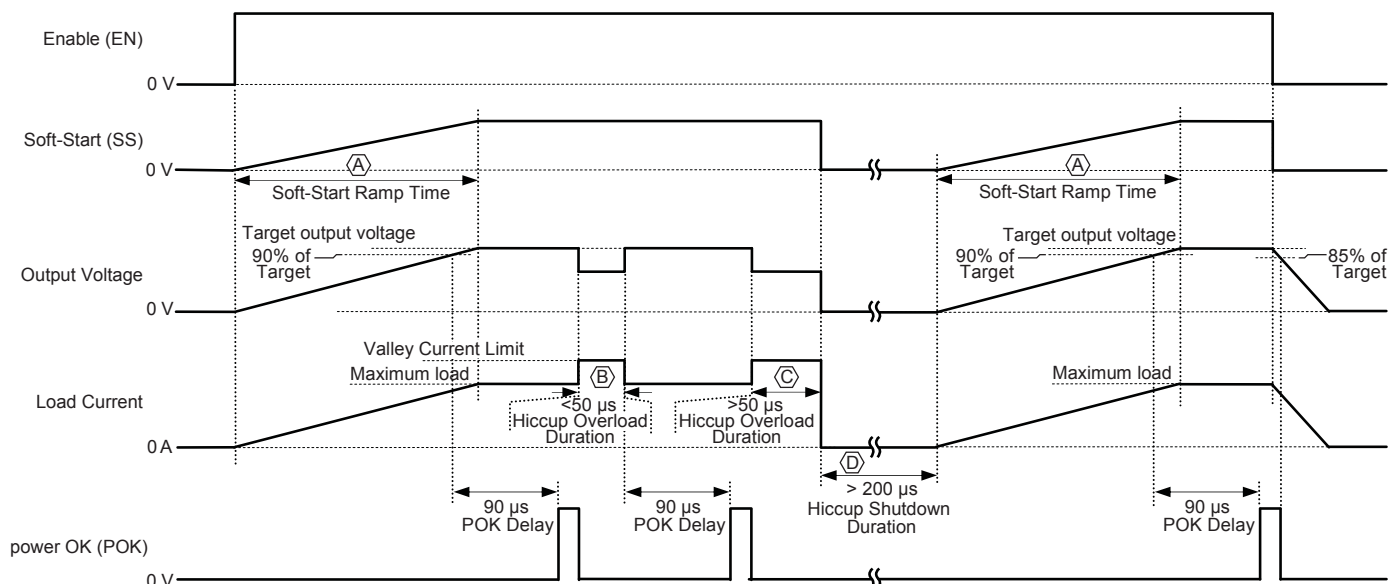

Figure 1. Operation of the soft-start function

When selecting larger-value output capacitors, it is important that the soft-start period is appropriately scaled to take into account the charging of these capacitors. For example, if the soft-start is optimized for a 22  $\mu\text{F}$  ceramic output capacitor and a 2000  $\mu\text{F}$  capacitor is added to the output, there is every possibility that the converter will remain in an overload condition after the soft-start and the Hiccup Overload Duration have elapsed. This mode of operation could prevent the output ever reaching the target output voltage.

To demonstrate the above, consider the following example: a regulator programmed for a 5 V output, 20  $\mu\text{F}$  output capacitor, and a soft-start time-off of 1 ms.

Assume there is no load current draw until 5 V is reached. At start-up, the regulator has to charge the output capacitor. From  $C \times V = I \times t$ , the charging current into the capacitor is:

$$I = 20 \mu\text{F} \times 5 / 1 \text{ ms} = 100 \text{ mA}$$

Now if a 2000  $\mu\text{F}$  capacitor is added to the output, the capacitor would require a charge current of:

$$I = 2000 \mu\text{F} \times 5 / 1 \text{ ms} = 10 \text{ A}$$

In this condition, the A8670 would run into the pulse-by-pulse current limit, limiting the average charge current to 2.9 A (typ). An average current of 2.9 A, assumes a valley current limit of 2.7 A and a half ripple current of 0.2 A. This means that after the soft-start delay of 1 ms, the output voltage would only be charged to:

$$V = 2.9 \text{ A} \times 1 \text{ ms} / 2000 \mu\text{F} = 1.45 \text{ V}$$

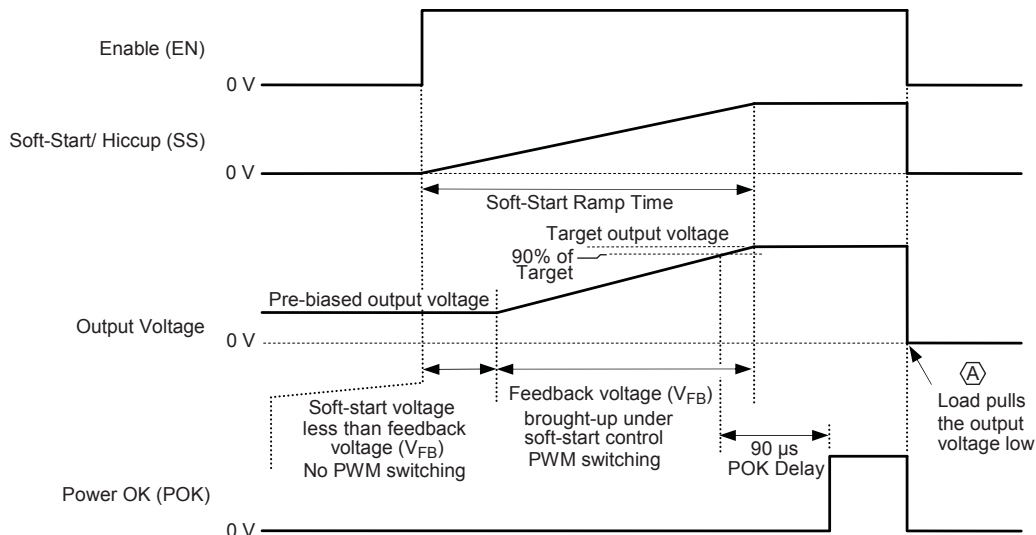

Figure 2. Operation of the soft-start function with pre-biasing

After the soft-start period is completed, the output capacitor would be charged for a short duration, defined by the Hiccup Overload Duration. Then the converter would shut down and, after the Hiccup Shutdown Duration had elapsed, would enter the start-up process again. This mode is highly undesirable and a more appropriate soft-start capacitor should be selected.

The effects of adding an output capacitor with too-large value would be a condition similar to starting-up into a short-circuit across the output; where the regulator enters a hiccup mode of operation.

If the output of the A8670 is pre-biased at start-up, the switcher will remain in a high impedance state until the soft-start has reached the feedback voltage ( $V_{FB}$ ) amplitude. This avoids the output voltage being discharged. After the soft-start threshold exceeds the FB pin voltage, PWM switching action occurs and the output voltage is brought up under the control of the soft-start circuit (see figure 2).

Note that when the regulator is turned off, it enters a high impedance mode (all switches off) and if the output voltage is discharged it is done so by the load (at A in figure 2). If the load does not discharge the output, the output voltage remains in a pre-biased condition.

### Fault Handling and Reporting

Table 3 describes the action taken for particular faults including the status of the  $\overline{\text{FAULT}}$  and POK flags.

**Table 3. Fault Handling and Reporting**

A8670 Condition	Comments	POK Flag	FAULT Flag	Action After Fault
$90\% < V_{FB} < 115\%$	Normal operation	High	High	–
$V_{FB} < 85\%$	During start-up, the feedback voltage ( $V_{FB}$ ) is brought-up under control of the soft-start circuit	Low	High	–
	After start-up, if an overload occurs for less than the Hiccup Overload Duration (50 $\mu$ s), the regulator will maintain switching operation	Low	High	Auto-recovery
	After start-up, if an overload occurs for greater than the Hiccup Overload Duration (50 $\mu$ s), the regulator will turn off and initiate a soft-start cycle	Low	High	Auto-restart under control of soft-start
$V_{FB} > 115\%$ No current sourced from load into regulator output	Regulator immediately turns off; when $V_{FB}$ is reduced to within regulation range, normal operation will resume	Low	High	Auto-recovery
$V_{FB} > 115\%$ Current sourced from load into regulator output	Regulator continues to operate, controlling to the Negative Valley Current Limit ( $I_{NLIM}$ ), –600 mA (typ); if the source current from the load increases beyond the current limit level, although the current limit level still holds, current will flow from the load to the input, perhaps resulting in an increase in input voltage	Low	High	Auto-recovery
$V_{IN} < 6$ V (typ)	Regulator immediately turns off	Low	High	Auto-restart under control of soft-start, when $V_{IN} > 6.4$ V (typ)
$T_J > 140^\circ\text{C}$ (typ)	Regulator keeps operating; if $T_J < 120^\circ\text{C}$ (typ), FAULT goes high	High	Low	–
$T_J > 160^\circ\text{C}$ (typ)	Regulator immediately turns off	Low	Low	Auto-restart under control of soft-start, when $T_J < 145^\circ\text{C}$
LX pin shorted to GND	The voltage across the series switch is monitored; if the voltage exceeds 2 V (typ), the regulator is latched off	Low	Low	Either the Enable pin (EN) or input voltage ( $V_{IN}$ ) must go low then high to restart under control of soft-start
$t_{on} > 4$ $\mu$ s (typ)	Regulator immediately turns off	Low	Low	Either the Enable pin (EN) or input voltage ( $V_{IN}$ ) must go low then high to restart under control of soft-start
Internal bias or bootstrap supply below the undervoltage threshold	Regulator immediately turns off	Low	High	Auto-restart under control of soft-start when above BIAS and BOOT UVLO thresholds

**Control Loop**

To a first order, the small-signal loop can be modeled as shown in figure 3. The control loop can be broken into two sections: power stage and error amplifier.

**Power Stage**

The power stage includes the output filter capacitor ( $C_{OUT}$ ), the equivalent load ( $R_{LOAD}$ ), and: the inner current loop, PWM modulator, and power inductor, which together are modeled as a transconductance amplifier with a gain of 1.3 A/V. The signal  $V_c$ , supplied to the power stage, is effectively the load current demand signal. This signal effectively controls the valley current through the inductor; the higher the load the larger the  $V_c$  signal. To simplify matters, we will assume this signal controls the average current through the inductor as opposed to the valley current.

The effective DC gain of the power stage, without the output capacitor and load resistor, is 1.3 A/V, where the signal  $V_c$  is limited to the range 0.36 to 2.75 V. The DC current is converted into  $V_{OUT}$  as the current flows into the load resistor. The overall DC gain of the power stage is given as  $V_{OUT}/V_c$  (see figure 4). At full load, the  $V_c$  signal would be  $2/1.3 = 1.54$  V.

From a small-signal point of view, the power inductor behaves like a current source; the inductor can be ignored as far as the bandwidth of the loop is concerned. The output capacitor integrates the ripple current through the inductor, effectively forming a single pole with the output load.

The power stage pole can be found:

$$f_{p(PS)} = \frac{1}{2 \times \pi \times C_{OUT} \times R_{LOAD}} \quad (13)$$

It can be seen that as the load changes, the position of the power pole changes in the frequency domain. This may seem like an issue in terms of where to optimize the loop, however, the change in load also changes the gain in the power stage, thus compensating for this effect. Figure 4 illustrates how the loop response of the power stage changes with a varying load. The position of  $f_{p1}$  and  $G1$  is one solution,  $f_{p2}$  and  $G2$  is another solution, and so forth.

As the value of  $R_{LOAD}$  increases (reducing load), the power pole moves down in frequency and the DC gain increases. Generally speaking this is not a problem, because even if the pole approaches the low frequency pole produced by the error amplifier, there is still plenty of gain in the system. In this case, while the phase margin may be greatly reduced, even to a value approaching  $0^\circ$ , because there is sufficient DC gain in the loop it can be shown from Nyquist theory that the system is conditionally stable. The phase margin must be considered only at the 0 dB crossover frequency.

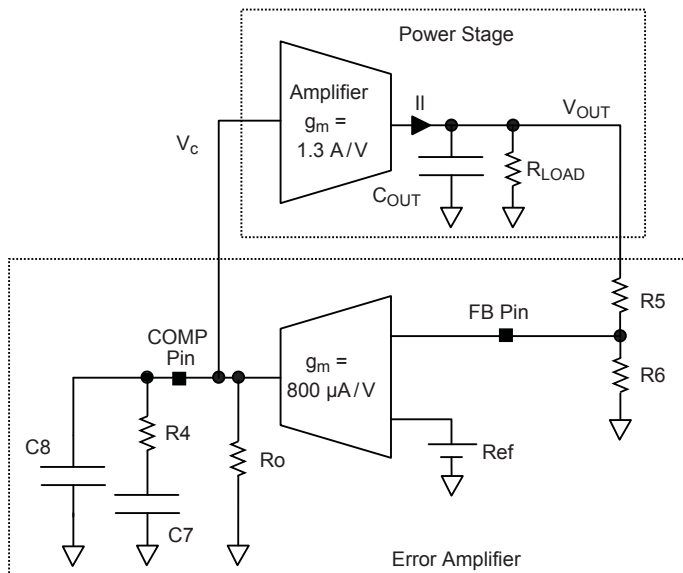

Figure 3. 1<sup>st</sup> order model of the small-signal control loop (see Typical Applications section circuit diagrams for component references)

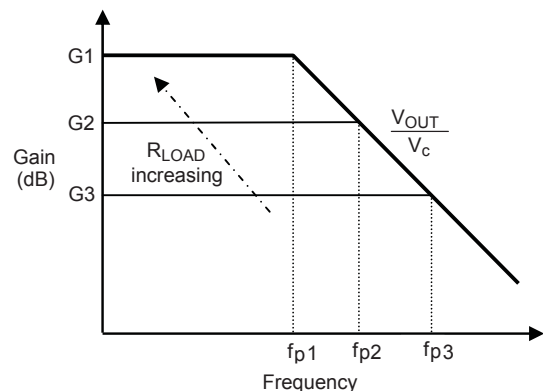

Figure 4. Power stage DC gain characteristic

It is recommended that X5R/ X7R ceramic capacitors be used, however, large-value capacitors such as electrolytic types can be used. Care should be taken when selecting the value of an electrolytic capacitor. As this capacitance is increased, the power pole is pushed to such a low frequency that the gain can fall off sufficiently to cause a loop instability.

If using an electrolytic capacitor, consideration should also be given to the equivalent series resistance (ESR) value, because this introduces a zero with the capacitance itself. It is important to use a low-ESR type capacitor. It should be noted that capacitor manufacturers usually quote an ESR which is a maximum at a particular frequency (such as 100 kHz) and temperature (20°C). The ESR does vary with frequency and temperature, plus there are tolerance effects as well. If the zero produced by the ESR of the output capacitor features in the control loop, it is strongly recommended that a large tolerance be allowed. If necessary, the high frequency pole in the error amplifier can be used to negate the effects of this pole (see the Error Amplifier section).

### Error Amplifier

The error amplifier is a transconductance amplifier. The DC gain of the amplifier is 61dB (1122) and, with a  $g_m$  value of 800  $\mu\text{A}/\text{V}$ , the effective output impedance of the amplifier can be modeled as:

$$R_O = \frac{1122}{800 \times 10^{-6}} = 1.4 \text{ M}\Omega \quad (14)$$

The transconductance amplifier has a high DC gain to ensure good regulation. The gain is rolled off with a single pole positioned at a low frequency. A zero is positioned at higher frequencies to cancel the effects of the main power stage pole. A second pole can be introduced which should have minimal effect on the loop response, but is useful for reducing the effects of switching noise.

The low frequency pole occurs at:

$$f_{p1(\text{EA})} = \frac{1}{2 \times \pi \times R_O \times C_7} \quad (15)$$

The zero occurs at:

$$f_{z(\text{EA})} = \frac{1}{2 \times \pi \times R_4 \times C_7} \quad (16)$$

The high frequency pole occurs at:

$$f_{p2(\text{EA})} = \frac{1}{2 \times \pi \times R_4 \times C_8} \quad (17)$$

The potential divider formed by R5 and R6 in figure 3 effectively introduces a DC offset to the loop. This can be found from:  $V_{\text{FB}} / V_{\text{OUT}}$ .

### Control Loop Design Approach

There are many different approaches to designing the feedback loop. The optimum solution is to select a target phase margin and bandwidth for optimum transient response. This typically requires either simulation software or detailed Bode plot analysis to generate a solution.

The particular approach described here derives a solution through a series of basic calculations. This approach aims for a simple  $-20$  dB/decade roll off, from the low frequency error amplifier pole ( $f_{p1(\text{EA})}$ ) to the 0 dB crossover point ( $f_{\text{cross}}$ ). The 0 dB crossover point is aimed at a thirteenth of the switching frequency ( $f_{\text{SW}}$ ). This factor is chosen as a compromise between good bandwidth and minimizing the phase lag introduced by the second power pole, which occurs between  $1/3$  and  $1/6$  of the switching frequency. In theory, this should introduce a phase margin of  $90^\circ$ , however, in practice it will be slightly less than this, perhaps by about  $5^\circ$ , due to the effects of the second power pole.

It is recommended that the error amplifier high frequency pole should be positioned one octave below the switching frequency. This provides some attenuation of the switching ripple whilst having minimum impact on the closed loop response.

To achieve a  $-20$  dB/decade roll off, the error amplifier zero is positioned to coincide with the power pole at maximum load.

Figure 5 illustrates the power stage gain, the error amplifier gain, and then the combined overall loop response (power stage and error amplifier).

**Design Example**

Assuming: output voltage ( $V_{OUT}$ ) = 1.5 V, maximum load ( $I_{OUT}$ ) = 2 A, switching frequency ( $f_{SW}$ ) = 700 kHz, and output capacitance ( $C_{OUT}$ ) = 20  $\mu$ F. Analyze the response at full load.

1. Crossover frequency:

$$f_{cross} = \frac{700 \times 10^3}{13} = 53.8 \text{ kHz} \quad (18)$$

2. Overall DC gain (refer to figure 5):

$$\text{DC gain (PS)} = 20 \text{ Log}_{10} \left( \frac{V_{OUT}}{V_c} \right) \quad (19)$$

$$\text{DC gain (EA)} = 61 \text{ dB} + 20 \text{ Log}_{10} \left( \frac{V_{FB}}{V_{OUT}} \right) \quad (20)$$

$$\text{DC gain (All)} = \text{DC gain (PS)} + \text{DC gain (EA)} \quad (21)$$

$$= 20 \text{ Log}_{10} \left( \frac{V_{OUT}}{V_c} \right) + 61 \text{ dB} + 20 \text{ Log}_{10} \left( \frac{V_{FB}}{V_{OUT}} \right)$$

$$= 20 \text{ Log}_{10} \left( \frac{1.5}{1.54} \right) + 61 \text{ dB} + 20 \text{ Log}_{10} \left( \frac{0.6}{1.5} \right)$$

$$= 52.8 \text{ dB}$$

Note: With a power stage gain of 1.3 A/V and a load of 2A, the corresponding  $V_c = 2/1.3 = 1.54$  V.

3. With a 53.8 kHz crossover and a 20 dB/decade increase in gain, at what frequency does the gain reach 52.8 dB? The  $-20$  dB/decade roll off can be described as a single pole with this transfer function for magnitude (G):

$$G = \frac{1}{2 \times \pi \times f \times RC} \quad (22)$$

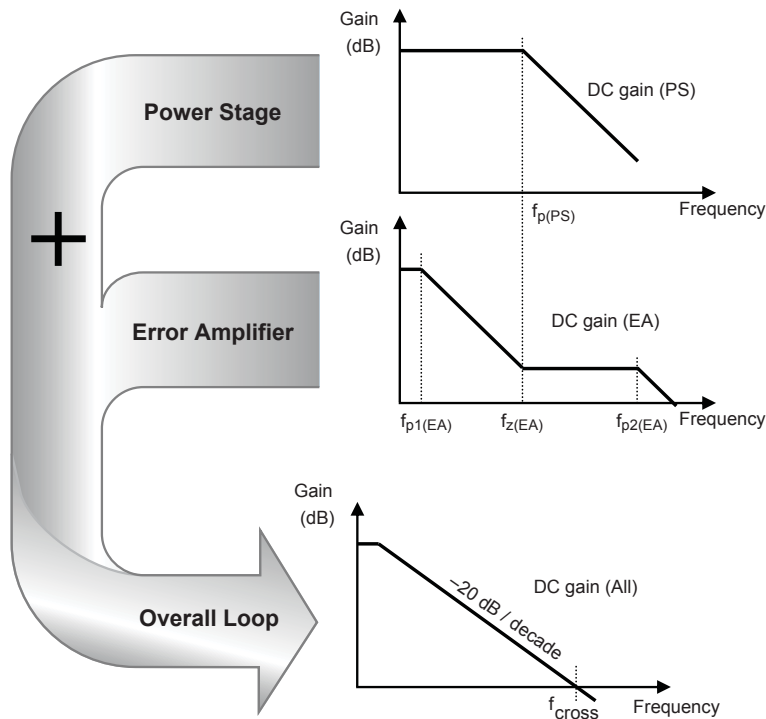

Figure 5. Power stage, error amplifier, and combined overall control loop response



3a. We know that at 53.8 kHz the gain is 0 dB (1). Therefore the constant RC can be worked out:

$$RC = \frac{1}{2 \times \pi \times 53.8 \times 10^3 \times 1} \quad (23)$$

$$= 2.96 \times 10^{-6}$$

3b. A magnitude of 52.8 dB = 436.5. The frequency at which a gain of 436.5 is reached is:

$$f = \frac{1}{2 \times \pi \times 2.96 \times 10^{-6} \times 436.5} \quad (24)$$

$$= 123 \text{ Hz}$$

So the overall loop response objective is shown in figure 6.

4. Select the RC components.

4a. The error amplifier pole ( $f_{p1(EA)}$ ) occurs at 123 Hz. Therefore, C7 can be found:

$$C_7 = \frac{1}{2 \times \pi \times R_O \times f_{p1(EA)}} \quad (25)$$

$$= \frac{1}{2 \times \pi \times 1.4 \times 10^6 \times 123}$$

$$= 1 \text{ nF}$$

4b. The power pole ( $f_{p(PS)}$ ) can be found, because the output capacitor ( $C_{OUT}$ ) and maximum load ( $R_{LOAD}$ ) are known:

$$f_{p(PS)} = \frac{1}{2 \times \pi \times R_{LOAD} \times C_{OUT}} \quad (26)$$

$$= \frac{1}{2 \times \pi \times 0.75 \times 20 \times 10^{-6}}$$

$$= 10\,610 \text{ Hz}$$

4c. The error amplifier zero ( $f_{z(EA)}$ ) also occurs at 10.610 kHz to cancel the effects of the power pole. Therefore, as C7 is known, R4 can be found:

$$R_4 = \frac{1}{2 \times \pi \times C_7 \times f_{p(PS)}} \quad (27)$$

$$= \frac{1}{2 \times \pi \times 1 \times 10^{-9} \times 10610}$$

$$= 15 \text{ k}\Omega$$

4d. The error amplifier high frequency pole ( $f_{p2(EA)}$ ) is set an octave below the switching frequency. Therefore, C8 can be found:

$$C_8 = \frac{1}{2 \times \pi \times R_4 \times (f_{SW}/2)} \quad (28)$$

$$= \frac{1}{2 \times \pi \times 15 \times 10^3 \times (700 \times 10^3 / 2)}$$

$$= 30 \text{ pF}$$

4e. Using the above compensation component selection technique, table 4 provides preferred component values for a given output voltage, 2 A output, at target switching frequencies of 500 kHz, 700 kHz, and 1 MHz.

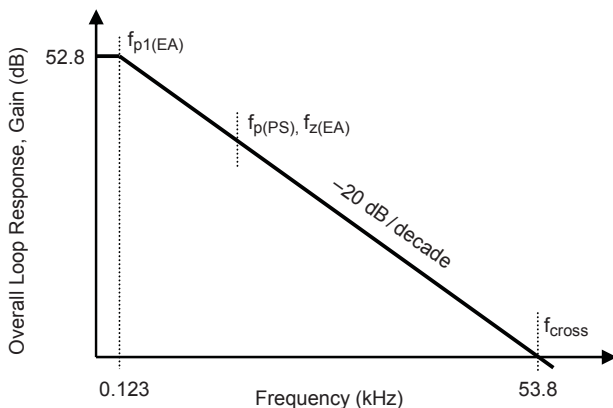

Figure 6. Design example objective: overall control loop response (power stage and error amplifier)

**Table 4. Recommended R4 and C7 Values**

Switching Frequency, $f_{SW}$								
500 kHz			700 kHz			1 MHz		
$V_{OUT}$ (V)	R4 (k $\Omega$ )	C7 (nF)	$V_{OUT}$ (V)	R4 (k $\Omega$ )	C7 (nF)	$V_{OUT}$ (V)	R4 (k $\Omega$ )	C7 (nF)
5.0	33	1.5	5.0	51	1.0	5.0	68	0.68
3.3	22	1.5	3.3	33	1.0	3.3	51	0.68
2.5	18	1.5	2.5	24	1.0	2.5	39	0.68
1.8	12	1.5	1.8	18	1.0	1.8	27	0.68
1.5	10	1.5	1.5	15	1.0	1.5	22	0.68
1.2	8.2	1.5	1.2	12	1.0	1.2	18	0.68
1.0	6.8	1.5	1.0	10	1.0	1.0	15	0.68
0.8	4.7	1.5	0.8	8.2	1.0	0.8	12	0.68
0.6	3.9	1.5	0.6	5.6	1.0	0.6	8.2	0.68

### Thermal Considerations

For a given set of conditions, the junction temperature of the A8670 can be estimated by carrying out a few calculations. This is important to ensure an adequate safety margin with respect to the maximum junction temperature (150°C) to enhance reliability. This exercise also helps to understand the overall efficiency of the regulator.

The general approach is to work out what thermal impedance ( $R_{\theta J-A}$ ) is required to maintain the junction temperature at a given level, for a particular power dissipation. It should be noted that this process is usually iterative to achieve the optimum solution.

The following steps can be used as a guideline for determining a suitable thermal solution. First, estimate the maximum ambient temperature ( $T_A$ ) of the application. Second, define the maximum junction temperature ( $T_J$ ). Note that the absolute maximum is 150°C. Third, determine the worst case power dissipation. This will typically occur at maximum load and minimum  $V_{IN}$ .

#### Design Example

Assuming: input voltage ( $V_{IN}$ ) = 12 V, output voltage ( $V_{OUT}$ ) = 1.2 V, maximum load ( $I_{OUT}$ ) = 2 A, switching frequency ( $f_{SW}$ ) = 500 kHz, target junction temperature ( $T_J$ ) ≤ 125°C, maximum ambient temperature ( $T_A$ ) = 105°C, and inductive resistance ( $DCR_L$ ) = 20 mΩ.

1. The main power loss contributors are calculated separately:

#### • Switch static losses

a. Estimate the  $R_{DS(on)}$  of the high-side switch at the maximum target junction temperature:

$$\begin{aligned} R_{DS(on)HS(T_J)} &= R_{DS(on)HS(25C)} \left( 1 + \frac{T_J - 25}{200} \right) \\ &= 200 \times 10^{-3} \left( 1 + \frac{125 - 25}{200} \right) \\ &= 0.3 \Omega \end{aligned} \quad (29)$$

where  $R_{DS(on)HS(25C)}$  is the  $R_{DS(on)HS}$  value that can be found from the Electrical Characteristics table in this datasheet.

b. Estimate the  $R_{DS(on)}$  of the low side switch at the given junction temperature:

$$\begin{aligned} R_{DS(on)LS(T_J)} &= R_{DS(on)LS(25C)} \left( 1 + \frac{T_J - 25}{200} \right) \\ &= 45 \times 10^{-3} \left( 1 + \frac{125 - 25}{200} \right) \\ &= 0.0675 \Omega \end{aligned} \quad (30)$$

where  $R_{DS(on)LS(25C)}$  is the  $R_{DS(on)LS}$  value that can be found from the Electrical Characteristics table in this datasheet.

c. Estimate the duty cycle (D) by applying equation 3 ( $t_{on}$ ):

$$\begin{aligned} D &= \frac{t_{on} \times f_{SW}}{1} \\ &= \left( \frac{V_{OUT} + (R_{DS(on)LS} + DCR_L) \times I_{OUT}}{V_{IN} + (R_{DS(on)LS} - R_{DS(on)HS}) \times I_{OUT}} \times \frac{1}{f_{SW}} \right) \times f_{SW} \\ &= \left( \frac{1.2 + (0.068 + 0.02) \times 2}{12 + (0.068 - 0.3) \times 2} \times \frac{1}{500 \times 10^3} \right) \times 500 \times 10^3 \\ &= 0.12 \end{aligned} \quad (31)$$

d. The high side static loss can be determined:

$$\begin{aligned} P_{staticHI} &= I_{OUT}^2 \times D \times R_{DS(on)HS(T_J)} \\ &= 2^2 \times 0.12 \times 0.3 \\ &= 0.144 \text{ W} \end{aligned} \quad (32)$$

e. The low side static loss can be determined:

$$\begin{aligned} P_{staticLO} &= I_{OUT}^2 \times (1 - D) \times R_{DS(on)LS(T_J)} \\ &= 2^2 \times (1 - 0.12) \times 0.068 \\ &= 0.239 \text{ W} \end{aligned} \quad (33)$$

• **Switching losses** The combined turn on and turn off losses for both switches are calculated as:

$$\begin{aligned} P_{switch} &= \frac{V_{IN}}{2} \times I_{OUT} \times 6 \times 10^{-9} \times f_{SW} \times 2 \\ &= \frac{12}{2} \times 2 \times 6 \times 10^{-9} \times 500 \times 10^3 \times 2 \\ &= 0.072 \text{ W} \end{aligned} \quad (34)$$

• **Recirculation diode losses** The recirculation diode losses (low-side switch) are calculated as:

$$\begin{aligned} P_{\text{recirc}} &= 0.8 \times I_{\text{OUT}} \times 6 \times 10^{-9} \times f_{\text{SW}} \\ &= 0.8 \times 2 \times 6 \times 10^{-9} \times 500 \times 10^3 \\ &= 0.005 \text{ W} \end{aligned} \quad (35)$$

• **Diode transit losses** The recirculation diode losses (low-side switch) are calculated as:

$$\begin{aligned} P_{\text{transit}} &= V_{\text{IN}} \times I_{\text{OUT}} \times 3 \times 10^{-9} \times f_{\text{SW}} \\ &= 12 \times 2 \times 3 \times 10^{-9} \times 500 \times 10^3 \\ &= 0.036 \text{ W} \end{aligned} \quad (36)$$

• **BIAS losses** The supply bias losses are calculated as:

$$\begin{aligned} P_{\text{bias}} &= V_{\text{IN}} \times 7.2 \times 10^{-3} \\ &= 0.086 \text{ W} \end{aligned} \quad (37)$$

2. The total losses in the A8670 can be estimated:

$$\begin{aligned} P_{\text{total}} &= P_{\text{staticHI}} + P_{\text{staticLO}} + P_{\text{switch}} + P_{\text{recirc}} + P_{\text{transit}} + P_{\text{bias}} \\ &= 0.144 + 0.239 + 0.072 + 0.005 + 0.036 + 0.086 \\ &= 0.582 \text{ W} \end{aligned} \quad (38)$$

3. The thermal impedance required for the solution can be found:

$$\begin{aligned} R_{\theta\text{JA}} &= \frac{T_{\text{J}} - T_{\text{A}}}{P_{\text{total}}} \\ &= \frac{125 - 105}{0.582} \\ &= 34 \text{ }^\circ\text{C/W} \end{aligned} \quad (39)$$

For this particular solution, a high thermal efficiency board is required to ensure the junction temperature is kept below 125°C. It is recommended to use a PCB with four layers. The A8670 should be mounted onto a thermal pad. A number of vias should connect the thermal pad to at least one of the internal layers and the bottom side of the PCB. Both of these layers should be a ground plane. See the Layout section for more information.

### Regulator Efficiency

The overall regulator efficiency can be determined by including the inductor loss. In the above thermal characteristics example, the inductor resistance,  $\text{DCR}_{\text{L}} = 20 \text{ m}\Omega$ . Therefore the inductor power loss can be found::

$$\begin{aligned} P_{\text{L}} &= \text{DCR}_{\text{L}} \times I_{\text{OUT}}^2 \\ &= 0.02 \times 2^2 \\ &= 0.08 \text{ W} \end{aligned} \quad (40)$$

The overall regulator efficiency can be found:

$$\begin{aligned} \eta &= \frac{V_{\text{OUT}} \times I_{\text{OUT}}}{(V_{\text{OUT}} \times I_{\text{OUT}}) + P_{\text{total}} + P_{\text{L}}} \\ &= \frac{1.2 \times 2}{(1.2 \times 2) + 0.582 + 0.08} \\ &= 78.4 \% \end{aligned} \quad (41)$$

### Layout

Although the power dissipation in the A8670 is very low, it is recommended that the thermal pad of the device is soldered to an appropriate pad on the printed circuit board to help minimize the junction temperature and enhance the efficiency. The PCB pad should in turn be connected to the ground plane via a number of thermal vias. As a suggestion, the following could be used: sixteen vias, arranged in 4 rows of 4, with diameter 0.25 mm and spaced (pitch) 0.6 mm apart. The PCB pad as well as acting as a thermal connection, also forms the star connection for the grounding system.

Figure 7 illustrates the key objectives in the grounding system. The filtering capacitors: C1, C3, C4, and C6 should be connected as close as possible to their respective pins. The ground connections for each of the capacitors should be returned directly to the star connection (PCB pad). Again, these connections should be as short as possible. Both the PGND and AGND connections should connect directly to the PCB pad to form the star connection.

The ground return connection for the feedback resistor should be Kelvin-connected directly back to the star ground. Note: To avoid voltage offset errors in the output voltage, the feedback resistor should not be connected to the filter capacitor or load grounds returns.

The support components (C5, C7, and C8) that are ground referenced should be connected together locally and then a common trace used to return directly to the star connection. Again, this ground should not pick-up any of the filter capacitors or load ground returns.

Due to the high impedance nature of the COMP node, it is important to ensure the compensation components are connected as close as possible. The feedback trace from R5 and R6 to the FB pin is also a high impedance input and should be as short as possible and be placed well away from noisy connections such as LX. It is recommended to keep any ground planes well away from the LX node to avoid any potential noise coupling effects.

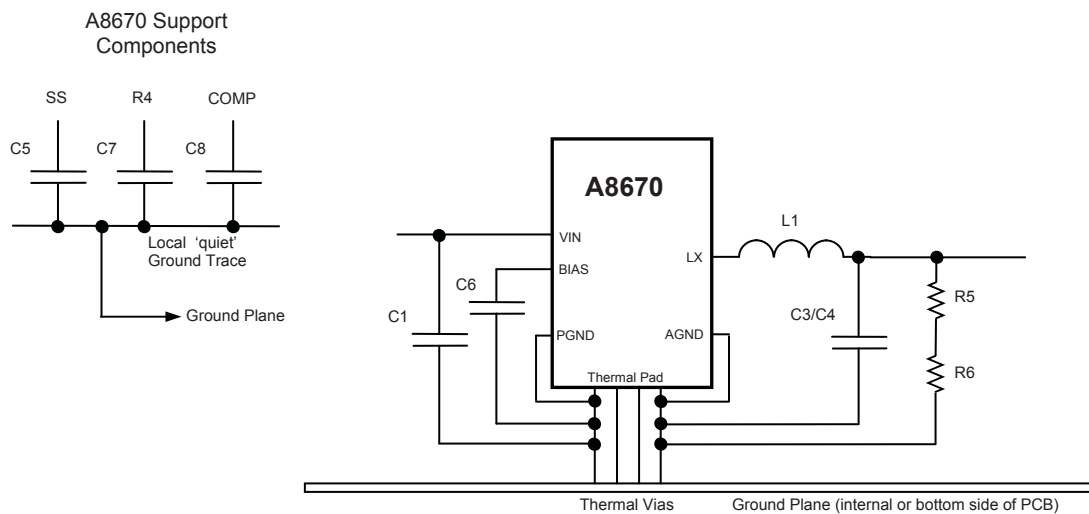
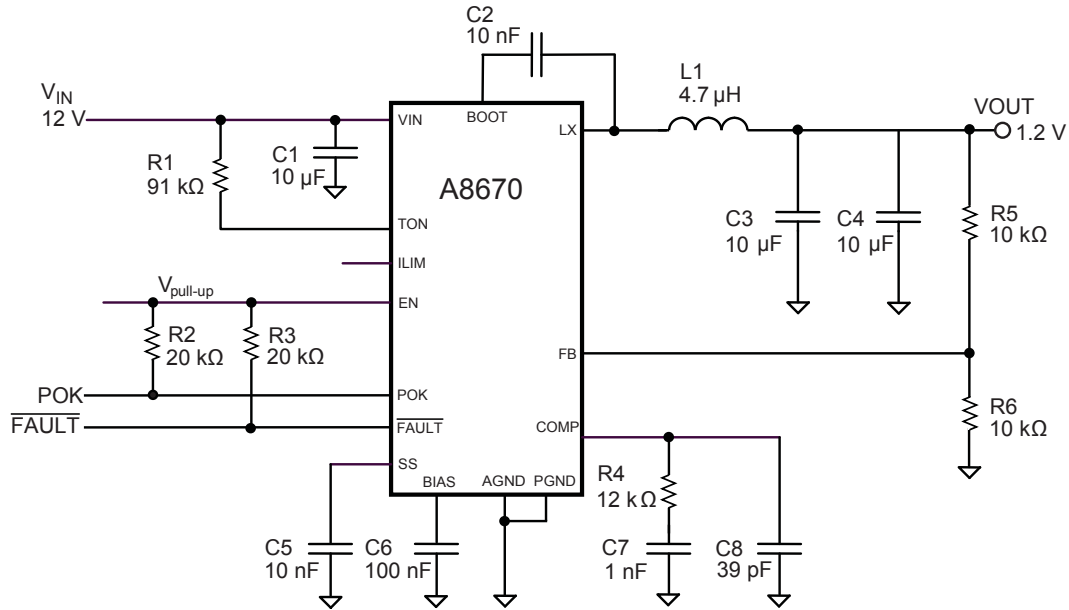

Figure 7. Layout considerations for mounting the A8760

### Typical Applications

#### Application circuit 1



Operating Characteristics:  $V_{IN} = 12\text{ V}$ ,  $V_{OUT} = 1.2\text{ V}$ ,  $f_{SW} = 500\text{ kHz}$

Inductor used: Taiyo Yuden NR8040 4.7  $\mu\text{H}$

Further improvements can be made to the efficiency of this circuit by:

- Adding a 1 A Schottky diode between the LX node and ground.
- Using an inductor with a lower DCR.

#### Measured efficiency for this circuit

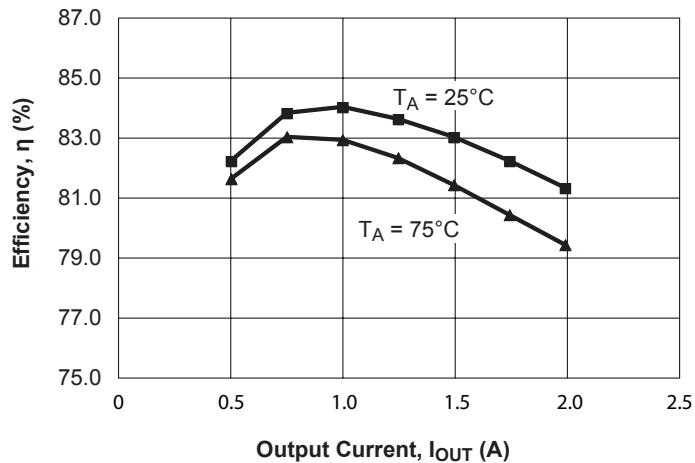

### Application circuit 2

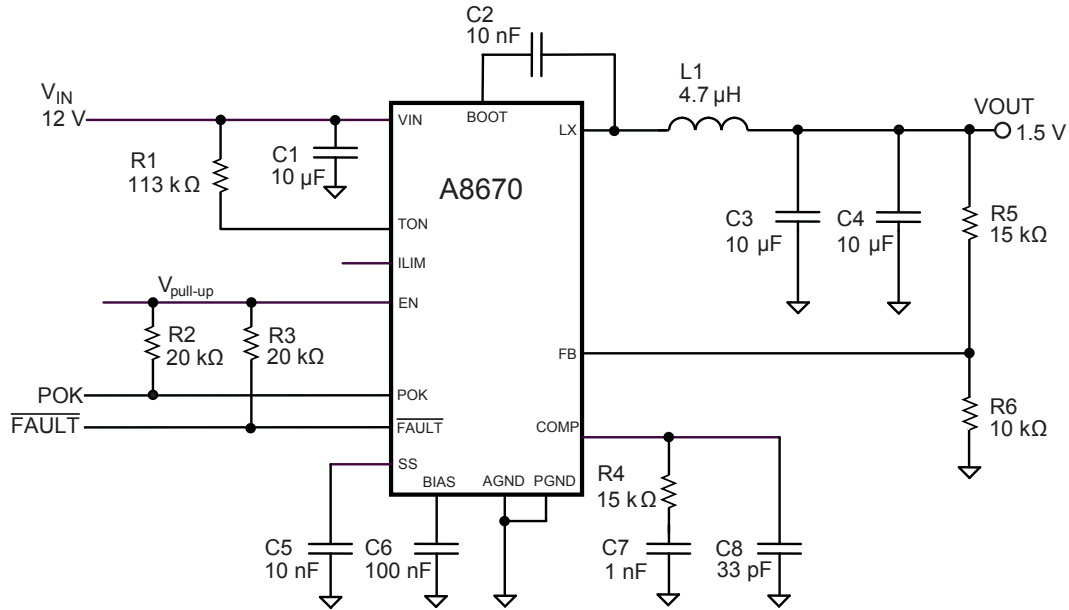

Operating Characteristics:  $V_{IN} = 12\text{ V}$ ,  $V_{OUT} = 1.5\text{ V}$ ,  $f_{SW} = 500\text{ kHz}$

Inductor used: Taiyo Yuden NR8040 4.7  $\mu\text{H}$

Further improvements can be made to the efficiency of this circuit by:

- Adding a 1 A Schottky diode between the LX node and ground.
- Using an inductor with a lower DCR.

### Measured efficiency for this circuit

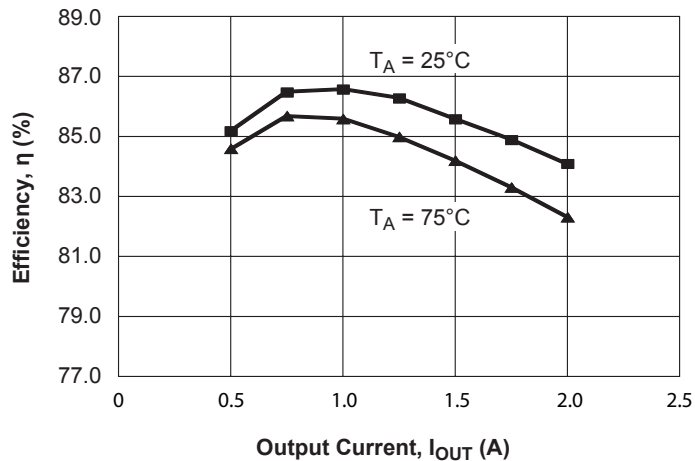

### Application circuit 3

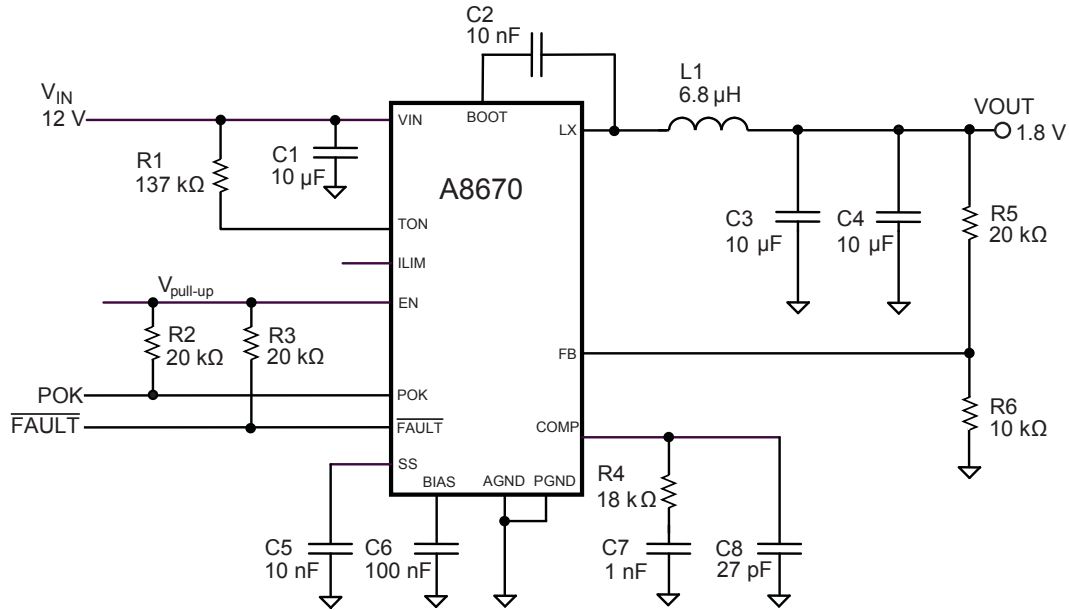

Operating Characteristics:  $V_{IN} = 12\text{ V}$ ,  $V_{OUT} = 1.8\text{ V}$ ,  $f_{SW} = 500\text{ kHz}$

Inductor used: Taiyo Yuden NR8040 6.8  $\mu\text{H}$

Further improvements can be made to the efficiency of this circuit by:

- Adding a 1 A Schottky diode between the LX node and ground.
- Using an inductor with a lower DCR.

### Measured efficiency for this circuit

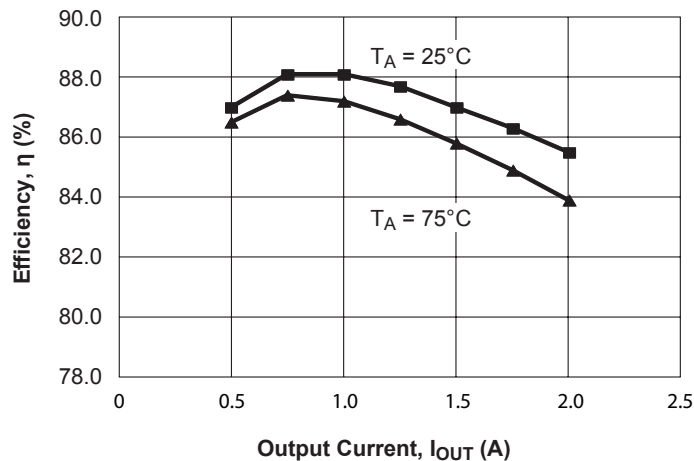

### Application circuit 4

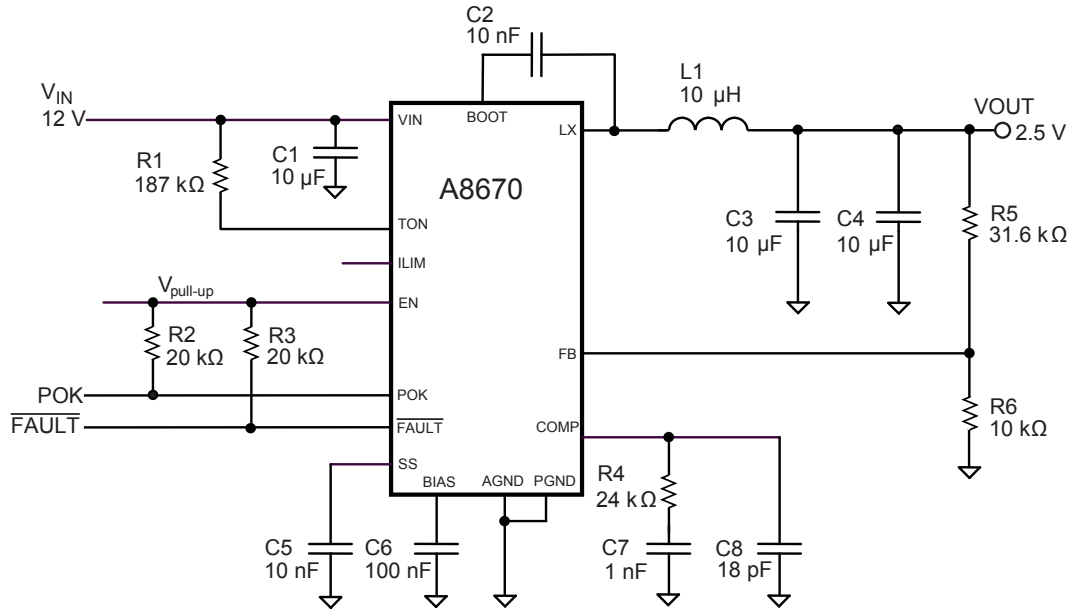

Operating Characteristics:  $V_{IN} = 12\text{ V}$ ,  $V_{OUT} = 2.5\text{ V}$ ,  $f_{SW} = 500\text{ kHz}$

Inductor used: Taiyo Yuden NR8040 10  $\mu\text{H}$

Further improvements can be made to the efficiency of this circuit by:

- Adding a 1 A Schottky diode between the LX node and ground.
- Using an inductor with a lower DCR.

### Measured efficiency for this circuit

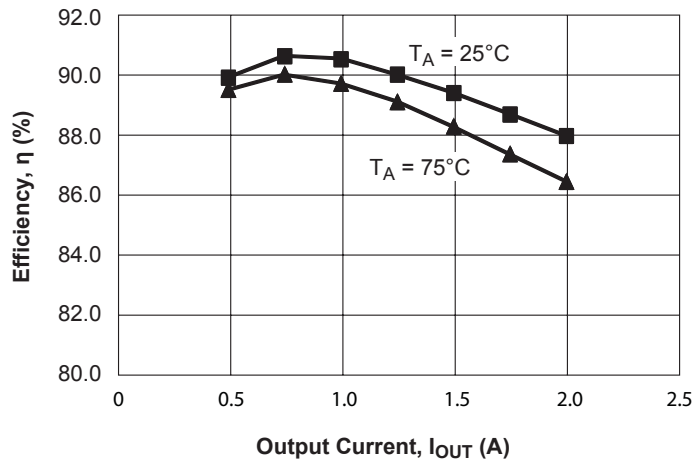



### Application circuit 5

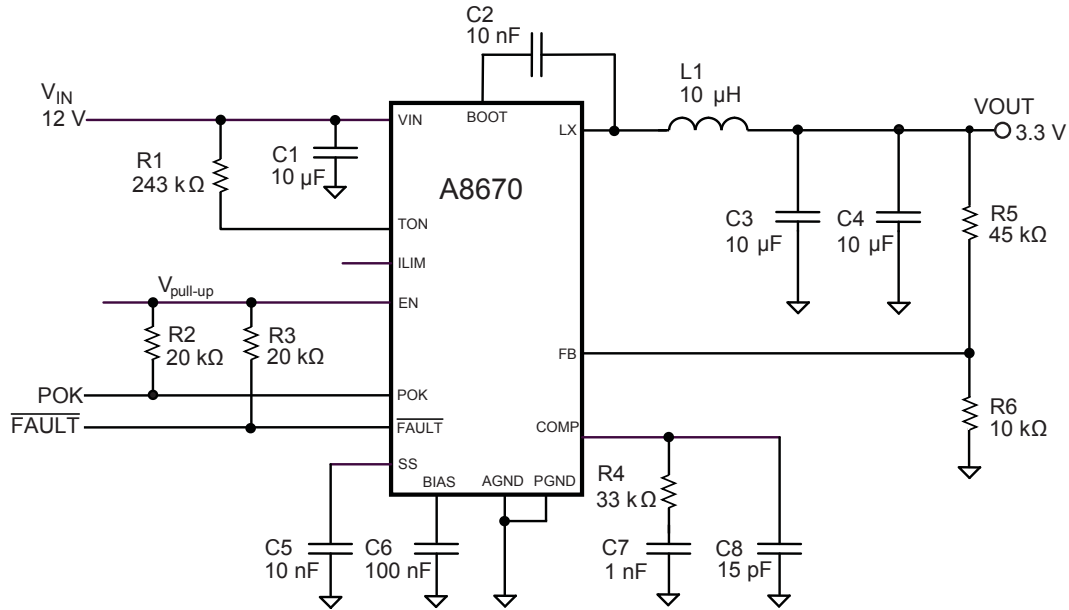

Operating Characteristics:  $V_{IN} = 12\text{ V}$ ,  $V_{OUT} = 3.3\text{ V}$ ,  $f_{SW} = 500\text{ kHz}$

Inductor used: Taiyo Yuden NR8040 10  $\mu\text{H}$

Further improvements can be made to the efficiency of this circuit by:

- Adding a 1 A Schottky diode between the LX node and ground.
- Using an inductor with a lower DCR.

### Measured efficiency for this circuit

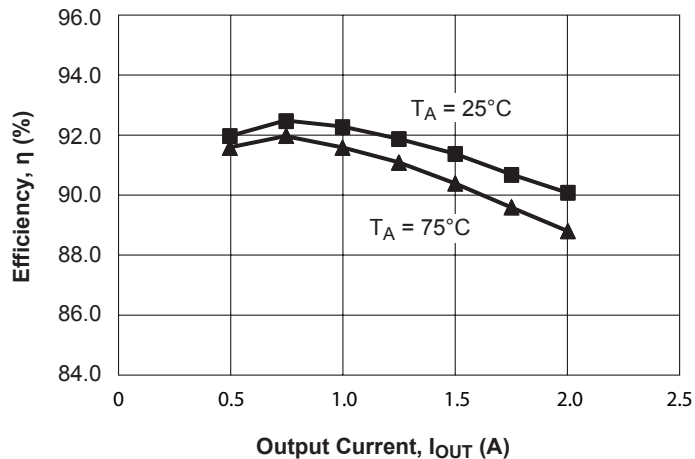

### Application circuit 6

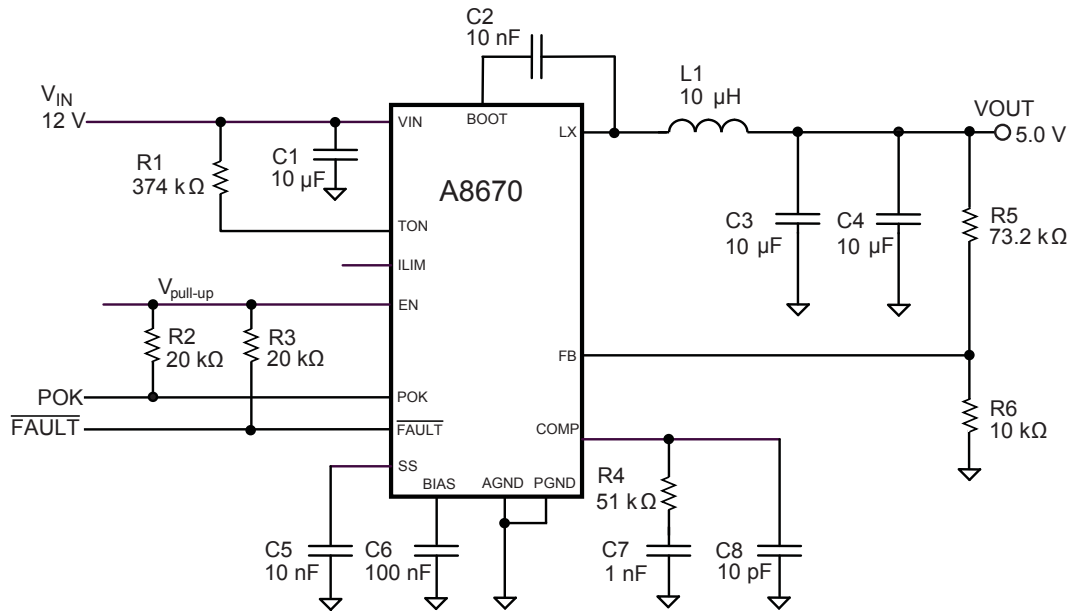

Operating Characteristics:  $V_{IN} = 12\text{ V}$ ,  $V_{OUT} = 5.0\text{ V}$ ,  $f_{SW} = 500\text{ kHz}$

Inductor used: Taiyo Yuden NR8040 10  $\mu\text{H}$

Further improvements can be made to the efficiency of this circuit by:

- Adding a 1 A Schottky diode between the LX node and ground.
- Using an inductor with a lower DCR.

### Measured efficiency for this circuit

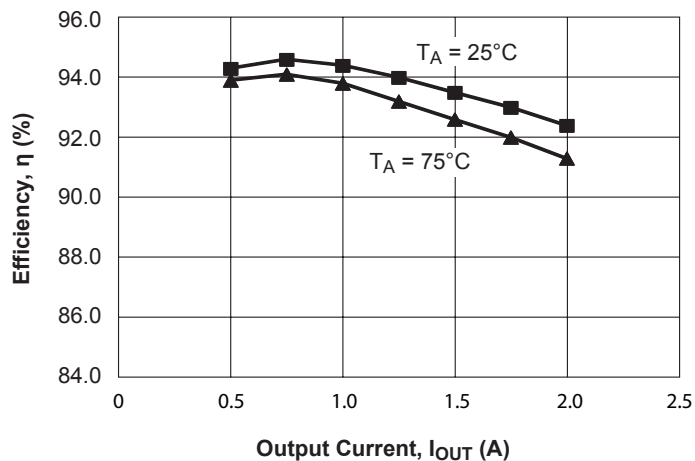

**Package ES, 20-Contact QFN**

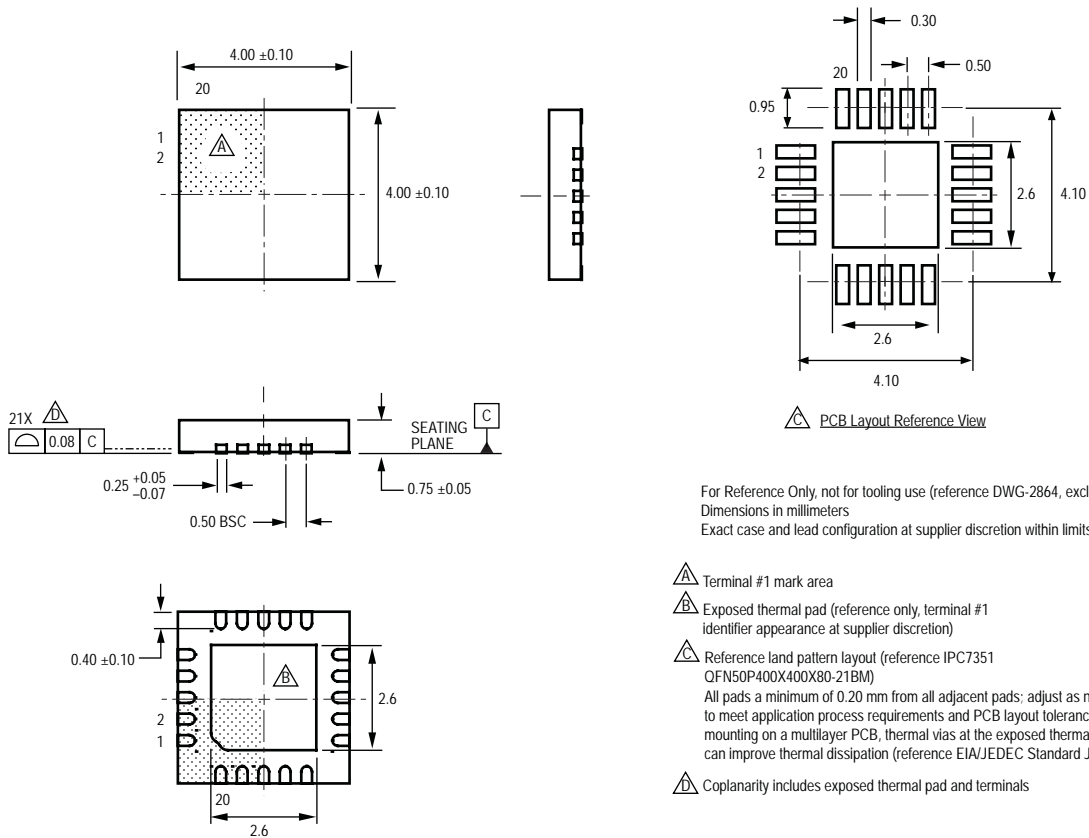

For Reference Only, not for tooling use (reference DWG-2864, excluding pad)  
Dimensions in millimeters  
Exact case and lead configuration at supplier discretion within limits shown

- △ Terminal #1 mark area
- △ Exposed thermal pad (reference only, terminal #1 identifier appearance at supplier discretion)
- △ Reference land pattern layout (reference IPC7351 QFN50P400X400X80-21BM)  
All pads a minimum of 0.20 mm from all adjacent pads; adjust as necessary to meet application process requirements and PCB layout tolerances; when mounting on a multilayer PCB, thermal vias at the exposed thermal pad land can improve thermal dissipation (reference EIA/JEDEC Standard JESD51-5)
- △ Coplanarity includes exposed thermal pad and terminals

**Revision History**

Revision	Revision Date	Description of Revision
Rev. 2	March 29, 2012	Update $t_{on(max)}$ and various minor changes

Copyright ©2011-2013, Allegro MicroSystems, LLC

Allegro MicroSystems, LLC reserves the right to make, from time to time, such departures from the detail specifications as may be required to permit improvements in the performance, reliability, or manufacturability of its products. Before placing an order, the user is cautioned to verify that the information being relied upon is current.

Allegro's products are not to be used in any devices or systems, including but not limited to life support devices or systems, in which a failure of Allegro's product can reasonably be expected to cause bodily harm.

The information included herein is believed to be accurate and reliable. However, Allegro MicroSystems, LLC assumes no responsibility for its use; nor for any infringement of patents or other rights of third parties which may result from its use.

For the latest version of this document, visit our website:

[www.allegromicro.com](http://www.allegromicro.com)

