

2. GENERAL SCOPE

This specification describes the performance characteristic of a 800W AC-DC switching redundant power supply. The power supply shall be able to operate as a single supply, or in a 1+1 parallel hot-plug able operation with active load sharing in a 1+1 redundant configuration.

2.1 Mechanical Overview

The physical size of the power supply enclosure is intended to accommodate the power range of up to 800W. The physical size is 83.8mm x 76mm x 250mm (height x width x length).

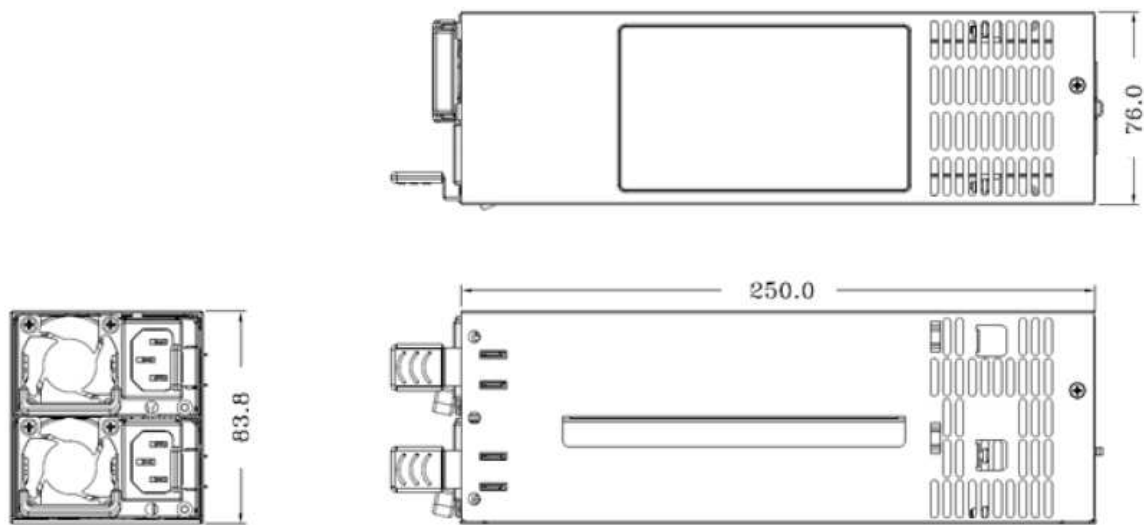

Figure 1 – Power Supply Dimension

2.2 LED Marking and Identification

The power supply shall have two LED for indication of the power supply status.

Table 1 – LED Status Information

Power supply condition	Power supply LED
Output ON and OK	Solid Green
No AC power to all power supplies	OFF
AC present/only standby output on	1Hz Blink Green
AC cord unplugged or AC power lost; with a second power supply in parallel still with AC input power.	Solid Amber
Power supply warning events where the power supply continues to operate; high temp, high power, high current, slow fan.	1Hz Blink Amber
Power supply critical event causing a shutdown failure; OCP, OVP, UVP	1Hz Blink Green
Power supply critical event causing a shutdown failure; OTP, Fan Fail	Solid Amber
Power supply FW update mode of Module	2Hz Blink Green
Power supply FW update mode of Housing	1Hz Blink Green

2.3 Environmental Requirements

The power supply shall operate within all specified limits over specified conditions in 2.3.

The defined operation condition include temperature, humidity, altitude, shock and vibration.

2.3.1 Temperature and Humidity Requirements

The power supply shall operate within all specified limits over T_{op} temperature range and specified humidity Range. All airflow shall pass through the power supply and not over the exterior surfaces of the power supply.

The power supply shall withstand thermal storage specified in T_{non-OP} without any damage.

Table 2 – Temperature Requirements

Item	Description	MIN	MAX	Unit
T_{OP}	Operating temperature range.	0	50	°C
T_{non-OP}	Non-Operating temperature range.	-40	70	°C
H_{OP}	Operating humidity range, non condensing		90	%
H_{non-OP}	Non-Operating humidity range, non condensing		95	%

2.3.2 Altitude Requirements

The power supply shall operate within all specified limits over A_{op} Altitude range. The change pressure condition shall not harm the power supply and the operation within specified regulations shall be assured.

The power supply shall withstand Altitude storage specified in A_{non-OP} without any damage.

Table 3 – Altitude Requirements

Item	Description	MIN	MAX	Unit
A_{OP}	Operating Altitude range.	0	5000	m
A_{non-OP}	Non-Operating Altitude range.	0	15000	m

3. ELECTRICAL PERFORMANCE

3.1 AC power Input Specification

3.1.1 AC Inlet connector

The power supply shall incorporate an AC input connector complying to IEC 320 C-14 power inlet connector specification. This inlet shall be rated for operation at 10A/250VAC.

3.1.2 Input voltage and frequency specification

The power supply shall operate within all specified limits over the following input range. Harmonic distortions of up to 10% of the rated line voltage must not cause the power supply to go out of specified limits.

The power supply shall power off if the AC input is below VAC_{low_limit} and shall start (auto recover) if $VAC_{recover}$ is reached. Input of VAC below $VAC_{recover}$ shall not cause any damage to the power supply, including the input fuse.

The power supply shall supply the full output power in the voltage range of 90VAC to 264VAC.

Table 4 – Rated output power for each input voltage range

Parameter	Minimum input	Rated Input	Maximum input
115 VAC	90V _{rms}	100-127V _{rms}	140V _{rms}
230 VAC	180V _{rms}	200-240V _{rms}	264V _{rms}
Frequency	47Hz	50/60Hz	63Hz

3.1.3 HVDC Input voltage

The power supply supports High Voltage Direct Current (HVDC) input. Allowed HVDC input range as shown in below table. The power supply shall operate within all specified limits, when HVDC input meet requirements defined in this chapter.

Table 5 – HVDC input voltage range

Parameter	Minimum input	Rated Input	Maximum input
HVDC(240)	180V	240V	310V

3.1.4 Input current

The maximum input current defines the maximum possible input current to ensure the proper function of the power supply to meet all defined specifications.

Table 6 – Maximum input current

Input voltage	Input current	Max power
90VAC	11A	800W
100-127VAC	10A	800W
180VAC	5.5A	800W
200-240VAC	5A	800W
264VAC	3.5A	800W
240VDC	4A	800W

3.1.5 AC Line Fuse

The power supply shall incorporate one input fuse on the line side for input over-current protection to prevent damage to the power supply and meet product safety requirements. AC inrush current shall not cause the AC line fuse to blow under any conditions. All protection circuits in the power supply shall not cause the AC fuse to blow unless a component in the power supply has failed. This includes DC output load short conditions.

3.1.6 AC line inrush

AC line inrush current shall not exceed 55A peak, for up to one-quarter of the AC cycle, after which, the input current should be no more than the specified maximum input current. The peak inrush current shall be less than the ratings of its critical components (including input fuse, bulk rectifiers, and surge limiting device).

The power supply must meet the inrush requirements for any rated AC voltage, during turn on at any phase of AC voltage, during a single cycle AC dropout condition as well as upon recovery after AC dropout of any duration, and over the specified temperature range (Top).

3.1.7 Input Power Factor Correction

The input Power Factor shall be greater than 0.98/115Vac and 0.95/230Vac (show the below Table 7).

Table 7 – module Power Factor Correction

Input voltage	20% loading	50% loading	100% loading
115VAC/60Hz	>0.8	>0.95	0.98
230VAC/50Hz	>0.8	>0.95	0.95

3.1.8 AC line dropout

An AC line dropout is a transient condition defined as the AC input to the power supply drops to 0 VAC at any phase of the AC line for any length of time. During an AC dropout the power supply must meet dynamic voltage regulations requirements. An AC line dropout of any duration shall not cause dripping of the control signals and protection circuits. If the AC dropout lasts longer than the holdup time, the power supply should recover when VAC meets $VAC_{recover}$ and meet all turn on requirements.

A Input dropout of any length shall not cause any damage to the power supply.

Table 8 – Hold-up time until Power output goes out of regulations

Loading	Main output	Standby output
100%	12mS	70mS

3.1.9 Efficiency

The redundant power supply module efficiency should meet at least Climate Saver 3 / 80Plus Platinum rating, specified in below table. The efficiency should be measured at 230VAC and with external fan power according to Climate Saver / 80Plus efficiency measurement specifications (CSCI-09-10)

Table 9 – module efficiency requirements

Efficiency Std.	20% load (12V is 13A,12vsb is 0.42A)	50% load (12V is 32.5A,12vsb is 1.05A)	100% load (12V is 65A,12vsb is 2.1A)
Platinum	90%	94%	91%

3.1.10 Susceptibility Requirements

The power supply shall meet the following electrical immunity requirements when connected to a cage with an external EMI filter, which meets the criteria defined in the SSI document EPS Power Supply Specification.

Table 10 – Performance criteria

Level	Description
A	The apparatus shall continue to operate as intended. No degradation of performance.
B	The apparatus shall continue to operate as intended. No degradation of performance beyond spec. limits.
C	Temporary loss of function is allowed provided the function is self-recoverable or can be restored by the operation of the controls.

3.1.10.1 Electrical Discharge Susceptibility

The power supply shall comply with the limits defined in EN 55024:1998 using the IEC 61000-4-2:1995 test standard and performance criteria B defined in Annex B of CISPR 24.

3.1.10.2 Fast Transient/Burst

The power supply shall comply with the limits defined in EN55024:1998 using the IEC 61000-4-4:1995 test standard and performance criteria B define in Annex B of CISPR 24.

3.1.10.3 Radiated Immunity

The power supply shall comply with the limits defined in EN55024:1998 using the IEC61000-4-3:1995 test standard and performance criteria A defined in Annex B of CISPR 24.

3.1.10.4 Surge Immunity

The power supply shall be tested with the system for immunity to AC Ringwave and AC Unidirectional wave, both up to 2kV(Differential mode 2K,Common mode 1K), per EN55024:1998, EN 61000-4-5:1995 and ANSI C62.45:1992.

The pass criteria include: No unsafe operation is allowed under any condition; all power supply output voltage levels to stay within proper spec levels; No change in operating state or loss of data during and after the test profile; No component damage under any condition.

The power supply shall comply with the limits defined in EN55024:1998 using the IEC 61000-4-5:1995 test standard and performance criteria B defined in Annex B f CISPR 24.

3.1.10.5 AC Line Transient Specification

AC line transient conditions shall be defined as “sag” and “surge” conditions.

“Sag” conditions are also commonly referred to as “brownout”, these conditions will be defined as the AC line voltage dropping below nominal voltage conditions.

“Surge” will be defined to refer to conditions when the AC line voltage rises above nominal voltage.

The power supply shall meet the requirements under the following AC line sag and surge conditions.

Table 11 – AC Line SAG transient performance.

AC Line Sag (10sec interval between each sagging)				
Duration	Sag	Operating AC voltage	Line frequency	Performance criteria
0 to 1/2 AC cycle	95%	Nominal AC voltage	50/60Hz	No loss of function or performance
>1 AC cycles	>30%	Nominal AC voltage	50/60Hz	Loss of function acceptable, self recoverable

Table 12 – AC Line SURGE transient performance.

AC Line Surge				
Duration	Surge	Operating ac voltage	Line frequency	Performance criteria
Continuous	10%	Nominal AC voltage	50/60Hz	No loss of function or performance
0 to 1/2 AC cycle	30%	mid-point of nominal AC voltage	50/60Hz	No loss of function or performance

3.1.10.6 AC line fast transient (EFT) specification

The power supply shall meet the EN61000-4-5 directive and any additional requirements in IEC1000-4-5:1995 and the level 3 requirements for surge-withstand capability, with the following conditions and exceptions:

- These input transients must not cause any out-of-regulation conditions, such as overshoot and undershoot, nor must it cause any nuisance trips of any of the power supply protection circuits.
- The surge-withstand test must not produce damage to the power supply.
- The supply must meet surge-withstand test conditions under maximum and minimum DC-output load conditions.

3.1.11 Power Recovery

The power supply shall recover automatically (auto recover) after an AC power failure. AC power failure is defined to be any loss of AC power that exceeds the dropout criteria.

3.1.12 Voltage Brown Out

The power supply shall comply with the limits defined in EN55024:1998 using the IEC 61000-4-11:1995 test standard and performance criteria C defined in Annex B of CISPR 24.

In addition the power supply shall meet the following requirements:

A continuous input voltage below the nominal input range shall not damage the power supply or cause overstress to any

power supply component. The power supply must be able to return to normal power up state after a brownout (Sag) condition. During brownout test from 120VAC to 0VAC @ 800W with 3mins ramp, input current shall never exceed fuse and shall not blow the fuse.

3.1.13 AC Line Leakage Current

The maximum leakage current to ground for each power supply shall be 1.0 mA when tested at 264Vac/60Hz.

3.2 DC output voltages

3.2.1 Grounding

The output ground of the pins of the power supply provides the output power return path. The ground output at the PCB card edge shall be connected to the safety ground (power supply enclosure). This grounding should be well designed to ensure passing the max allowed Common Mode Noise levels.

The power supply shall be provided with a reliable protective earth ground. All secondary circuits shall be connected to protective earth ground. Resistance of the ground returns to chassis shall not exceed 100 mΩ (Test Conditions 40A for 120sec). This path may be used to carry DC-current.

3.2.2 Output rating

The following table defines the power and current rating of the 800W power supply. The combined output power of all outputs shall not exceed the rated output power. The power supply must meet both static and dynamic voltage regulation requirements.

Table 13 – Output Power and Current Ratings

Output	Minimum Current(A)	Maximum Current(A)	Output Power(W)		
+12V	0.5	65	780W	780W	800W
+5V	0	25	160W		
+3.3V	0	25			
-12V	0	0.3	3.6W		
+5Vsb	0	4.5	22.5W		

3.2.3 Auxiliary Output (Standby)

The 12Vsb output shall be present when an AC input greater than V_{recover} is applied.

3.2.4 No load operation

The power supply shall meet all requirements except for the transient loading requirements when operated at no load on all outputs.

3.2.5 Voltage Regulation

The power supply shall meet the Voltage regulation under all operating conditions (AC line, transient loading, output loading). These limits include the peak-peak ripple/noise. The regulation of Table 14 shall be measured at the output connector of the power supply, subject to the dynamic loading conditions in paragraph 3.2.7.

Table 14 – Output Voltage regulation

Output	Minimum	Nominal	Maximum	Unit
+12V	11.4	12.0	12.6	Vdc
+5V	4.75	5.0	5.25	Vdc
+3.3V	3.135	3.3	3.465	Vdc
-12V	-11.40	-12.0	-12.6	Vdc
+5Vsb	4.75	5.0	5.25	Vdc

3.2.6 Ripple and Noise Regulation

Ripple and Noise is defined in table 15. Ripple and Noise shall be measured over a Bandwidth of 0Hz to 20MHz at the power supply output connector. A 0.1 μ F ceramic capacitor and 10 μ F of tantalum capacitor shall be placed at each point of measurement. The measurement points shall be as close as possible to the point of load.

The ripple and noise specification shall be met over all load ranges and AC line voltages with 1+1 power supplies in parallel operation.

Table 15– Ripple and Noise Regulation

Output	Maximum	Unit
+12V	120	mV
+5V	50	mV
+3.3V	50	mV
-12V	120	mV
+5Vsb	50	mV

3.2.7 Dynamic loading

The power supply shall operate within specified limits and meet regulation requirements for step loading and capacitive loading specified below.

The load transient repetition rate shall be tested between 50Hz to 5kHz at duty cycles ranging . The load transient repetition rate is only a test specification. The Δ step load may occur anywhere within the MIN load and the MAX load.

This shall be tested with no additional bulk capacitance added to the load.

Table 16 – Transient Load Requirements

Output	Δ Step size	Slew Rate	Capacitive Load
+3.3V	30% OF MAX.	0.25A/ μ s	2200 μ F
+5V	30% OF MAX.	0.25A/ μ s	2200 μ F
+12V	60% OF MAX.	0.25A/ μ s	4700 μ F
+5Vsb	25% OF MAX.	0.25A/ μ s	100 μ F

Note: For dynamic conditions +12V min. loading is 1A.

3.2.8 Capacitive load

The power supply shall operate within specifications over the capacitive loading ranges defined below in table 17.

Table 17 – Capacitive Loading Conditions

Output	Min	Max
+3.3V	10 μ F	12,000 μ F
+5V	10 μ F	12,000 μ F
+12V	10 μ F	11,000 μ F
-12V	1 μ F	350 μ F
+5Vsb	1 μ F	350 μ F

3.2.9 Close loop stability

The power supply shall be unconditionally stable under all line/load/transient load conditions including capacitive load ranges. A minimum of: 45 degrees phase margin and -12dB-gain margin is required.

Closed-loop stability must be ensured at the maximum and minimum loads as applicable.

3.2.10 Residual Voltage Immunity in Standby mode

The power supply should be immune to any residual voltage placed on its outputs (typically a leakage voltage through the system from standby output) up to 500mV. There shall be no additional heat generated nor stressing of any internal components with this voltage applied to any individual or all outputs simultaneously. It also should not trip the protection circuits during turn on/off.

The residual voltage at the power supply outputs for no load condition shall not exceed 100mV when AC voltage is applied.

3.2.11 Soft starting

The power supply shall contain control circuit which provides monotonic soft start for its outputs without overstress of the AC line or any power supply components at any specified AC line or load condition.

3.2.12 Hot Swap Requirements

Hot swapping a power supply is the process of inserting and extracting a power supply from an operating power system. During this process the output voltages shall remain within the limits with the capacitive load specified.

The hot swap test must be conducted when the system is operating under static, dynamic, and zero loading conditions. The power supply shall use a latching mechanism to prevent insertion and extraction of the power supply when the AC power cord is inserted into the power supply.

3.2.13 Load sharing control

The +12 V output shall have active load sharing. When operating at 50% of full load, the output current of any 1+1 power supplies shall be within (+/-10%). For example, if power supply #1 is operating at 20A, then all other power supplies within the system shall be operating between 18A to 22A (+/- 10% of 20A).

All current sharing functions shall be implemented internal to the power supply by making use of the SBus signal. The power distribution board (Housing Back Plane), must connect the SBus signals between the power supplies together.

The power supply shall be able to share with up to 1+N supply in parallel.

The failure of a power supply shall not affect the load sharing or output voltages of the other supplies still operating. The power supplies must be able to load share with 100mV of drop between different power supply's output.

If the load sharing is disabled by shorting the load share bus to ground, the power supply shall continue to operate within regulation limits for loads less than or equal to the rating of one power supply.

Table 18 - Load share bus output characteristics

Item	Description	Min	Nominal	Max	Units
$V_{share}; I_{out}=Max.$	Voltage of load share bus at specified max output current		8		V
$\Delta V_{share}/\Delta I_{out}$	Slope of load share bus voltage with changing load		$8/I_{outmax}$		V/A

3.3 Timing Requirements

These are the timing requirements for the power supply operation. The output voltages must rise from 10% to within regulation limits (T_{vout_rise}) within 5 to 70ms. For +5Vsb, it is allowed to rise from 1 to 25ms. All outputs must rise monotonically. Table below shows the timing requirements for the power supply being turned on and off via the AC input, with PSON held low and the PSON signal, with the AC input applied.

3.3.1 Output Voltage Timing

The timing of signals and outputs are specified in below Table 19 and illustrated in Figure 2.

Table 19 - Turn on/off timing

Turn on	Description	Min	Max	Units
T_{vout_rise}	Output voltage rise time for all main output	5*	70*	Msec
$T_{sb_on_delay}$	Delay from AC being applied to 12Vsb being within regulation		1500	msec
$T_{ac_on_delay}$	Delay from AC being applied to all output voltage being within regulation		2500	msec
T_{vout_holdup}	Time all main output 12VI voltages stay within regulation after loss of AC.	13		msec
T_{pwok_holdup}	Delay from loss of AC to de-assertion of PWOK	12		msec
$T_{pson_on_delay}$	Delay from PSON [#] active to output voltages within regulation limits	5	400	msec
T_{pson_pwok}	Delay from PSON [#] deactivate to PWOK being de-asserted.		50	msec
T_{pwok_on}	Delay from output voltage(12V) within regulation limits to PWOK asserted at turn on	100	500	msec
T_{pwok_off}	Delay from PWOK de-asserted to output voltages dropping out of regulation limits.	1		msec
T_{pwok_low}	Duration of PWOK being in the de-asserted state during an off/on cycle using AC or the PSON signal	100		msec
T_{sb_vout}	Delay from 12Vsb being in regulation to main output being in regulation at AC turn on.	50	1000	msec
T_{12Vsb_holdup}	Time the 12Vsb output voltage stays within regulation after loss of AC	70		msec

* T_{vout_rise} : The 12Vsb output rise time shall be 1ms to 25ms.

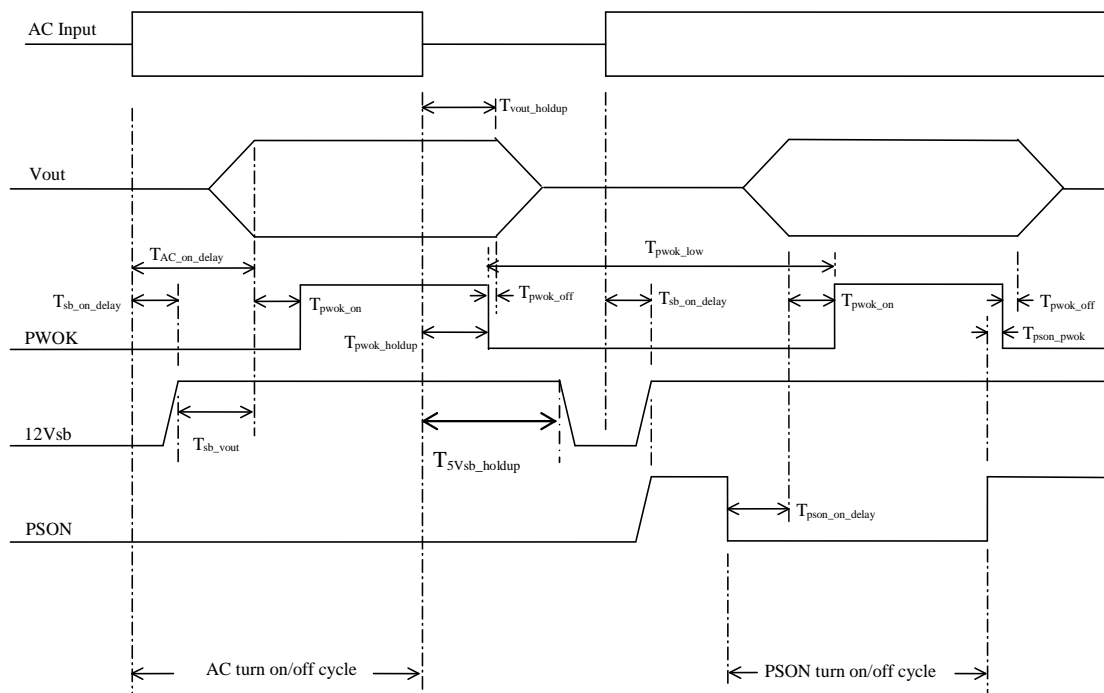

Figure 2 – Turn On/Off Timing (Power Supply Signals)

3.3.2 Overshoot

Any output overshoot at turn on shall be less than 10% of the nominal output value.

3.3.3 Undershoot

Any output shall not undershoot at turn on or off cycle under any circumstances.

3.3.4 Temperature coefficient

After operating for 30 minutes or longer at 25° C ambient, the output voltages shall not change by more than $\pm 0.05\%$ per degree C for any given line and load conditions.

3.4 Control and Indicator functions

The following section define the input and output signals from the power supply.

Signals that can be defined as low true use the following convention:

Signal[#] = low true.

3.4.1 PSON[#] Input Signal (Power supply enable)

The PSON[#] signal is required to remotely turn on/off the main output of the power supply.

PSON[#] is an active low signal that turns on the main output power rail. When this signal is not pulled low by the system or left open, the outputs (except the Standby output) turn off.

PSON[#] is pulled to a standby voltage by a pull-up resistor internal to the power supply.

See Table 20.

Table 20 – PS ON[#] signal characteristics

Signal Type	Accepts an open collector/drain input from the system. Pull-up to +3.3V located in the power supply.	
PSON [#] = Low	ON	
PSON [#] = High or Open	OFF	
	MIN	MAX
Logic level low (power supply ON)	0V	1.0V
Logic level high (power supply OFF)	2.0V	5.25V
Source current, V _{pson} = low		4mA
Power up delay: T _{pson_on_delay}	5ms	400ms
PWOK delay: T _{pson_pwok}		50ms

3.4.2 Power OK (PG or PWOK) Output Signal

PWOK is a power good signal and shall be pulled HIGH by the power supply to indicate that all outputs are within regulation limits. When any output voltage falls below regulation limits, a internal failure or when AC power has been removed for a time sufficiently long, so that power supply operation is no longer guaranteed, PWOK will be de-asserted to a LOW state. The start of the PWOK delay time shall inhibited as long as any power supply output is in current limit.

See Table 21.

Table 21 – PWOK signal characteristics

Signal Type	Open collector/drain output from power supply. Pull-up to +3.3V located in power supply.	
PWOK=High	Power Good	
PWOK=Low	Power Not Good	
	MIN	MAX
Logic level low voltage, I _{sink} =400μA	0V	0.4V
Logic level high voltage, I _{source} = 200μA	2.4V	5.25V
Sink current, PWOK=low		400μA
Source current, PWOK=high		2mA
PWOK delay: T _{pwok_on}	100ms	500ms
PWOK rise and fall time		100μs
Power down delay: T _{pwok_off}	1ms	200ms

3.4.3 SMBAlert[#] (PSAlert) Output Signal Pin

This signal indicates that the power supply is experiencing a problem that the user should investigate. This shall be asserted due to Critical events or Warning events. The signal shall activate in the case of critical component temperature reached a warning threshold, general failure, over-current, over-voltage, under-voltage, failed fan. This signal may also indicate the power supply is reaching its end of life or is operating in an environment exceeding the specified limits.

This signal is to be asserted in parallel with LED turning solid amber or blinking amber/green.

See Table 22.

Table 22 – SMBAlert[#] signal characteristics

Signal Type	Open collector/drain output from power supply. Pull-up to +3.3V located in power supply.	
Alert [#] =High	Power OK	
Alert [#] =Low	Power Alert to system	
	MIN	MAX
Logic level low voltage, $I_{\text{sink}}=4\text{mA}$	0V	0.4V
Logic level high voltage, $I_{\text{sink}} = 50\mu\text{A}$	2.4V	5.25V
Sink current, Alert [#] =low		4mA
Source current, Alert [#] =high		50 μA
Rise and fall time		100 μs

3.4.4 12V_{RS} and Return Sense

The power supply has remote sense return (Return Sense) to regulate out ground drops for all output voltages. The power supply uses remote sense to regulate out drops in the system for the main outputs. The +12V output only uses remote sense with reference to the Return Sense signal. The remote sense input impedance to the power supply must be greater than 10 Ω on the main outputs and is 10 Ω on Return Sense. These are the values of the resistors connecting the remote senses to the output voltage internal to the power supply. Remote sense is able to regulate out a minimum of 300mV of drop on the +12V output. The remote sense return is able to regulate out drops of 300mV as well. The current in any remote sense line shall be less than 5mA to prevent voltage sensing errors. The power supply operates within specification over the full range of voltage drops from the power supply's output connector to the remote sense points.

3.4.5 SDA and SCL

One pin is the serial clock (SCL), and the other pin is used for serial data (SDA). The SCL and SDA signals are pulled up by system, both pins are bi-directional, open drain signals, and are used to form a serial bus

4. Protection circuits

Protection circuits inside the power supply shall cause only the main output to shutdown (latch off). If the power supply latches off due to a protection circuit assert, an Input Power cycle OFF for 15sec or a PSON[#] cycle HIGH for 1sec shall be able to reset the power supply.

Specific protection circuits shall not latch, but auto recover when the latching reason had been cleared. This protection circuits will be written in cursive writing and will have a Auto Recover in the chapter name.

The auxiliary output shall not affected by any protection circuit, unless the auxiliary output itself is affected.

4.1 Over Voltage Protection (OVP_{main} & OVP_{auxiliary})

All Over Voltage Condition shall be measured internal to the power supply on all outputs (Main and Auxiliary Output) at the card edge output. The power supply shall shutdown and latch off after an Over Voltage condition occurs on main outputs, the auxiliary output shall be auto recover after the OVP had been removed.

The voltages never shall exceed the maximum levels specified in below table when measured during any fail.

Table 23 - Over Voltage Protection requirements

Output Voltage	MIN (V)	MAX (V)
+12 V	13.3	14.5
+5 V	5.7	6.5
+3.3 V	3.9	4.5
-12 V	-13.3	-14.5
+5Vsb	5.7	6.5

4.2 Over Current and Short Circuit Protection (OCP/SCP_{main} & OCP/SCP_{auxiliary})

The Over Current Condition shall be measured internal to the power supply on all outputs (Main and Auxiliary Output), and preventing outputs to exceed current limits specified in below table. The power supply shall shutdown and Auto Recovery after an over current condition on Main and Auxiliary Outputs, and shall be Auto Recovery when OCP/SCP condition is removed.

The power supply shall alert the system of the OCP/SCP condition via SMBAlert[#] and fail LED indicator.

The power supply shall not be damaged from repeated power cycling in this condition.

Table 24 – Over Current/Short Circuit Protection

Voltage	Over Current Limit (Iout limit)
+12 V	120% minimum; 150% maximum
+5 V	110% minimum; 150% maximum
+3.3 V	110% minimum; 150% maximum

4.3 Over Temperature Protection (OTP) of Module

The power supply shall have minimum of two thermal sensors to measure the inside environmental (T_{in_env}) and critical component ($T_{Heatsink}$) temperature. The thermal sensors shall be part of a protection circuit to protected against over temperature conditions caused by loss of fan cooling or excessive ambient temperature. In an critical Over temperature condition, specified in below table, the PSU shall be shutdown with the exception of the auxiliary output.

The power supply shall alert the system of the OTP condition via SMBAlert[#] and fail LED indicator. The power supply will auto recover from this condition, when the temperature is dropping within specification again. If the OTP is caused due to a defective fan, the power supply shall latch off and not auto recovery.

Table 25 – Over Temperature Protection of Module

Condition	Warning in °C	Critical in°C	Timing for SMBAlert [#] /LED
T_{in_env}	60	65	1msec
$T_{Heatsink}$	70	75	1msec

4.4 Fan Failure Protection of Module

The power supply shall have a circuit internal to monitor the power supply internal fan. The fan failure protection shall monitor the fan speed and should assert SMBAlert[#] and fail LED signal in case the fan Rotation Per Minute (RPM) drop lower threshold or set PWM Δ as defined in below table.

The fan failure state shall shut down and latch off the main outputs, and shall be cleared by toggling the PSON[#] signal or by an AC input recycle.

Table 26 – Fan Failure Protection of Module

Condition	FAN RPM	Timing for SMBAlert [#] /LED
Critical	1000	1sec

5. Power Supply Management

5.1 Hardware Layer

The serial bus communication devices for Power Supply Management Controller (PSMC) and Field Replacement Unit (FRU) in the power supply shall be compatible with both SMBus 2.0 “high power” and I²C Vdd based power and drive specification.

This bus shall operate at 3.3V but be tolerant to 5V pull-ups. The power supply should not have any internal pull-ups on the SMBus, pull-ups shall be located on system side.

Two pins are allocated on the power supply. One pin is the serial clock (SCL). The second pin is used for serial data (SDA). Both pins are bi-directional and are used to form a serial bus. The circuits inside the power supply shall derive their 3.3V power from the 5Vsb bus through a buffer. Device(s) shall be powered from the system side of the 5Vsb oring device. No pull-up resistors shall be on SCL or SDA inside the power supply. The pull-up resistors should be located external to the power supply on system/application side.

5.2 Power Supply Management Controller (PSMC)

The PSMC device in the power supply shall derive its power of the 5Vsb output on the system side of the oring device and shall be grounded to return. It shall be compatible with SMBus specification 2.0 and PMBus™ Power System Management Protocol Specification Part I and Part II in Revision 1.2.

Refer to the specification posted on www.ssiforum.org and www.pmbus.org website for details on the power supply monitoring interface requirements and refer to followed section of supported features.

5.2.1 Related Documents

- PMBus™ Power System Management Protocol Specification Part I – General Requirements, Transport And Electrical Interface; Revision 1.1 and 1.2
- PMBus™ Power System Management Protocol Specification Part II – Command Language; Revision 1.1 and 1.2
- System Management Bus (SMBUS) Specification 2.0

5.2.2 Data Speed

The PSMC device in the power supply shall operate at the full 100kbps (100kHz) SMBus speed and avoid using clock stretching that can slow down the bus. For example, the power supply is allowed to clock stretch while parsing a command or servicing multiple interrupts or NACK.

Unsupported commands may respond with a NACK but must always set the communication error status bit in STATUS_CML.

The PSMC may support 400kbps (400kHz) PMBus speed.

5.2.3 Bus Errors

The PSMC shall support SMBus clock-low timeout (T_{timeout}). This capability requires the PSMC to abort any transaction and drop off the bus if it detects the clock being held low for >25ms, and be able to respond to new transactions within 10ms later. The total reset time from detection of the condition till restarted, ready to receive commands condition shall not exceed 35ms.

The device must recognize SMBus START and STOP conditions on ANY clock interval. The PSMC must not hang due to ‘runt clocks’, ‘runt data’, or other out-of-spec bus timing. This is defined as signals, logic-level glitches, setup. Or hold times that are shorter than the minimums specified by the SMBus specifications. The PSMC is not required to operate normally, but must return to normal operation once ‘in spec’ clock and data timing is again received. Note if the PSMC ‘misses’ a clock from the master due to noise or other bus errors, the device must continue to accept ‘in spec’ clocks and NACK. The PSMC is suppose to re-synch with the master on the next START or STOP condition.

5.2.4 Write byte/word

The first byte of a Write Byte/Word access is the command code. The next one or two bytes, respectively, are the data to be written. In this example the master asserts the slave device address followed by the write bit. The device acknowledges and the master delivers the command code. The slave again acknowledges before the master sends the data byte or word (low byte first). The slave acknowledges each byte, and the entire transaction is finished with a STOP condition.

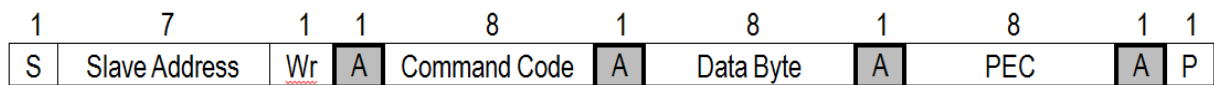

Figure 3 –Write byte protocol with PEC

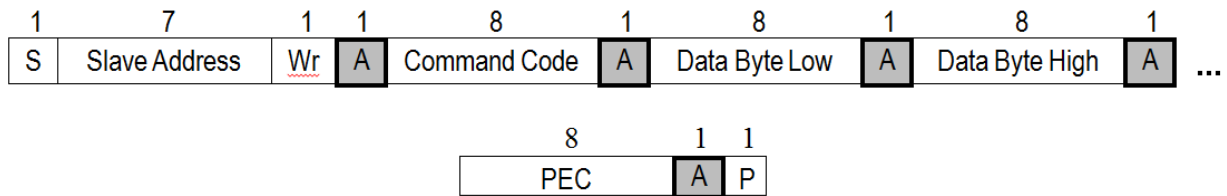

Figure 4 –Write Word Protocol with PEC

5.2.5 Read byte/word

Reading data is slightly more complicated than writing data. First the host must write a command to the slave device. Then it must follow that command with a repeated START condition to denote a read from that device’s address. The slave then returns one or two bytes of data.

Note that there is no STOP condition before the repeated START condition, and that a NACK signifies the end of the read transfer.

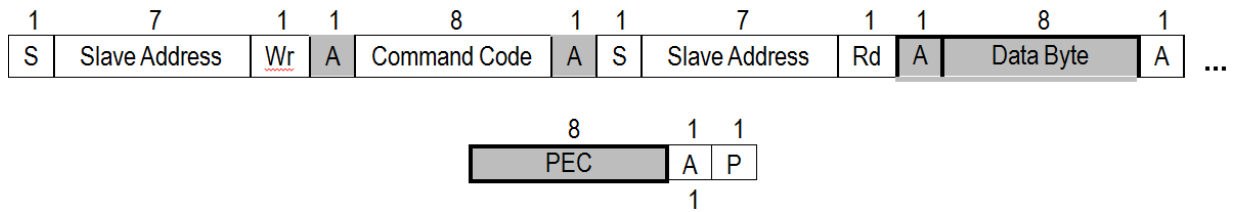

Figure 5 –Read byte protocol with PEC

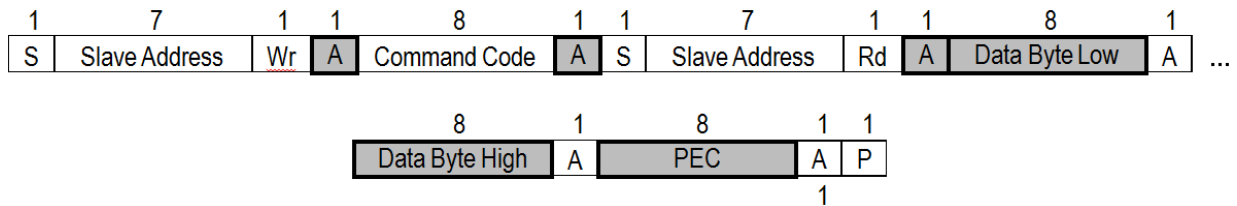

Figure 6–Read word protocol with PEC

5.2.6 Block write/read

The Block Write begins with a slave address and a write condition. After the command code the host issues a byte count which describes how many more bytes will follow in the message. If a slave has 20 bytes to send, the byte count field will have the value 20 (14h), followed by the 20 bytes of data. The byte count does not include the PEC byte. The byte count may not be 0. A Block Read or Write is allowed to transfer a maximum of 32 data bytes.

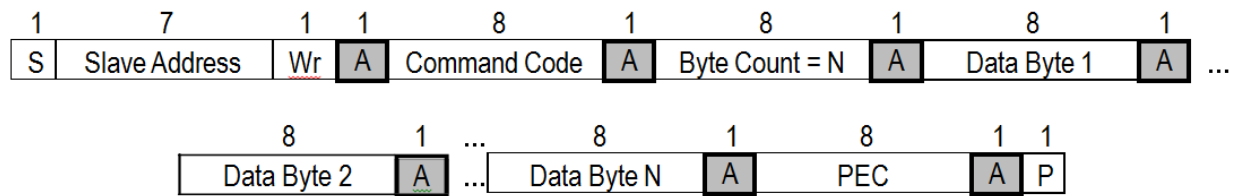

Figure 7 –Block Write with PEC

A Block Read differs from a block write in that the repeated START condition exists to satisfy the requirement for a change in the transfer direction. A NACK immediately preceding the STOP condition signifies the end of the read transfer.

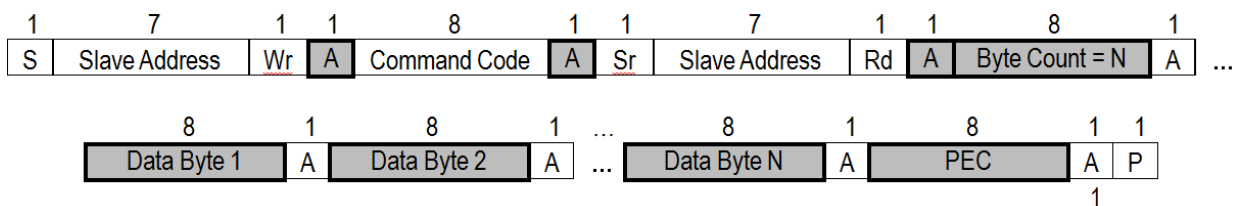

Figure 8 –Block Read with PEC

5.2.7 Sensor Accuracy

The sensor of the PSMC shall meet below accuracy requirements for sensor readings. The accuracy shall be meet at the specified environmental condition and the full range of rated input voltage.

- READ_VIN
- READ_IIN
- READ_VOUT
- READ_IOUT
- READ_PIN
- READ_POUT

Table 27 – Sensor Accuracy of Housing

	Required Accuracy (+/-x% of equipment reading)(Vin range=100v-240v)		
Sensor	< 10% load	10% - 20% load	> 20% - 100% load
Pout	± 10W	± 10W	± 5%
Vout	± 5%		
Iout	NA	± 10%	± 5%

Table 28 – Sensor Accuracy of Module

	Required Accuracy (+/-x% of equipment reading)(Vin range=100v-240v)		
Sensor	< 10% load	10% - 20% load	> 20% - 100% load
Pin	± 10W	± 10W	± 5%
Pout	± 10W	± 10W	± 5%
Vin	± 5%		
Vout	± 5%		
Iin	NA	± 15%	± 5%
Iout	NA	± 10%	± 5%

5.2.8 PSMC Sensors

Sensors shall be available to the PSMC for monitoring purpose.

All Sensors shall continue to provide real time data as long as the PSMC device is powered.

This means in standby and operation mode, while in standby the main output(s) of the power supply shall read zero Amps and Volts.

Table 29 – PSMC Sensor list

Sensor	Description
V_{input}	Input Voltage
I_{input}	Input Current
P_{input}	Input Power
V_{output_main}	Output Voltage main output
I_{output_main}	Output Current main output
P_{output_main}	Output Power main output
V_{output_aux}	Output Voltage auxiliary output
I_{output_aux}	Output Current auxiliary output
P_{output_aux}	Output Power auxiliary output
T_{comp}	Component Temperature
T_{env}	Environmental Temperature
RPM_{Fan}	Fan Speed reading

5.3 Power Supply Field Replacement Unit (FRU)

The power supply shall support electronic access of FRU information over an I²C bus. Two pins will be allocated for the FRU information on the Power Supply connector. They are named SCL, SDA. SCL is serial clock. SDA is serial data. These two bidirectional signals from the basic communication lines over the I²C bus. The backplane defines the state of these lines such that the address to the power supply is unique within the system. The resulting I²C address shall be per table below. The Write protection pin is to ensure that data will not accidentally overwritten.

The device used for this shall be powered from a 3.3V bias voltage derived from the +12 Vsb output . The pull-up resistors shall be on SCL or SDA inside the power supply.

Table 30 - FRU Signals

	MCU Address	
	PMBus	IPMI FRU
PSU - 1	B0	A0
PSU - 2	B2	A2
Housing	4A	AC

5.3.1 FRU Data

The FRU Data format shall be compliant with the IPMI ver. 1.0 (per rev. 1.1 from Sep.25th, 1999) specification. The current version of these specification is available at <http://developer.intel.com/design/servers/ipmi/specs.htm>. The following is the exact listing of the EEPROM content. During testing this should be followed and verified.

5.3.2 FRU Device protocol

The FRU device will implement the same protocols as the commonly used memory device, including Byte Read, Sequential Read, Byte Write, and Page Read protocols.

6. Smart On Function

6.1 PMBus command for Smart On

6.1.1 Hardware Connection

Before enabling Smart On function, make sure pin B22 (SMART ON) on output golden finger of each PSU is connected together.

6.1.2 Configuring Smart On with SMART_ON_CONFIG (D0h)

The PMBus manufacturer specific command MFR_SPECIFIC_00 is used to configure the operating state of the power supply related to Smart On. We will call the command SMART_ON_CONFIG (D0h). Below is the definition of the values used with the Read-Write Byte SMBus protocol with PEC.

SMART_ON_CONFIG (D0h)		
Value	State	Description
00h	Standard Redundancy	Turns the power supply ON into standard redundant load sharing mode.
01h	Smart On Active	Defines this power supply to be the one that is always ON in a Smart On configuration.
02h	Smart Standby	Defines the power supply that to turn off (load<36%) in a Smart On configuration and first to turn on (load>40%) as the load increases.

The default state of power supply is in Standard Redundancy mode. Power supply need to be re-specified a state whenever initial power on or any power supply in the system is in fault situation.

The SMART_ON_CONFIG command will reset to 00h (Standard Redundancy) when any fault or over current happened. The faults include AC loss, over hot spot temperature, over ambient temperature, +12V short internally (under voltage), +12V over voltage, fan locked, D2D controller soft-start short.

6.2 Smart Standby Power Supply Operating State

A power supply is put into Smart Standby whenever PSON# is asserted, and SMART_ON_CONFIG value is set to 02h.

In the Smart Standby mode the power supply must:

1. Power ON when Smart_On bus is driven LOW
2. Keep PWOK asserted
3. No PMBus fault or warning conditions reported via STATUS commands
4. Keep all fans rolling
5. LED is green blinking

6.2.1 Powering on Smart Standby supplies to maintain best efficiency

Power supplies in Smart Standby state shall monitor the shared voltage level of the load share signal to sense when it needs to power on. Depending upon which position the system defines that power supply to be in the Smart Standby configuration; will slightly change the load share threshold that the power supply shall power on at.

6.2.2 Powering on Smart Standby supplies during a fault or over current condition

Some warnings happen or 12V output shutdown due to any fault. When an active power supply asserts, all parallel power supplies in Smart Standby mode shall power on immediately.

The trigger condition:

1. 12V OC fault happens
2. 12V OVP fault
3. 12V UVP fault
4. OTP warning/ fault
5. Fan speed fault
- 6.AC loss(low than 75V +/-5V)

When an active power supply asserts, all parallel power supplies in Smart Standby mode shall power on immediately.

6.3 The Way to Enable Smart On Function

Here are the steps to put PSU into smart on mode. PSU which is assigned as smart on standby can operate in a power-off state and turn on main power if necessary.

The trigger levels above may have a +/-10% tolerance for actual application.

Step1: Make sure every PSU has AC power cord applied. Use write byte command to set command 0xD0 for each PSU to has it own role (must one PSU as active role).

The command format for Smart On function will be as following example.

B0 in smart_on_active (S B0 w D0 01 PEC P)

B2 in smart_on_standby (S B2 w D0 02 PEC P)

Step2: PSU will enter smart slave mode once the load is lower than the corresponding trigger point.

Step3: If SMART_ON signal falls to low, all PSU will turn on the main power and reset smart_config to 0x00 (standard redundancy). System needs to re-assign the roles for all PSU to enable smart on function again.

7. ENVIRONMENTAL

The power supply shall operate normally, and sustain no damage as a result of the environmental conditions listed in this chapter.

7.1 Temperature

Operating Ambient, normal mode (inlet Air): 0°C min/+50°C max at 5000m above sea level.

(At full load, with a maximum rate of change of 5°C/10 minutes, but no more than 10°C/hr)

Operating Ambient, stand-by mode (inlet Air): -5°C min/+50°C max at 5000m above sea level.

Non-operating ambient: -40°C to +70°C (Maximum rate of change shall be 20°C/hr)

7.2 Humidity

Operating: 5% - 90% relative humidity (non-condensing)

Non-operating: 5% - 95% relative humidity (non-condensing)

Note: 95% relative humidity is achieved with a dry bulb temperature of 55°C and a wet bulb temperature of 54°C.

7.3 Altitude

A) Operation : sea level to 5000m

B) Non-Operation : sea level to 15,200m

7.4 Vibration

A) Operation : 0.01g²/Hz at 5 Hz sloping to 0.02g²/Hz at 20 Hz, and maintaining 0.02g²/Hz from 20 Hz to 500 Hz. The area under the PSD curve is 3.13gRMS. The duration shall be 20 minutes per axis for all three axes on all samples.

B) Non-Operation :

- **Sine sweep:** 5Hz to 500Hz @ 0.5gRMS at 0.5 octave/min; dwell 15min at each of 3 resonant points;

7.5 Mechanical Shock

A) Operation: 10G, 4.3 mSec, no malfunction

B) Non operating: 50G Trapezoidal Wave, Velocity change = 4.3m/sec. Three drops in each of six directions are applied to each of the samples.

7.6 Thermal shock (Shipping)

Non-operating: -40°C to +70°C, 50 cycles, 30°C/min. \geq transition time \geq 15°C/min., duration of exposure to temperature extremes for each half cycle shall be 30minutes.

7.7 Catastrophic Failure

The power supply shall be designed to fail without startling noise or excessive smoke.

7.8 EMI

The power supply shall comply with FCC part 15, CRISP 22 and EN55-22; Class B for both conducted and radiated emissions with a 3dB margin. Test shall be conducted using a shielded DC output cable to a shielded load. The load shall be adjusted to 100% load. Test will be performed at 115VAC @ 60Hz and 230VAC @ 50Hz power.

The power supply shall comply with EN55024.

The power supply when installed in the system must meet the following all the immunity requirements when integrated into the end system.

7.9 Magnetic Leakage Fields

The PFC choke magnetic leakage field shall not cause any interference with a high resolution computer monitor placed next to or on top of the chassis.

7.10 Voltage Fluctuations and Flicker

The power supply shall meet the specified limits of EN61000-3-3, for voltage fluctuations and flicker for equipment \leq 16 amps connected to low voltage distribution systems.

8. REGULATORY Requirements

Intended Application – This product was evaluated as Information Technology Equipment (ITE), which may be installed in offices, schools, computer rooms, and similar commercial type locations. The suitability of this product for other product categories and environments (such as: medical, industrial, telecommunications, NEBS, residential, alarm systems, test equipment, etc.) other than ITE application, may require further evaluation.

8.1 Product Safety Compliance

- A) UL 60950-1/CSA 60950-1 Edition 2 (USA/Canada)
- B) EN60950-1 Edition 2 (Europe)
- C) IEC60950-1 Edition 2 (International)
- D) CB Certificate & Report, IEC60950-1 Edition 2 (report to include all country national deviations)
- E) CE – Low Voltage Directive 2006/95/EC (Europe)
- F) GB4943-CBCA Certification (China)

8.2 Product EMC Compliance – Class B Compliance

Note: The product is required to comply with Class B emission, as the system it is build into might be configured with the intend for commercial environment or home use. The Power supply is to have a minimum of 3dB margin to Class B Limits to support FSP's Standard margin requirements.

- A) FCC / ICES-003 Emission (USA/Canada) Verification
- B) CRISP 22 – Emission (International)
- C) EN55022 – Emission (Europe)
- D) EN55024 – Immunity (Europe)
 - EN61000-4-2 Electrostatic Discharge
 - EN61000-4-3 Radiated RFI Immunity
 - EN61000-4-4 Electrical Fast Transients
 - EN61000-4-5 Electrical Surge
 - EN61000-4-6 RF Conducted
 - EN61000-4-8 Power Frequency Magnetic Fields
 - EN61000-4-11 Voltage Dips and Interruptions

- E) EN61000-3-2 – Harmonics (Europe)
- F) EN61000-3-3 – Voltage Flicker (Europe)
- G) CE – EMC Directive 2004/108/EEC (Europe)
- H) JEIDA (Japan)
- I) AS/NZS CISPR 22 (Australia / New Zealand)
- J) GB 9254 2008 (EMC) Certification (China)
- K) GB 17625.1 – (Harmonics) CNCA Certification (China)

8.3 Maximum AC Leakage current to ground

1.0mA max for each power supply at 264Vac/60Hz.

8.3.1 Hi-pot

The power supply module in the system shall be test at 1800Vac, with a trigger limit of 30mA.

8.4 Electrostatic Discharge (ESD)

In addition to IEC 801-2/ IEC1000-4-2, the following ESD tests shall be conducted. Each surface area of the system under test shall be subjected to twenty (20) successive static discharges, at each of the following voltages: 15kV.

Performance criteria:

- A) All power system output shall continue to operate within the limits of this specification, without glitches or interruption, while the supply is operated as defined and subjected to 2kV through 15kV ESD pulses. The direct ESD event shall not cause any out of regulation condition. The power system shall withstand these tests without nuisance trips.
- B) The power system, while operating as defined, shall not have a component failure when subjected to any discharge voltages up to and including 15kV. Component failure is defined as any malfunction of the power supply caused by component degradation or failure requiring component replacement to correct the problem.

8.5 Certifications / Registrations/ Declerations

- A) UL Certification (US)
- B) CB Certification & Report
- C) TÜV Rheinland (Germany)
- D) CE Declaration of Conformity (CENELEC Europe)
- E) CCC / CNCA Certification (China)

8.6 Component Regulation Requirements

1. All Fans shall have the minimum certifications: UL and TÜV or VDE
2. All current limiting devices shall have UL and TÜV or VDE certifications and shall be suitable rated for the application where the device In its application complies with IEC60950.
3. All printed wiring boards shall be rated UL94V-0 and be sourced from a UL approved printing wiring board manufacturer.
4. All connectors shall be UL recognized and have a UL flame rating of UL94V-0
5. All wiring harnesses shall be sourced from a UL approved wiring harness manufacturer.

SELV cable to be rated minimum 80V @ 120°C
6. Product safety label must be printed on UL approved label stock and printer ribbon.

Alternatively labels can be purchased from a UL approved label manufacturer.
7. The product must be marked with the correct regulatory markings to support the certifications that are specified in this document.

8.6.1 Product Ecology Requirement

All materials, parts and subassemblies must not contain restricted materials as defined in directive 2002/95/EC, Restriction of Hazardous Substances (RoHS) 6/6.

All cords and cables shall contain <100ppm of cadmium.

All packing materials must be marked with applicable recycling logos for Europe (green dot) and Japan (Eco-marks), if sold as a retail product. All packing materials shall be recyclable.

9. Reliability / Warranty / Service

9.1 Mean Time between Failures (MTBF)

The power supply shall have a minimum MTBF at continuous operation of 200,000 hours calculated at 100%, according to BELL CORE TR-322 at 25°C excluding the Fan MTBF, and at least 100,000 hours including the fan MTBF.

9.2 Warranty

The Warranty for the power supply is 36 months (three years) from production date code.

9.3 Serviceability

No troubleshooting by maintenance personnel is to be performed. Units shall be returned to FSP Power for any troubleshooting, unless agreed by both parties.

The power supply will lose warranty if opened other than FSP service personal or agreed by both parties.